



THE NEFF COLLECTION

NEFF 80cm Vented Flex Induction Cooktop

2 in 1: A cooktop and rangehood in one appliance



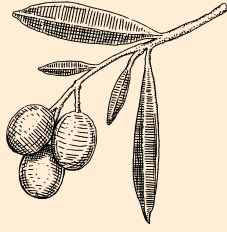

For some, it's a cooktop that also ventilates perfectly. For others, it's a hood that also cooks perfectly. You now have the perfect solution for an island bench setting without the obstruction of an overhead rangehood. The NEFF vented cooktop will allow you to design your kitchen with no limitations, giving you the ability to create a true open plan kitchen and living area to enjoy every day.



An 80cm cooktop with integrated ventilation



KITCHEN PLANNING

**All the headroom you need.
All the planning freedom you want.**

Installed in an island bench, the vented cooktop removes the need for an overhead rangehood, keeping the space clear and giving you an unobstructed view while cooking. Downdraft ventilation also allows for the cooktop to be installed in other non-traditional areas, such as under a window or slanted ceiling.



AT A GLANCE:

- Two units in one: cooktop and rangehood.
- The perfect solution for an open plan, working island kitchen.
- Ventilation noise is no longer at ear level; enjoy your kitchen conversations without the frustration of an overhead rangehood.
- Ample space for cupboards or drawers below.

The best features of our NEFF Vented Cooktop

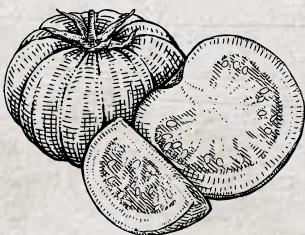

COMBINE ALL THE FEATURES OF A NEFF FLEXINDUCTION COOKTOP WITH NEW INNOVATIONS IN VENTILATION TECHNOLOGY.

The Vented FlexInduction cooktop retains features that make NEFF a favourite among serious cooks - like the TwistPadFire® and flexible zones - while integrating ventilation that is both quiet and powerful.



MAGNETIC CONTROL DIAL

Where surface grease and oil can make touch controls frustratingly unresponsive, the TwistPadFire® control dial makes it easy. Just place the magnetic dial in the control area and press toward the zone you want to adjust. When it's time to give the surface a clean, simply lift it away!



AUTOMATIC AIR SENSOR

Monitors steam and odours and adjusts the ventilation power level automatically.



EASY TO CLEAN

Simply pull the grease filter out, pop it into your dishwasher and let it take care of the dirty business.

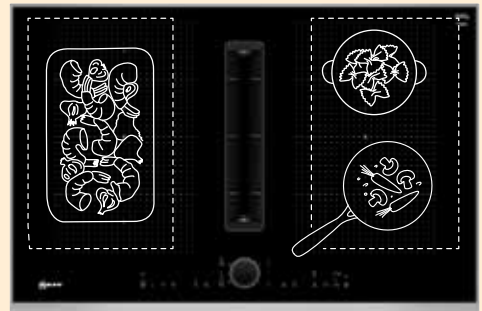

DOUBLE FLEX INDUCTION

Move your pots and pans anywhere within the FlexInduction zone. Their size and shape are automatically detected and heat is applied at their exact location.

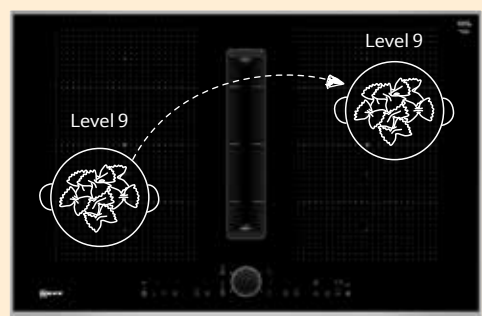

POWER TRANSFER

Move pots anywhere in the double FlexZone and the setting will automatically move with them.



POWER MOVE

Divide the cooktop into three heat zones, each with a different power level, so you can easily move a pot between intense heat at the front, simmering in the middle and a low, keep-warm temperature at the back.



HOME CONNECT

Adjust the extraction level from the comfort of your sofa or browse a world of inspiring recipes. With the Home Connect App, the future of cooking is at your fingertips.

Wall or island design?

Ducted or recirculated extraction configuration?

The NEFF vented cooktop knows no limits. Whether it's a functional, space-saving wall planning or an open-plan living concept with an island design, the possibilities are endless – the vented cooktop always fits in seamlessly.



All vented cooktop variants can be planned with both ducted and recirculation extraction configurations. This means that classic kitchen planning as well as progressive design-driven concepts – including floating islands installed entirely without air ducts – can be easily realised.



In a recirculation configuration, the cooking steam is additionally filtered through powerful and durable active carbon filters that eliminate odours, and are comfortably and conveniently accessible from the top of the appliance. Because of their integration into the appliance itself, the recirculation filters don't need to be installed in less accessible areas like the flat duct system or behind the drawers in the base cabinet area – which further facilitates planning and expands the design options. Recirculation configurations are possible as unducted, partly ducted, or fully ducted configurations to meet any design requirements or preferences.



In a ducted extraction configuration, a standard flat duct system discharges the cooking steams and vapours through an opening in the wall to eliminate cooking odours.

Induction Cooktop with Downdraft Ventilation

FlexInduction

T58TL6EN2 | 80cm

**Induction Cooktop with
Downdraft Ventilation**

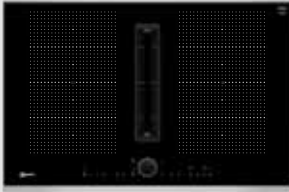

FlexInduction

TwistPad Fire®

PowerMove

PowerTransfer

FryingSensor

Power Boost

PotBoost

PanBoost

KeepWarm

Residual Heat Indicator

Wipe Protection

Auto Pan Recognition

Automatic Shut Off

Child safety lock

**LED display and timer
for each zone**

Cooking zones:

4 induction zones
including 2 FlexInduction zones

17 power levels per zone

Black ceramic glass with stainless
steel flush-fitted trim

EfficientDrive Brushless motor

Saturation Indicator

Automatic Air Sensor

Home Connect

Special Features:

Automatic air sensor monitors
steam and odours and adjusts the
power level automatically, or can
be manually controlled via the
TwistPadFire®

Slim, flush air inlet for barrier-free
cookware movement

Dishwasher safe stainless steel
grease filters

Bonus installation accessory for
unducted recirculation extraction
and ducted extraction included

Ventilation information:

17 fan speed levels
plus 2 intensive settings

Maximum extraction rate
622m³/h

42/69dB (min/max)
normal level

Dimensions (HxWxD)

223 x 826 x 546mm



Induction Accessories

NEFF has optional accessories suitable for induction cooktops. They are designed to offer you greater flexibility and technique.



Z9416X2

GRIDDLE PLATE

Versatile griddle plate **Z9416X2** for cooking food evenly and quickly. Easy to clean.

Cooking area: 37 x 25cm.



Z9417X2

TEPPAN YAKI PLATE

The Teppan Yaki plate **Z9417X2** introduces a new cooking style for creating special dishes including sweet couscous cookies, parmesan French toast and skewers of minced meat. It is highly controllable and flexible via multiple heat zones that enable you to cook and warm several dishes at once.

Cooking area: 38 x 21cm.



Z943SE0

3-PIECE INDUCTION COOKWARE SET

3 piece induction cookware set **Z943SE0** consists of 2 pots with glass lids (Ø 18cm; 3.6 litre capacity and Ø 14cm; 1.9 litre capacity) and 1 Frying pan with non-stick coating (Ø 22cm).



Z9406SE0

6-PIECE PRO INDUCTION COOKWARE SET

6 piece ProInduction Cookware Set

Consists of:

- 1 x Ø 22cm Pot with Glass Lid
- 1 x Ø 18cm Pot with Glass Lid
- 1 x Ø 14cm Pot with Glass Lid
- 1 x Ø 22cm Pan with non-stick coating
- 1 x Ø 18cm Pan with non-stick coating
- 1 x Ø 14cm Saucepan



Z9428FE0

PRO INDUCTION PAN

ProInduction Pan

Ø28cm, non-stick coating.

(suitable for all electric cooktops including induction)

Available September 2022



Z9453X0

FRYING PAN

The Frying Pan **Z9453X0** is ideal for NEFF induction cooktops with FryingSensor and allows you to hold a selected temperature constantly – no further adjustments required.

Size: Ø 21cm.

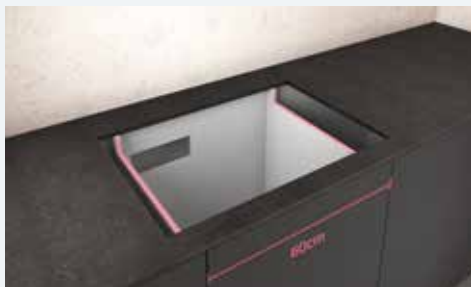

The side panels of the base cabinet can be extended with cabinetry adjustment to fit a wider cooktop. Only the centralised ventilation base immerses with the full depth. The depth should be considered when planning respective drawers. **It is recommended to not plan additional built-in appliances below the unit.**



The distance between base cabinets and wall units can be chosen freely.

There are no appliance related requirements – except the easy handling of cookware.

A WIDE-RANGE OF INSTALLATION ACCESSORY OPTIONS ALLOW FOR EVERY MARKET-STANDARD CONFIGURATION

The appliance is equipped with the accessories for the most common type of installation: unducted recirculation. For other types of installation, the following accessory kits can be ordered separately.

OPTION 1: UNDUCTED RECIRCULATION



Replenishment CleanAir odour filters can be ordered by calling the NEFF customer service team on 1300 087 033 using part number: 17004806 (set of four)

INCLUDED WITH COOKTOP

4 x

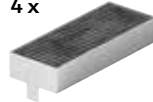

Includes 'Plug&Play' accessory for unducted recirculation extraction in an island bench or against an internal wall. This installation kit for ductless recirculation extraction inside the kitchen, such as an island bench setting, enables very convenient planning and quick installation. It includes:

- 4 high-performance CleanAir odour filters with optimised odour reduction performance for cooking applications with complex odour molecules (e.g. fish). Large scale filter surfaces with high odour reduction capabilities and a lifetime of 360 hours of cooking (non-regenerative). Filters are additionally optimised for low-noise with specially designed psycho-acoustics.
- A telescopic slider element with a self-gluing fixation frame to easily connect the appliance's air outlet with the cut-out in back panel of the cabinetry.
- A sealing gasket to ensure air tightness, which can be attached on the telescopic slider or a male flat duct.

To ensure adequate air flow, a vent in the kickplate greater than 400cm² should be made (return-flow aperture of $\geq 400\text{cm}^2$). For ideal ventilation in this configuration, it is recommended to have a vertical aperture of 50mm behind the back panel of the cabinetry, with a minimum of 25mm required.

No additional ducting elements required. When planning a recirculated extraction scenario against an external wall, it is recommended to opt for a partly or fully ducted recirculation planning.

OPTION 2: DUCTED EXHAUST EXTRACTION



Z861KE1

4 x



Starter set of ducting elements for ducted exhaust extraction. Includes:

- 4 high-performance, low-noise acoustic filters for significantly lower noise and strongly improved psycho-acoustics.
- Vertical 90° 'S' bow flat duct element (male). Suitable for worktop depths from 60cm.
- Connector sleeve (female) to combine male flat duct elements.
- Straight tube element (male, 500mm).

Further ducting elements must be ordered additionally, according to the customized planning.

Please call the customer service team on 1300 087 033 to order additional flat duct elements.

OPTION 3: DUCTED RECIRCULATION

RECIRCULATION PARTLY DUCTED



Z861KR0 FOR WORKTOP DEPTHS ≥ 70 CM

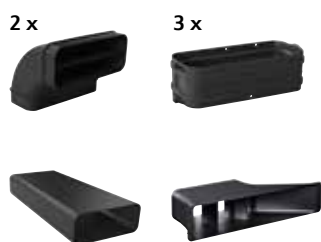

Set of ducting elements for partly ducted recirculation extraction. For partly or fully ducted recirculation extraction against an external wall we recommend the use of this basic kit.

Includes:

- 2x Vertical 90° 'L' bow flat duct element (male). Suitable for worktop depths ≥ 70 cm.
- 3x Connector sleeve (female) to combine male flat duct elements.
- Straight tube element (male, 500mm).
- Diffusor element that can be directly connected to the flat duct elements and that spreads the outflowing air in the plinth area for partly ducted recirculation configurations.

The elements enable installations in worktop heights up to 960mm. To ensure adequate air flow, a vent in the kickplate greater than 400cm² should be made (return-flow aperture of ≥ 400 cm²).

RECIRCULATION FULLY DUCTED



Z861KR0 FOR WORKTOP DEPTHS > 70 CM



For fully ducted recirculation, the above kit (Z861KR0) can be used as a starter kit. A straight tube and an additional connector sleeve are required to reach the kickplate.

For best results, the diffusor can be directly connected to the kickplate vent with adhesive tape.

Plus Additional straight tube (either 500mm or 1000mm depending on benchtop depth)

Plus additional connector sleeve.

Part numbers

1000mm tube: 17005033
500mm tube: 17005032
Sleeve: 17005040

INDIVIDUAL CONFIGURATION



Flat-duct accessory elements can be ordered individually by calling the NEFF customer service team on 1300 087 033, enabling customised planning. To view all available ducting elements, visit neff.com.au/service/accessories/ducting#tab-navigation

Installation options

Planning to install your venting cooktop in recirculation mode against an exterior or interior wall?



When installed against an exterior/outside wall, a partly or fully ducted recirculation configuration is recommended. Unducted recirculation extraction is not recommended against an outside wall due to potential condensation risk.

Exception: Only if the exterior wall is very well insulated ($\mu < 0.5 \text{ W/m}^2\text{C}$) would an unducted recirculation installation would be possible.



Next to interior walls and for island designs, all recirculating configurations are possible.

When installed in an island bench or against an interior wall, unducted recirculation configuration is recommended.



Scan the QR code to watch the video of the various installation options.*



*The video is intended for professional installers use only.

Flat-duct accessory elements from NEFF.

The new NEFF flat duct system offers a maximum of flow-rates and flexibility combined with a fantastic ease of installation, even in complex situations.

The simple basic principle: 'Male' parts can be easily and airtightly connected by a two-part, clip-on, 'female' connector sleeve element. The integrated seal eliminates the need for the usual adhesive (duct) tapes. The connector sleeves give the system a clear advantage – even in complex situations – to easily and quickly connect duct elements. Straight elements are easy to cut to size.

The system's elements are designed and optimised for ducting combined with all offered NEFF ventilation solutions. Aerodynamic optimisation ensures the highest flow rates and ideal appliance performance even with longer ducting.

The materials used in all ducting elements offer the utmost safety and comply with the highest standards: The Needle Flame Test (according to IEC 60695-5-11) and the B1/B2 building material class (according to DIN 4102-1). All elements offer standard outer geometries of 220 x 90mm with an (outer) corner radius of 20mm.



Flat-duct accessory elements

from NEFF

17005040



Connector sleeve (female) to combine male flat duct elements.

17005032



Straight tube element (male, 500mm).

17005033



Straight tube element (male, 1000mm).

17005360



Male adaptor element to combine round and flat duct elements.

17005362



Male 90° adaptor element to combine round and flat duct elements.

17005356



Horizontal 90° bow flat duct element (male).

11037001



Diffuser element for partly or fully ducted recirculation.

17006154



Flexible, female sleeve element to combine male flat duct elements.



All elements are having a (outer) corner radius of 20mm.

17006153

Vertical 90° 'S' bow flat duct element (male).

Suitable for worktop depths ≥ 60 cm.

17005037

Vertical 90° 'M' bow flat duct element (male).

Suitable for worktop depths ≥ 65 cm.

17005034

Vertical 90° 'L' bow flat duct element (male).

Suitable for worktop depths ≥ 70 cm.

**Z861SB4**

The vertical 90° 'S' bow with a tight radius enables ducting within the cabinetry and offers (with respect to the positioning of the worktop) a minimum space of 44mm for the base unit's drawers.

**Z861SB3**

The vertical 90° 'M' bow with a medium radius enables ducting (partly) within the cabinetry and offers (with respect to the positioning of the worktop) a minimum space of 475mm for the base unit's drawers.

**Z861SB2**

The vertical 90° 'L' bow with a large radius enables ducting behind the backpanel of the cabinetry and offers (with respect to the positioning of the worktop) maximum space for full drawer depths in the base unit.

All elements are having a (outer) corner radius of 20mm.

Notes on drawer and countertop depths

The possible drawer depth and the required worktop depth depend on the selected ducting configuration, and - depending on the planning scenario - the vertical 90° flat duct bow element used.

Installation scenarios in unducted recirculation configurations offer the most convenient planning options.

With its flexible, telescopic part, the installation accessory connects the appliance's air outlet to the back wall panel of the cabinetry. Since no other ducting elements are necessary, planning is possible with full drawer depths and worktop depths from 60cm.

Planning scenarios with ducted configurations do need vertical 90° flat duct bow elements. These elements do offer different characteristics with respect to the bow element chosen.



Exterior wall planning and installations in recirculation configurations



The vertical 90° 'S' bow with a tight radius enables ducting* within the cabinetry and offers (with respect to the positioning of the worktop) a minimum space of 448mm for the base unit's drawers.

This enables worktop depths ≥ 60 cm.

The 'S' bow is part of the accessory kit Z861KR1.



The vertical 90° 'M' bow with a medium radius enables ducting* (partly) within the cabinetry and offers (with respect to the positioning of the worktop) a minimum space of 475mm for the base unit's drawers.

This enables worktop depths ≥ 65 cm.



The vertical 90° 'L' bow with a large radius enables ducting* behind backpanel of the cabinetry and offers (with respect to the positioning of the worktop) maximum space for full drawer depths in the base unit.

This enables worktop depths ≥ 70 cm.

The 'L' bow is part of the accessory kit Z861KR0.

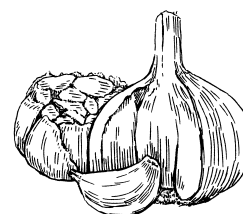

*The characteristics are applicable for all configurations with ducted air: partly or fully ducted recirculation and (fully) ducted extraction plannings.

Notes on immersion depths and kitchen matrix systems

6-DRAW KITCHEN MATRIX SYSTEM



5-DRAW KITCHEN MATRIX SYSTEM



The immersion depth is 223mm for top-mounted installations and 227mm for flush-mounted installations. Generally, all standard kitchen matrix systems and dimensions are possible. The installation depth required by the vented cooktop means that it only blocks the storage space in the top drawer.



In case the immersion depth exceeds the intended dimensions of the top fixed panel, planning is still possible if the second drawer's frames and side panels, and its contents, carry less height than the front panel itself. Although the vented cooktop then extends partway into this area, it doesn't interfere with the drawer's free movement.



If the front panel is the same height as the drawer frames and content, it may not be possible to use the second drawer.

Notes on worktop thickness

$\leq 16\text{mm}$

If the countertop is thinner than 16mm, the vented cooktop can still be easily installed. Simply ensure that an installation depth $\geq 16\text{mm}$ is achieved in the installation area – for example, by doubling the material.



$\geq 16\text{mm}$

Installation of the vented cooktop requires an installation thickness $\geq 16\text{mm}$.



The thinner the installation thickness and worktop, the more critical it is to ensure its bearing capacity and stability. The vented cooktop's weight combined with a full load of pots and their contents can weigh as much as 60kg. The worktop must be able to provide this level of stability. The worktop manufacturer's structural integrity specifications are to be taken into account.

Notes on planning ducted extraction



The high-pressure drop-resistant blower with EfficientDrive Brushless motor enables longer and more complex ducting scenarios up to 8 metres with four 90° bow elements and still offers adequate ventilation performance. This covers the majority of all ducted extraction planning. Even longer planning is possible, but will reduce the performance of the integrated ventilation system.



If the exhaust air is led through the outer wall, a mechanical telescopic wall outlet unit (Ø 150mm) with (integrated) backflow flap should be used. A maximum opening pressure of 65 Pa must be taken into account. The backflow flap and wall box can be obtained from specialist dealers.

Ensuring sufficient supply air is critical in a room air-dependent fireplace (if the appliance is planned and operated in ducted extraction mode).

Safe operation is only possible if the negative pressure in the room where the fireplace is located does not exceed 4 Pa (0.04 mbar). This can be achieved if, for example, a window contact switch is installed. This device allows the air required for combustion to flow in. The window contact switch can be obtained from specialist dealers. The installation instructions for the window contact switch must be observed.

The vented cooktop offers a connection option for a window contact switch with a two or three-phase connection. The supplied connection cable (5G2.5mm²) is installed, with a phase for a window contact switch available. With a connection 2N/3N, phase L1 (gray) corresponds to the fan motor. Hints can be found on the electrical connection diagram on the device ('fan').

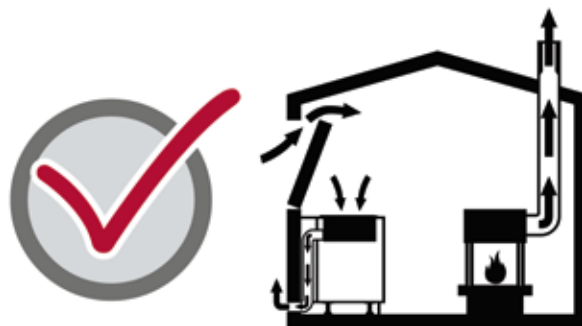

220-240V/380-415V 3N~

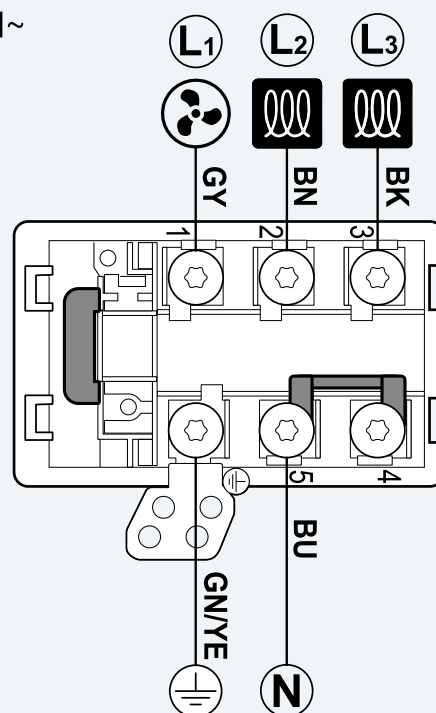

Exemplary connection diagram for a 3-phase electrical connection.

Specification diagrams

80CM INDUCTION COOKTOP WITH DOWNDRAFT VENTILATION – T58TL6EN2

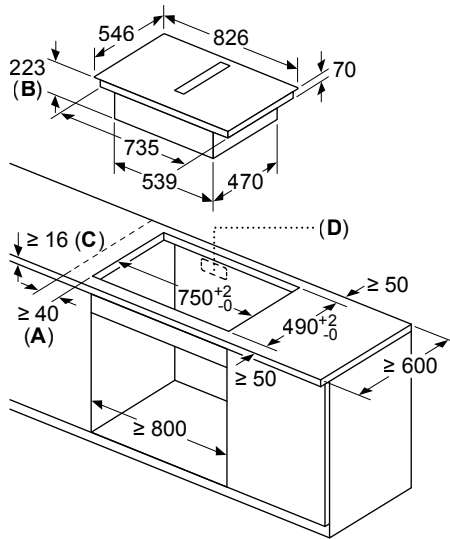

A – Minimum distance between cut-out and wall.

B – Immersion depth.

C – The worktop into which the appliance is installed should be able to withstand loads up to approximately 60kg – using suitable substructures, if necessary.

D – A cut-out in the cabinetry back panel is necessary for ducting. The exact size and position can be taken from specific drawings.

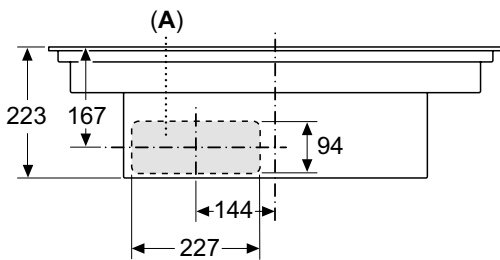

Dimensional drawings of the air outlet.

Front view.

DIMENSIONAL DRAWINGS FOR INSTALLATIONS IN (PARTLY) DUCTED RECIRCULATION AND DUCTED EXTRACTION CONFIGURATIONS

Z861KR0 Front view

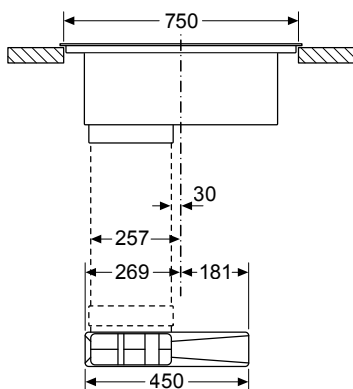

All additional ducting parts needed for this installation method are included in accessory kit **Z861KR0**.

Side view

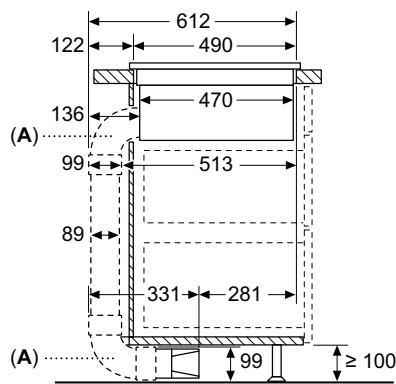

A – With 90° flat duct vertical (large radius) 17005034.

Side view

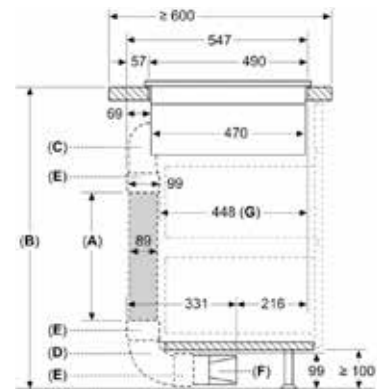

A – With 90° flat duct vertical (medium radius) 17006153.

B – With 90° flat duct vertical (large radius) 17005034.

All descriptions and technical diagrams are intended as a guide only. For additional information, full dimensional and installation details, please refer to the instruction and installation manuals supplied with the appliance, which can be accessed online for your planning purposes via www.neff.com.au. All measurements are in mm.

80CM INDUCTION COOKTOP WITH DOWNDRAFT VENTILATION – T58TL6EN2

Recommended for installation in an island bench or against an internal wall. When installing directly against outer walls that are not well insulated, it is recommended to use a partly or fully ducted recirculation configuration.

Position of cut out within the back panel of the cabinetry.

Front view

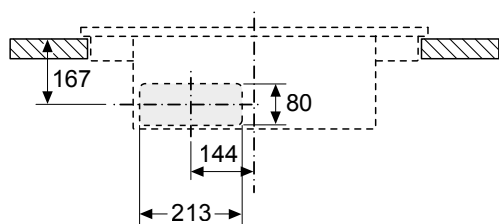

Side view

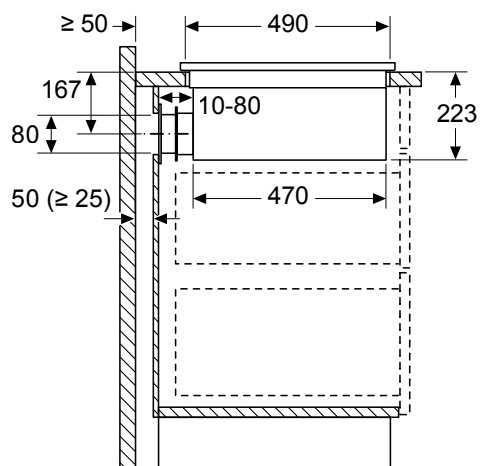

Typical planning scenario

For ducted installation

DUCTED INSTALLATION – SCENARIO 1

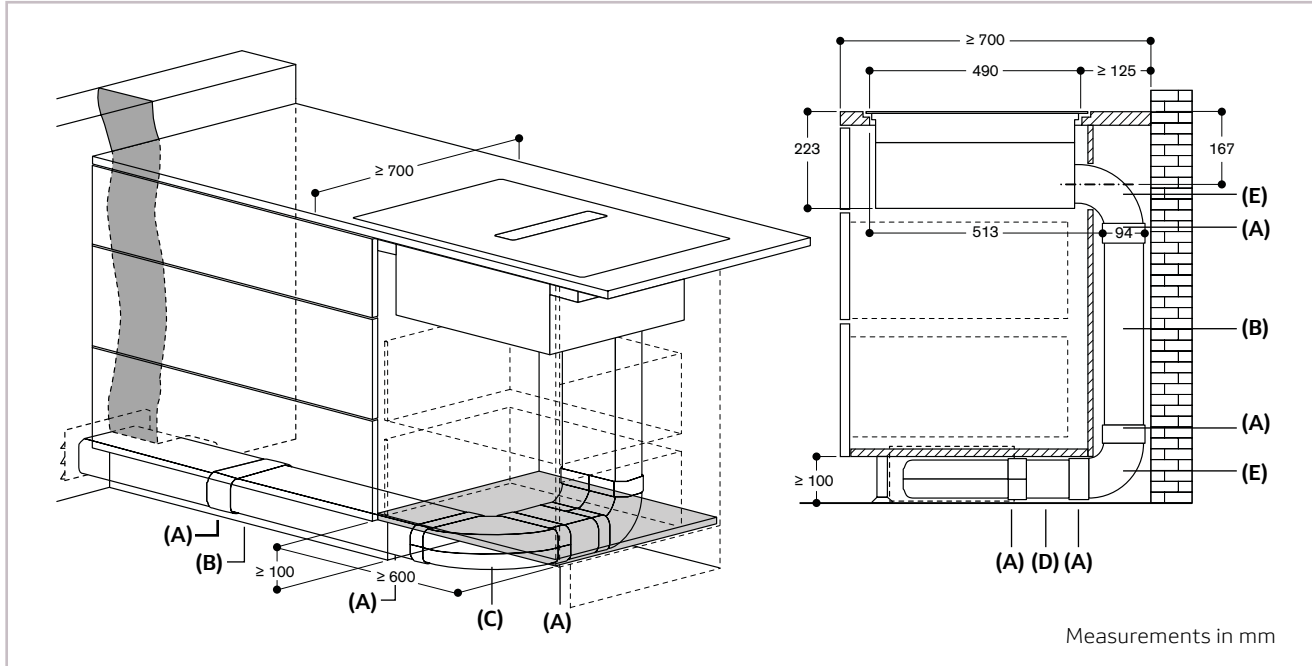

- A – Connector sleeve (female)
- B – Straight tube 1000mm
- C – 90° flat duct bend horizontal
- D – Straight tube 500mm
- E – 90° flat duct vertical (large radius)

DUCTED INSTALLATION – SCENARIO 2

We recommend using a back flap to avoid wind/insects/dust etc. entering the house.

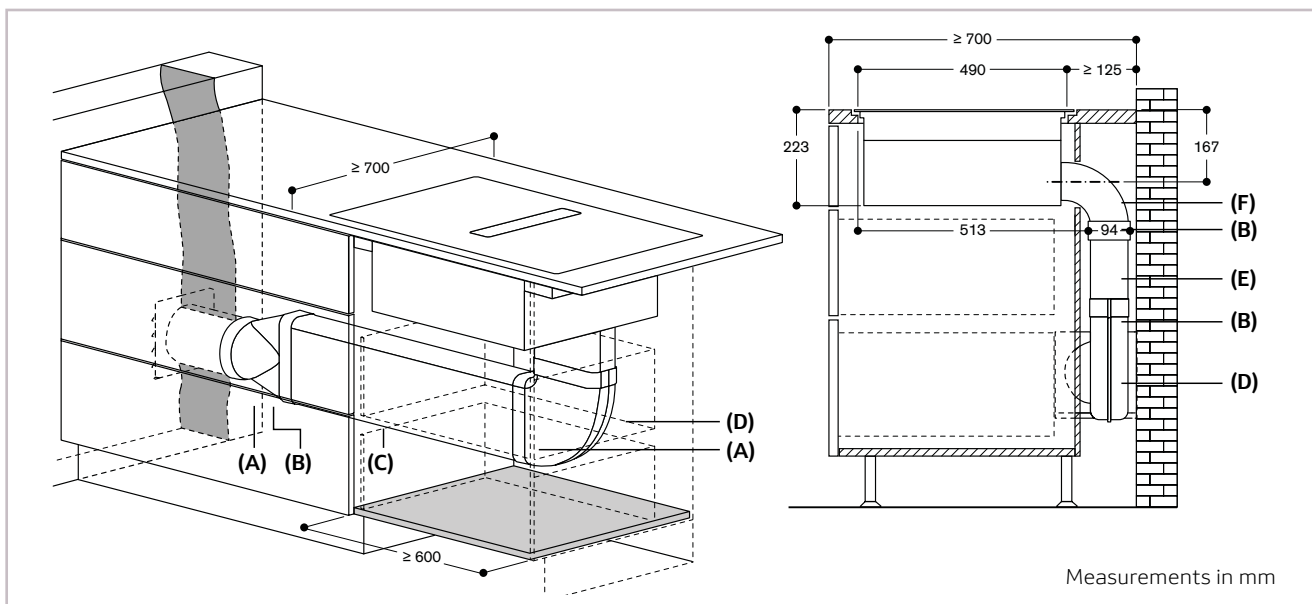

- A – Adapter round-flat (horizontal)
- B – Connector sleeve
- C – Straight tube 1000mm

- D – 90° flat duct bend horizontal
- E – Straight tube 500mm
- F – 90° flat duct vertical (large radius)

DUCTED INSTALLATION – SCENARIO 3

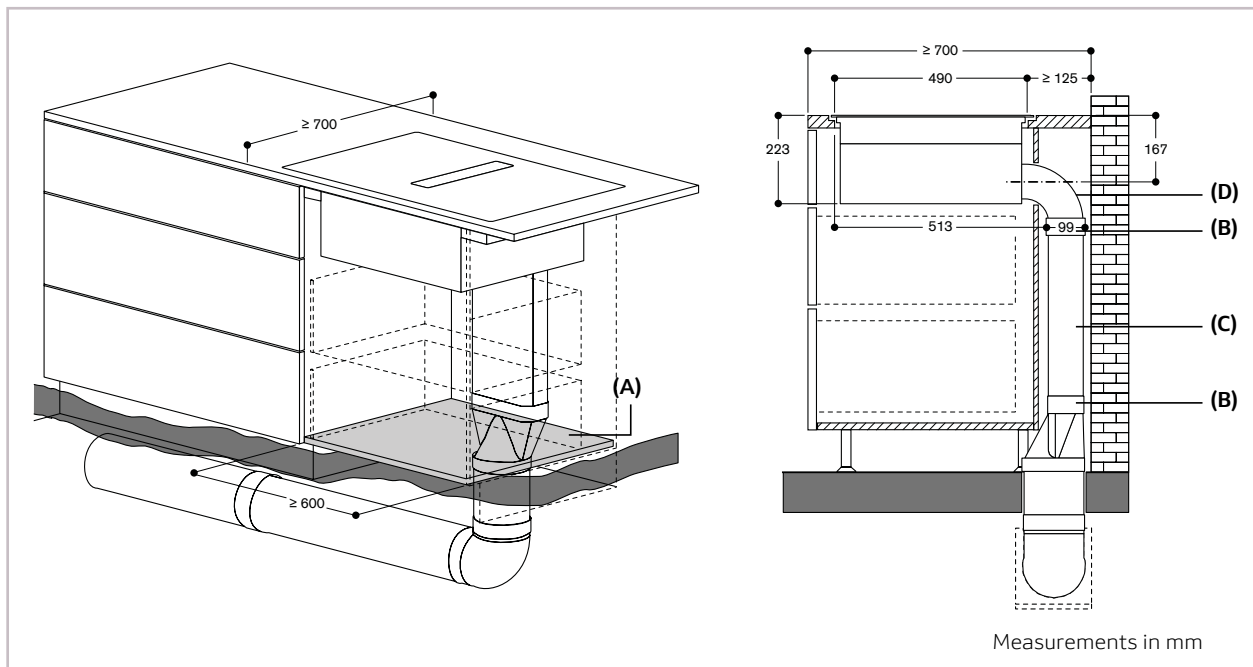

- A – Adapter round-flat (horizontal)
- B – Connector sleeve (female)
- C – Straight tube 1000mm
- D – 90° flat duct vertical (large radius)

Dimensional drawings for NEFF

Installation accessories & flat duct accessories

INCLUDED WITH APPLIANCE

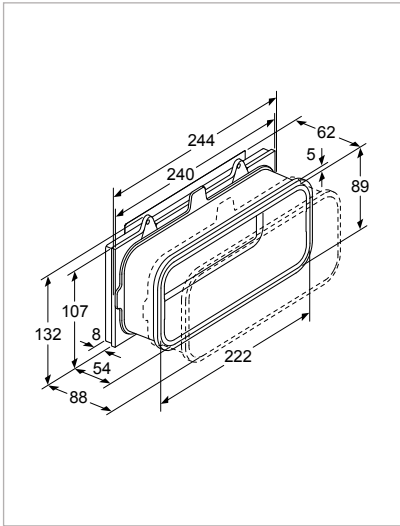

Telescopic slider element for unducted recirculation (Plug 'n Play)

FLAT DUCT ELEMENTS (MALE)

11037001

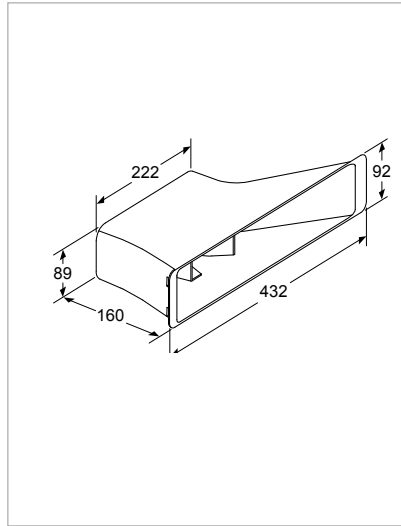

Diffuser element for partly or fully ducted recirculation

17005362

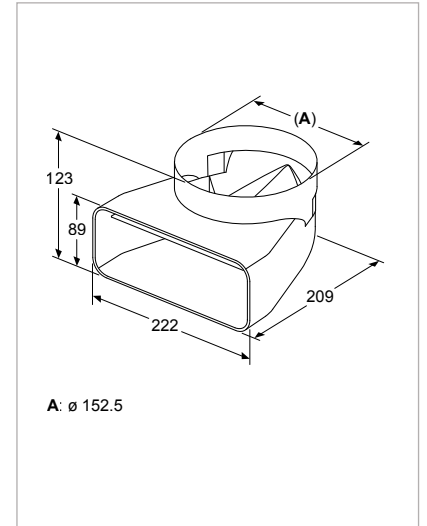

A: \varnothing 152.5

Male 90° adaptor element to combine round and flat duct elements

17005032

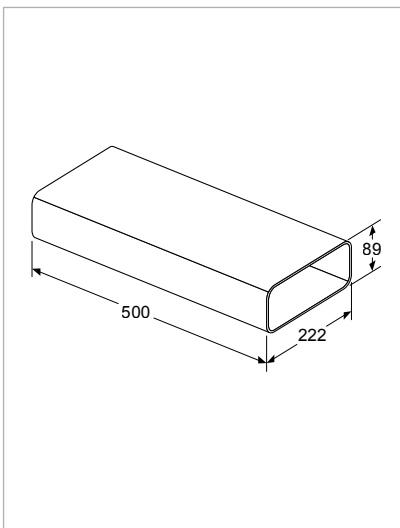

Straight tube element (male, 500mm).

17005033

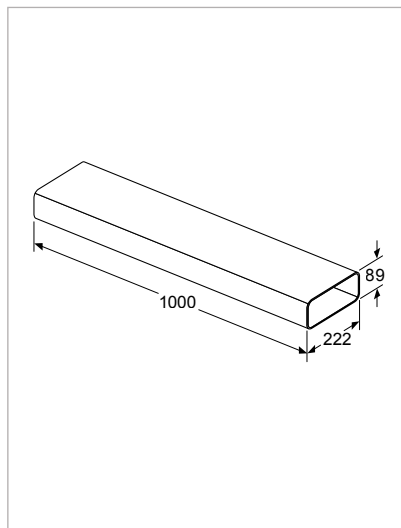

Straight tube element (male, 1000mm).

17005360

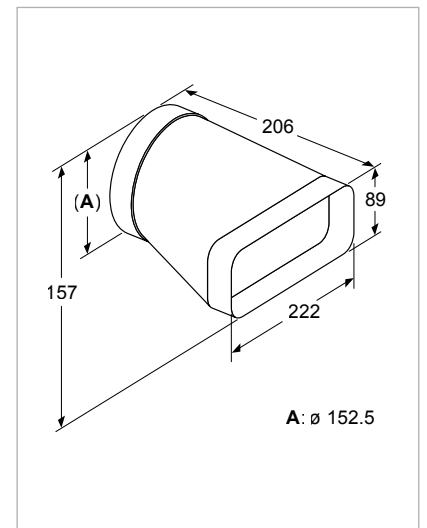

A: \varnothing 152.5

Male adaptor element to combine round and flat duct elements

All elements have an (outer) corner radius of 20mm.

Measurements in mm

17005356

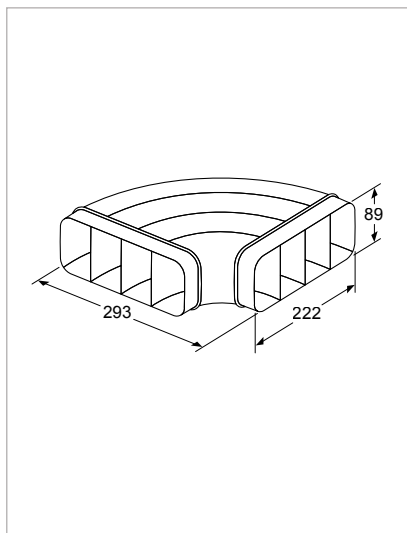

Horizontal 90° bow flat duct element (male).

FLAT DUCT ELEMENTS (FEMALE)

17005040

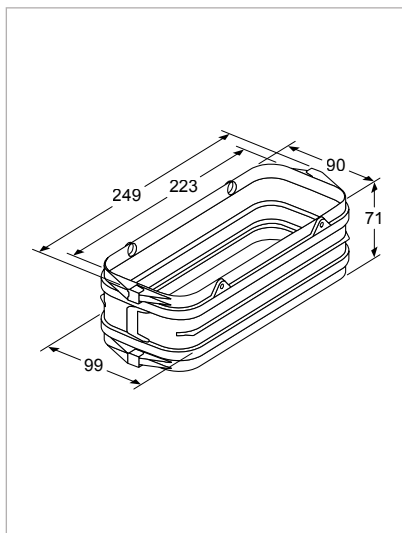

Connector sleeve (female) to combine male flat duct elements

17006154

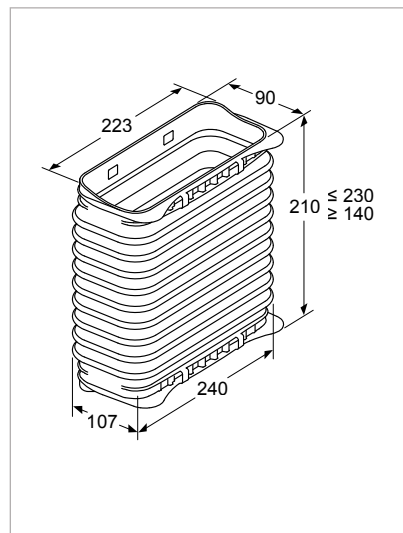

Flexible, female sleeve element to combine male flat duct elements

17006153

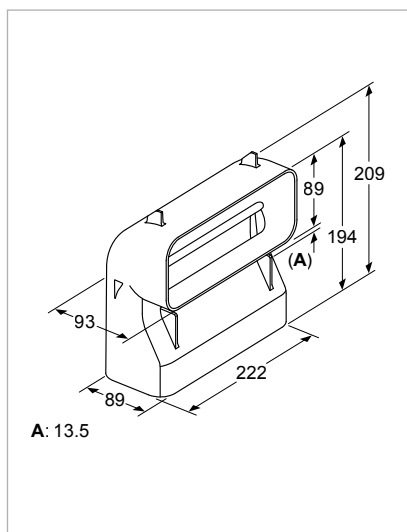

Vertical 90° 'S' bow flat duct element (male)

17005037

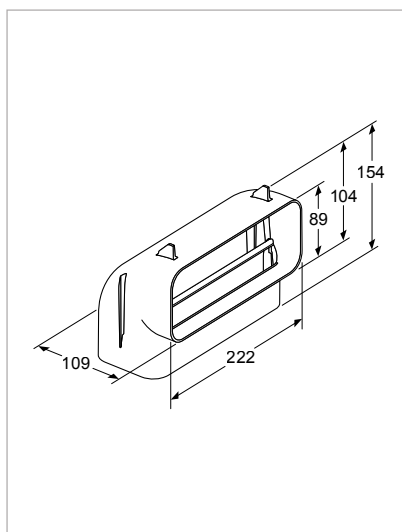

Vertical 90° 'M' bow flat duct element (male)

17005034

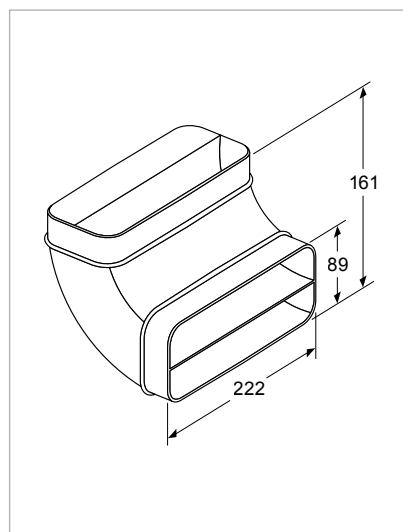

Vertical 90° 'L' bow flat duct element (male)

All elements have an (outer) corner radius of 20mm.

Measurements in mm



**4 YEAR
WARRANTY**

LEARN MORE ABOUT OUR PRODUCTS AT
WWW.NEFF.COM.AU

NEFF is proudly manufactured and distributed by BSH Home Appliances Pty Ltd.
For all enquiries please contact our NEFF Customer Care line on
1300 087 033 or visit www.neff.com.au

Printed in Australia. KRD 04/2022 – BH 5564 N