



COMPACT OVEN WITH MICROWAVE

[en] INSTRUCTION MANUAL

C67M70N3GB



Table of contents

Important safety information	4	Childproof lock	16
Causes of damage.....	6	Lock.....	16
Your new appliance	7	Permanent lock.....	16
Control panel.....	7	Automatic safety cut-out.....	16
Operating modes.....	7	Auto start	16
Cooking compartment.....	8	Basic settings	17
Your accessories	8	Changing the basic settings.....	17
Inserting accessories.....	8	Care and cleaning	17
After-sales service products.....	9	Cleaning agents.....	17
Before using the appliance for the first time	9	Cleaning the glass cover.....	18
Setting the language.....	9	Cleaning the glass panels.....	19
Setting the clock.....	9	Faults and repairs	19
Heating up the cooking compartment.....	9	Malfunction table.....	19
Cleaning the accessories.....	9	Replacing the oven light bulb.....	20
Switching the appliance on and off	10	Replacing the door seal.....	21
Switching on.....	10	After-sales service	21
Switching off.....	10	E number and FD number.....	21
Operating the appliance	10	Energy and environment tips	21
Setting the operating mode and temperature.....	10	Saving energy.....	21
MicroCombi, gentle / MicroCombi, intensive.....	10	Environmentally-friendly disposal.....	21
Heating indicator.....	11	Automatic programmes	22
Setting rapid heating.....	11	Ovenware.....	22
The microwave	12	Selecting a programme.....	22
Notes regarding ovenware.....	12	Adjusting individually.....	22
Microwave power settings.....	12	Defrosting and cooking with the automatic programmes.....	22
Setting the microwave.....	12	Tested for you in our cooking studio	27
Combination	13	Defrosting, heating up and cooking with the microwave.....	27
Suitable microwave power settings.....	13	Microwave tips.....	30
Setting a combination.....	13	Cakes and pastries.....	30
Series of operations	13	Baking tips.....	32
Ovenware.....	13	Roasting and grilling.....	32
Setting a series of operations.....	13	Tips for roasting and grilling.....	35
Memory	14	Bakes, gratins, toast with toppings.....	36
Saving settings in the memory.....	14	Convenience products.....	36
Starting the memory.....	14	Slow cooking	37
Electronic clock	14	Using low-temperature cooking.....	37
Clock display.....	14	Slow cooking.....	37
Minute minder.....	15	Tips for slow cooking.....	38
Cooking time.....	15	Test dishes	38
End of operation.....	15	Baking.....	38
Preset operation.....	15	Grilling.....	39
Setting the clock.....	15	Acrylamide in foodstuffs	39

Additional information on products, accessories, replacement parts and services can be found at www.neff-international.com and in the online shop www.neff-eshop.com

Important safety information

Read these instructions carefully. Only then will you be able to operate your appliance safely and correctly. Retain the instruction manual and installation instructions for future use or for subsequent owners.

This appliance is only intended to be fully fitted in a kitchen. Observe the special installation instructions.

Check the appliance for damage after unpacking it. Do not connect the appliance if it has been damaged in transport.

Only a licensed professional may connect appliances without plugs. Damage caused by incorrect connection is not covered under warranty.

This appliance is intended for domestic use only. The appliance must only be used for the preparation of food and drink. The appliance must be supervised during operation. Only use this appliance indoors.

Always slide accessories into the cooking compartment correctly. See "*Description of accessories*" in the instruction manual.

This appliance may be used by children over the age of 8 years old and by persons with reduced physical, sensory or mental capabilities or by persons with a lack of experience or knowledge if they are supervised or are instructed by a person responsible for their safety how to use the appliance safely and have understood the associated hazards.

Children must not play with, on, or around the appliance. Children must not clean the appliance or carry out general maintenance unless they are at least 8 years old and are being supervised.

Keep children below the age of 8 years old at a safe distance from the appliance and power cable.

Risk of fire!

- Combustible items stored in the cooking compartment may catch fire. Never store combustible items in the cooking compartment. Never open the appliance door if there is smoke inside. Switch off the appliance and unplug it from the mains or switch off the circuit breaker in the fuse box.
- A draught is created when the appliance door is opened. Greaseproof paper may come into contact with the heating ele-

ment and catch fire. Do not place greaseproof paper loosely over accessories during preheating. Always weight down the greaseproof paper with a dish or a baking tin. Only cover the surface required with greaseproof paper. Greaseproof paper must not protrude over the accessories.

- Using the appliance for anything other than its intended purpose is dangerous and may cause damage.
The following is not permitted: drying out food or clothing, heating slippers, grain or cereal pillows, sponges, damp cleaning cloths or similar.
For example, heated slippers and grain or cereal pillows may catch fire, even several hours after they have been heated. The appliance must only be used for the preparation of food and drinks.
- Food may catch fire. Never heat food in heat-retaining packages.
Do not leave food heating unattended in containers made of plastic, paper or other combustible materials.
Do not select a microwave power or time setting that is higher than necessary. Follow the information provided in this instruction manual.
Never use the microwave to dry food. Never defrost or heat food with a low water content, e.g. bread, at too high a microwave power or for too long.
- Cooking oil may catch fire. Never use the microwave to heat cooking oil on its own.
- The appliance becomes very hot. If the appliance is installed in a fitted unit with a decorative door, heat will accumulate when the decorative door is closed. Only operate the appliance when the decorative door is open.

Risk of explosion!

Liquids and other food may explode when in containers that have been tightly sealed. Never heat liquids or other food in containers that have been tightly sealed.

Risk of serious damage to health!

- The surface of the appliance may become damaged if it is not cleaned properly. Microwave energy may escape. Clean the appliance on a regular basis, and remove any food residue immediately. Always keep the cooking compartment, door seal,

door and door stop clean; see also section *Care and cleaning*.

- Microwave energy may escape if the cooking compartment door or the door seal is damaged. Never use the appliance if the cooking compartment door or the door seal is damaged. Contact the after-sales service.
- Microwave energy will escape from appliances that do not have any casing. Never remove the casing. For any maintenance or repair work, contact the after-sales service.
- Preparing dishes in the microwave without using a wire rack leads to overloading of the appliance. The glass cover may break. Always use a wire rack and appropriate accessories to prepare dishes.

Risk of electric shock!

- Incorrect repairs are dangerous. Repairs may only be carried out and damaged power cables replaced by one of our trained after-sales technicians. If the appliance is defective, unplug the appliance from the mains or switch off the circuit breaker in the fuse box. Contact the after-sales service.
- The cable insulation on electrical appliances may melt when touching hot parts of the appliance. Never bring electrical appliance cables into contact with hot parts of the appliance.
- Do not use any high-pressure cleaners or steam cleaners, which can result in an electric shock.
- When replacing the cooking compartment bulb, the bulb socket contacts are live. Before replacing the bulb, unplug the appliance from the mains or switch off the circuit breaker in the fuse box.
- A defective appliance may cause electric shock. Never switch on a defective appliance. Unplug the appliance from the mains or switch off the circuit breaker in the fuse box. Contact the after-sales service.
- The appliance is a high-voltage appliance. Never remove the casing.
- The insulation of an incompatible meat thermometer may be damaged. Only use the meat thermometer which is recommended for this appliance.

Risk of burns!

- The appliance becomes very hot. Never touch the interior surfaces of the cooking compartment or the heating elements. Always allow the appliance to cool down. Keep children at a safe distance.
- Accessories and ovenware become very hot. Always use oven gloves to remove accessories or ovenware from the cooking compartment.
- Alcoholic vapours may catch fire in the hot cooking compartment. Never prepare food containing large quantities of drinks with a high alcohol content. Only use small quantities of drinks with a high alcohol content. Open the appliance door with care.
- Foods with peel or skin may burst or explode during, or even after, heating. Never cook eggs in their shells or reheat hard-boiled eggs. Never cook shellfish or crustaceans. Always prick the yolk when baking or poaching eggs. The skin of foods that have a peel or skin, such as apples, tomatoes, potatoes and sausages, may burst. Before heating, prick the peel or skin.
- Heat is not distributed evenly through baby food. Never heat baby food in closed containers. Always remove the lid or teat. Stir or shake well after the food has been heated. Check the temperature of the food before it is given to the child.
- Heated food gives off heat. The ovenware may become hot. Always use oven gloves to remove ovenware or accessories from the cooking compartment.
- Airtight packaging may burst when food is heated. Always observe the instructions on the packaging. Always use oven gloves to remove dishes from the cooking compartment.

Risk of scalding!

- When you open the appliance door, hot steam may escape. Open the appliance door with care. Keep children at a safe distance.
- Water in a hot cooking compartment may create hot steam. Never pour water into the hot cooking compartment.
- There is a possibility of delayed boiling when a liquid is heated. This means that the liquid reaches boiling temperature without the usual steam bubbles rising to the surface. Even if the container only vibrates a little, the hot liquid may suddenly boil

over and spatter. When heating, always place a spoon in the container. This will prevent delayed boiling.

Risk of injury!

- Scratched glass in the appliance door may develop into a crack. Do not use a glass scraper, sharp or abrasive cleaning aids or detergents.
- Unsuitable ovenware may crack. Porcelain or ceramic ovenware can have small perforations in the handles or lids. These perforations conceal a cavity below. Any moisture that penetrates this cavity could cause the ovenware to crack. Only use microwave-safe ovenware.

Hazard due to magnetism!

The retractable control element is magnetic and may affect electronic implants, e.g. heart pacemakers or insulin pumps. For wearers of electronic implants: Do not stand right up against the appliance when you are making settings or cleaning.

Causes of damage

Caution!

- Creation of sparks: Metal - e.g. a spoon in a glass - must be kept at least 2 cm from the oven walls and the inside of the door. Sparks could irreparably damage the glass on the inside of the door.
- Baking tray, greaseproof paper, aluminium foil or ovenware on the cooking compartment floor: Do not place baking trays or ovenware on the cooking compartment floor. Do not line the cooking compartment floor with aluminium foil. This will cause heat accumulation. The baking and roasting times will no longer be correct and the enamel will be damaged.
- Foil containers: Do not use foil containers in the appliance. They damage the appliance by producing sparks.
- Water in the hot cooking compartment: Never pour water into the hot cooking compartment. This will cause steam. The temperature change can cause damage to the enamel.
- Moist food: Do not store moist food in the closed cooking compartment for long periods. This will damage the enamel. Do not use the appliance to store food. This can lead to corrosion.
- Fruit juice: When cooking very moist fruit flans, do not fill the universal pan too generously. Fruit juice which runs out of the universal pan leaves behind stains which cannot be removed.
- Cooling with the appliance door open: Only leave the cooking compartment to cool with the door closed. Do not trap anything in the appliance door. Even if the door is only slightly ajar, the fronts of adjacent units may be damaged over time.
- Condensation in the cooking compartment: Condensation may appear on the door window, interior walls and floor. This is normal and does not adversely affect microwave operation. To prevent corrosion, wipe off the condensation every time you cook.
- Heavily soiled seal: If the seal is very dirty, the appliance door will no longer close properly during operation. The fronts of adjacent units could be damaged. Always keep the seal clean.

- Using the appliance door for standing on or placing objects on: Do not stand or place anything on the open appliance door. Do not place ovenware or accessories on the appliance door.
- Transporting the appliance: Do not carry or hold the appliance by the door handle. The door handle cannot support the weight of the appliance and could break.
- Operating the microwave without food: Operating the appliance without food in the cooking compartment may lead to overloading. Never switch on the appliance unless there is food in the cooking compartment. An exception to this rule is a short crockery test (see the section "Microwave, suitable crockery").

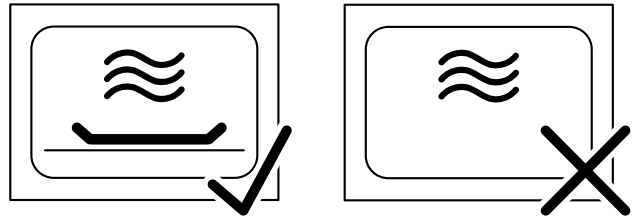

- Microwave popcorn: Never set the microwave power too high. Use a power setting no higher than 600 watts. Always place the popcorn bag on a glass plate. The disc may jump if overloaded.

Your new appliance

In this section, you will find information on

- the control panel
- the operating modes

- the shelf heights
- the accessories

Control panel

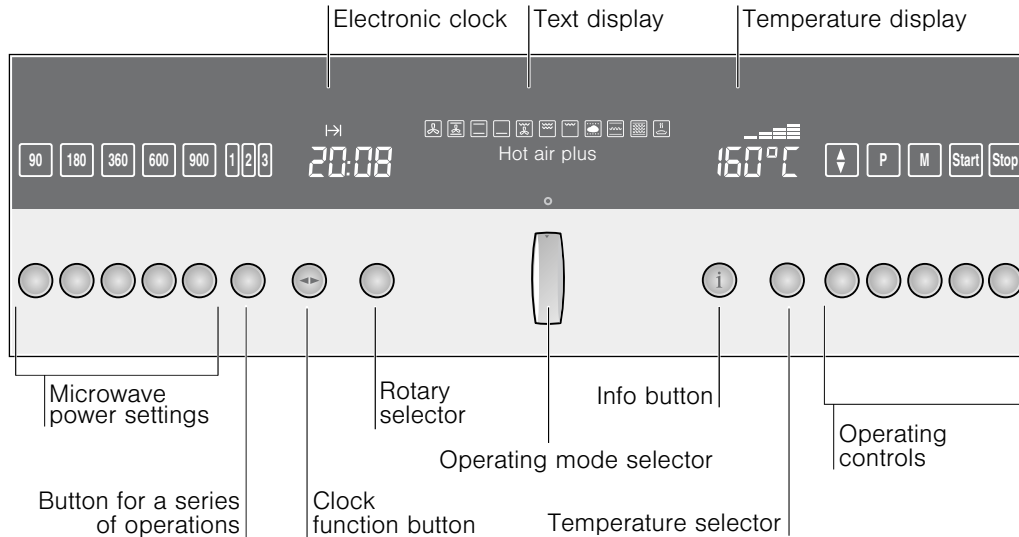

Operating controls	Use
90	Selects 90 watt microwave power
180	Selects 180 watt microwave power
360	Selects 360 watt microwave power
600	Selects 600 watt microwave power
900	Selects 900 watt microwave power
	Selects a series of operations
	Clock function button Selects the required clock function or rapid heat up (see section: <i>Electronic clock</i>)
	Rotary selector Makes the settings in one of the clock functions or switches on rapid heat up (see section: <i>Electronic clock</i>)
	Operating mode selector Selects the desired operating mode (see section: <i>Switching on the appliance</i>)
i	Info button Shows the current temperature during the heating up period (see section: <i>Switching on the appliance</i>) Opens the Basic Settings menu (see section: <i>Changing basic settings</i>)
	Temperature selector Sets the temperature (see section: <i>Switching on the appliance</i>) Changes the settings on the Basic Settings menu (see section: <i>Changing basic settings</i>)
	Navigation button Switches between lines on the text display.
P	Selects automatic programmes
M	Selects the memory
Start	Starts oven operation

Operating controls	Use
	Stops oven operation or cancels a setting

Microwave power settings and operating controls

When you press a button, the relevant item lights up on the display.





Retractable operating knob

The rotary, temperature and operating mode selectors can be pushed in and popped out. Press them towards the relevant operating knob to pop it in and out.

Operating modes

Below is an overview of the operating modes on your appliance.

Operating modes and temperature range	Application
Hot air 30-250 °C	For baking and roasting on one level.
Hot air plus 30-250 °C	For baking cakes and small baked items on two levels.
Top/bottom heat 30-270 °C	For baking and roasting on one level. Especially suitable for cakes with moist toppings (e.g. cheesecake).
Bottom heat 30-200 °C	For food and baked goods which should form a crust or which need more browning on the underside. Only activate Bottom heat for a short while at the end of the baking time.
Circo-roasting 100-250 °C	For poultry and larger pieces of meat.
Full-surface grill low (1) medium (2) high (3)	For large amounts of flat, small items for grilling (e.g. steaks, sausages).

Operating modes and temperature range	Application
 Centre-area grill low (1) medium (2) high (3)	For small amounts of flat, small items for grilling (e.g. steaks, bread).
 Low-temperature cooking 70-100 °C	For tender pieces of meat, that are to be cooked medium, medium rare or "à point".
 MicroCombi, gentle 30-250 °C	For sponge mixture in tins, short-crust pastry with moist filling and cakes made from baking mixtures. For oven operation, a lower microwave power setting is switched on automatically.
 MicroCombi, intensive 30-250 °C	For poultry, fish and bakes. When the oven is operating, a medium microwave power setting is automatically activated.
 Keep warm 60-100 °C	For keeping food warm. Caution! Warm food spoils more quickly. Do not keep the food warm for longer than two hours.

Cooking compartment

Your appliance has a cooling fan.

Cooling fan

The cooling fan switches on and off as required. The hot air escapes above the door.

Caution!

do not cover the ventilation slots. Otherwise the oven will overheat.

Notes

- The cooling fan continues to run for a certain time after operation.
- The appliance remains cool during microwave operation. The cooling fan will still switch on. The fan may run on even when microwave operation has ended.
- Condensation may appear on the door window, interior walls and floor. This is normal and does not adversely affect microwave operation. Wipe away the condensation after cooking.

Your accessories

The accessories supplied with your appliance are suitable for making many meals. Ensure that you always insert the accessories into the cooking compartment the right way round.

There is also a selection of optional accessories, with which you can improve on some of your favourite dishes, or simply to make working with your oven more convenient.

Inserting accessories

You can insert the accessories into the cooking compartment at 3 different positions.

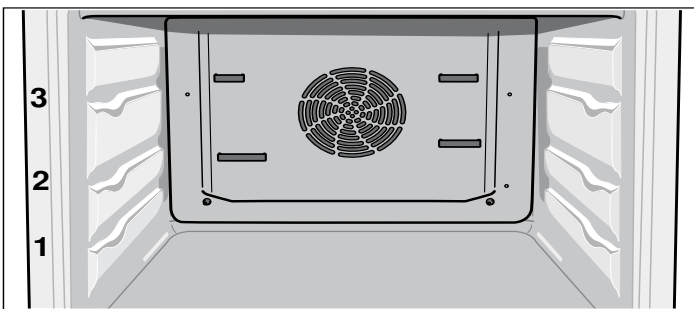

Notes

- The accessories can be pulled out approximately halfway without tipping. This allows dishes to be removed easily.
- When sliding in the accessories, ensure that the projection on the wire rack and on the universal pan is at the back.

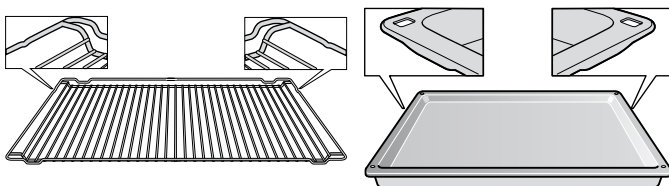

- The accessories can become deformed when they become hot. As soon as they have cooled down, the deformation disappears with no effect on the function.



Universal pan

For large joints, dry and moist cakes, bakes and gratins. It can also act as a splash guard if you are grilling meat directly on the wire rack. For this, slide the universal pan in at position 1.

Notes

- Insert the universal pan into the cooking compartment with the projection at the back.
- Slide the universal pan into the oven with the tapered edge facing the cooking compartment door.



Wire rack

For cookware made from glass, porcelain or microwave-safe plastic, cake tins, roasts and grilled food.

Notes

- Insert the wire rack into the cooking compartment with the projection at the back.
- Insert the wire rack with the open side facing the cooking compartment door and the elbow rail pointing downwards .
- Always insert the wire rack at level 1 for cooking in microwave mode.

Wire rack

For grilled food.

Always place the wire insert in the universal pan. This ensures that dripping fat and meat juices are collected.

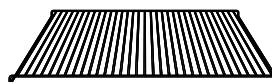

You can obtain further accessories from specialist retailers:

Accessories	Order number
Baking tray, enamelled	Z6360X0
Cleaning cloths for stainless steel surfaces	Article no. 311134
Oven/grill cleaning gel	Article no. 463582
Microfibre cloth with honeycomb structure	Article no. 460770

After-sales service products

You can obtain suitable care and cleaning agents and other accessories for your domestic appliances from the after-sales service, specialist retailers or (in some countries) online via the e-Shop. Please specify the relevant product number.

Reduces the build-up of dirt. Impregnated with a special oil for perfect maintenance of your appliance's stainless-steel surfaces.

For cleaning the cooking compartment. The gel is odourless.

Especially suitable for cleaning delicate surfaces, such as glass, glass ceramic, stainless steel or aluminium. The microfibre cloth removes liquid and grease deposits in one go.

Before using the appliance for the first time

In this section you will find out which steps are required before using the appliance for the first time:

- Setting the clock and language
- Cleaning the accessories before use

Setting the language

Once the appliance has been connected to the power supply, you must set the language for the text display.

1. Turn the temperature selector until the language you require appears on the text display.
2. Press and hold the **i** info button for a few seconds. Your setting is saved.

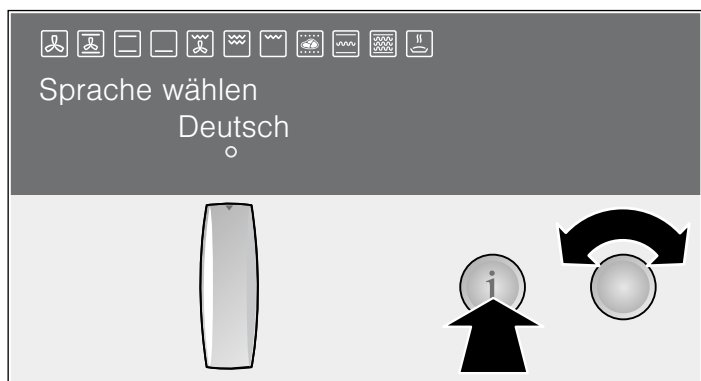

Changing the language

Requirement: the operating mode selector must not be pushed in.

1. Press and hold the **i** info button for a few seconds. This takes you directly to the language selection screen.
2. Turn the temperature selector until the language you require appears on the text display.
3. Press and hold the **i** info button for a few seconds. Your setting is saved.

Setting the clock

0:00 flashes in the clock display.

1. Press the clock function button. The **<>** and **☑** symbols light up. **12:00** appears in the clock display.
2. Turn the rotary selector to set the current time.



Your setting is automatically adopted after 3 seconds.

Changing the clock

To change the time subsequently, press the clock function button repeatedly until the **<>** and **☑** symbols light up again. Use the rotary selector to change the time.

Heating up the cooking compartment

To get rid of the new cooker smell, heat up the cooking compartment when it is empty and the oven door closed. Set **☐** Top/bottom heat and 240 °C.

Make sure that the cooking compartment contains no leftover packaging, e.g. polystyrene pellets.

Ventilate the kitchen while the oven is heating up.

1. Press the operating mode selector. "Appliance is ready for use" appears on the text display.
2. Using the operating mode selector, select **☐** Top/bottom heat.
3. Using the temperature selector, set the temperature to 240 °C
4. Press the **Start** button.
5. After 60 minutes, switch off the appliance using the operating mode selector.

Once the cooking compartment has cooled, clean it with hot, soapy water.

Cleaning the accessories

Before you use the accessories for the first time, clean them thoroughly with hot soapy water and a soft dish cloth.

Switching the appliance on and off

Use the operating mode selector to switch the compact microwave oven on and off.

Switching on

1. Press the operating mode selector.
"Appliance is ready for use" appears on the text display. The appliance switches on.
2. Select a function:
 - 90, 180, 360, 600 or 900 W button for a microwave power level

- button = series of operations
- Setting an operating mode and temperature
- button = automatic programmes
- button = memory programme

You can read how to make settings in the various sections.

Switching off

Turn the operating mode selector back to the 0 position and push it in. The oven switches off. A timer counting down or the residual heat in the cooking compartment is shown.

Operating the appliance

In this section, you can read about

- which operating modes are available for your oven.
- how to select an operating mode and temperature.
- how to set rapid heat up

Your compact microwave oven offers you a wide variety of operating modes. A default temperature always appears when you make a setting.

Operating mode	Suggested temperature in °C	Temperature range in °C
Hot air	160	30-250
Hot air plus	160	30-250
Top/bottom heat	180	30-270
Bottom heat	180	30-200
Circo-roasting	190	100-250
Full-surface grill	high (3)	medium (2) low (1)
Centre-area grill	high (3)	medium (2) low (1)
Slow cooking	80	70-100
MicroCombi, gentle	180	30-250
MicroCombi, intensive	200	30-250
Keep warm	70	60-100

Setting the operating mode and temperature

Example in picture:

Top/bottom heat, 200 °C.

1. Turn the operating mode selector until the desired operating mode appears in the text display.
A default temperature appears on the temperature display.
2. Turn the temperature selector to change the default temperature.

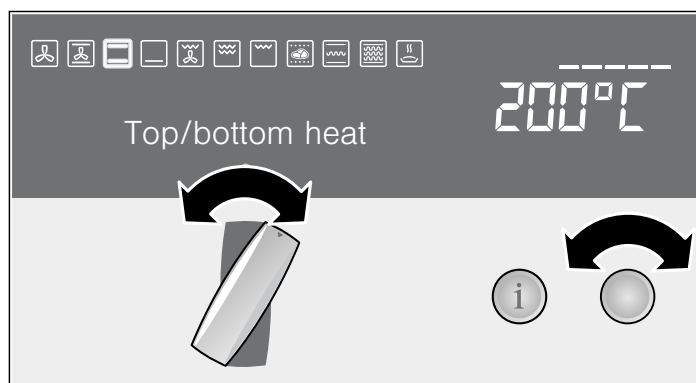

3. Press the button.

Appliance operation begins. The heating bars in the temperature indicator appear in the temperature display.

Switching off

When the meal is ready, switch off the oven using the operating mode selector or make new settings.

Changing the temperature or grill setting

This can be done at any time. Turn the rotary selector to change the temperature or grill setting.

Opening the oven door during cooking

Operation is suspended. flashes. After closing the door, press the button again. The programme will then continue.

Pausing operation

Press the button briefly. flashes. The oven is paused. Press the button again to continue operation.

Cancelling operation

Switch off the oven using the operating mode selector.

Notes

- If you also set a cooking time, the operation which you have set will automatically switch off at the end of this time. See the section *Electronic clock*.
- If you enter a cooking time and end time, the operation which you have set will automatically switch on and off. See the section *Electronic clock*.

MicroCombi, gentle / MicroCombi, intensive

For these types of heating, a microwave power setting is automatically switched on. You simply need to set the temperature specified in the recipe and halve the cooking time.

MicroCombi, gentle

MicroCombi, gentle is suitable for cakes in tins, such as

- Sponge cake, e.g. marble cake, fruit loaf, fruit flan
- Short-crust pastry with moist filling, e.g. apple pie, cheesecake
- Cakes made from baking mixtures
- Yeast cake, e.g. with currants
- For roasting, the cooking time can also be halved with this type of heating.

Note: Use dark metal baking tins or else plastic "FlexiForm" bakeware. For joints, a heat-resistant glass dish with or without a lid is suitable.

MicroCombi, intensive

This type of heating is suitable for

- poultry, e.g. chicken
- baked casseroles, e.g. pasta bake
- gratins, e.g. potato gratin
- grilled fish, fresh and frozen

Note: Use heat-resistant containers made of glass or ceramic.

Setting procedure

If there is information in the recipe for different types of heating, take the setting for Top/bottom heating. The cooking time specified in the recipe should not be less than 30 minutes.

Place your food in the cold cooking compartment. Place the ovenware in the centre of the wire rack at level 1.

1. Using the rotary selector, set the "MicroCombi, gentle" or "MicroCombi, intensive" heating type.
A preset cooking time of 20:00 minutes is suggested.
2. Use the temperature selector to set the temperature.
3. Press the clock function button repeatedly until the and I→I symbols light up.
4. Change the cooking time using the rotary selector.
5. Press the  button.

Appliance operation begins.

The cooking time has elapsed

A signal sounds. Operation has finished. You can stop the audible signal by pressing the  button. The clock display shows →I 0:00.

Heating indicator

The five bars in the heating indicator show the heating phase and the residual heat in the cooking compartment.

Current temperature

Press the  button. The current temperature is displayed for 3 seconds.

Heating phases

When the oven is started, five bars appear in the status bar. The set temperature has been reached when the last bar is filled.



If you have selected a grill setting or the microwave, the bars do not appear.

You can use the  button to check the current heating temperature while the oven is heating up. Due to thermal inertia, the temperature displayed may differ slightly from the actual temperature in the cooking compartment.

Residual heat indicator



You can see in the temperature display whether there is high or low residual heat in the cooking compartment.

Temperature display	Text display
H	Residual heat high
h	Residual heat low

Setting rapid heating

The rapid heat up function is not suitable for all operating modes.

Suitable operating modes





-  Hot air
-  Hot air plus and
-  Top/bottom heat

Suitable temperatures

Rapid heating will not work if the temperature is set to less than 100 °C. If the temperature in the cooking compartment is only slightly less than the temperature you have set, rapid heating is not necessary. It will not switch on.

Setting rapid heating

Condition: a suitable operating mode and temperature must have been set.

1. Set the operating mode and temperature.
2. Repeatedly press the clock function button until the  and  symbols light up and  appears on the clock display.
3. Turn the rotary selector clockwise.
The clock display shows  and the  symbol lights up. Rapid heat up is activated.

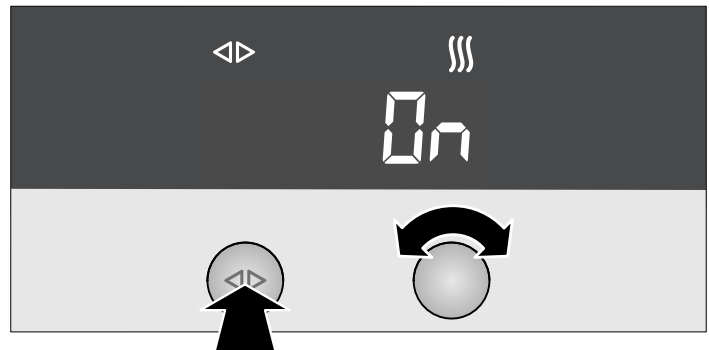

4. Press the  button.



The appliance heats up.

To ensure an even cooking result, do not place your food in the oven until rapid heat up is complete.

The rapid heat up process is complete

After reaching the set temperature, Rapid heat up switches off. The  symbol goes out. Put your food in the oven.

Cancelling rapid heat up

Press the clock function button repeatedly until  appears on the clock display. Turn the rotary selector anti-clockwise until  appears on the clock display. The  symbol on the clock display goes out.

Notes

- If you change an operating mode, rapid heat up is cancelled.

- You can use the **i** button to check the current cooking compartment temperature during rapid heating.

- Once a cooking time has been set, it will start counting down immediately after the oven is started, regardless of the rapid heat up function.
- If you open the oven door during cooking, rapid heat up is cancelled.

The microwave

Microwaves are converted to heat in foodstuffs. The microwave can be used solo, i.e. on its own, or in combination with a different type of heating.

In this section, you will find

- information about ovenware
- how to set the microwave

Notes

- In the *Tested for you in our cooking studio* section, you will find examples for defrosting, heating and cooking with the microwave oven.
- Always use a wire rack and appropriate accessories to prepare dishes.

Notes regarding ovenware

Suitable ovenware

Suitable dishes are heat-resistant ovenware made of glass, glass ceramic, porcelain, ceramic or heat-resistant plastic. These materials allow microwaves to pass through.

You can also use serving dishes. This saves you having to transfer food from one dish to another. You should only use ovenware with decorative gold or silver trim if the manufacturer guarantees that they are suitable for use in microwaves.

Unsuitable ovenware

Metal ovenware is unsuitable. Metal does not allow microwaves to pass through. Food in covered metal containers will remain cold.

Caution!

Creation of sparks: metal – e.g. a spoon in a glass – must be kept at least 2 cm from the oven walls and the inside of the door. Sparks could destroy the glass on the inside of the door.

Cookware test

Do not switch on the microwave unless there is food inside. The following cookware test is the only exception to this rule.

Perform the following test if you are unsure whether your cookware is suitable for use in the microwave:

1. Heat the empty cookware at maximum power for ½ to 1 minute on the wire rack at level 1.
2. Check the temperature during that time.

The cookware should be cold or warm to the touch.

The cookware is unsuitable if it becomes hot or sparks are generated.

Microwave power settings

Use the button to set the desired microwave power.

90 W	for defrosting delicate foods
180 W	for defrosting and continued cooking
360 W	for cooking meat and heating delicate foods
600 W	for heating and cooking food
900 watts	for heating liquids

Notes

- When you press a button, the selected power lights up.
- The microwave power can be set to 900 watts for a maximum of 30 minutes. With all other power settings, a maximum cooking time of 1 hour 30 minutes is possible.

Setting the microwave

Example: microwave power 600 W, cooking time 15 minutes

1. Press the operating mode selector.
“Appliance is ready for use” appears on the text display.
2. Press the button for the microwave power setting you require.
The button lights up and **1.00** minutes appears as the suggested figure on the clock display.
3. Set the cooking time using the rotary selector.
4. Press the **Start** button.

Appliance operation begins. The cooking time starts counting down.

The cooking time has elapsed

A signal sounds. Microwave operation has finished. You can stop the audible signal by pressing the **◀▶** button. Switch off or reset the appliance.

Changing the cooking time

This can be done at any time. Change the cooking time using the rotary selector.

Changing the microwave power setting

Press the button for the new microwave power setting. Use the rotary selector to set the cooking time and restart.

Opening the oven door during cooking

Operation is suspended. **Start** flashes. After closing the door, press the **Start** button. The programme will then continue.

Pausing operation

Press the **Stop** button briefly. **Start** flashes. The oven is paused. Press the **Start** button again, operation continues.

Cancelling operation

Press the **Stop** button twice, or press and hold the **Stop** button, until the “Appliance is ready for use” heading appears. You can now change the settings.

Note: If you open the appliance door during cooking, the fan may continue to run.

Combination







This involves the simultaneous operation of another operating mode with the microwave. Using the microwave makes your meals ready more quickly, and still browns them nicely.

You can set a cooking time of up to 1 hour 30 minutes.

In this section, you can read about

- which operating modes and microwave power settings are suitable
- how to set combination mode

Suitable operating modes

-  Hot air
-  Hot air plus
-  Top/bottom heat
-  Circo-roasting
-  Full-surface grill
-  Grill, small

Note: Rapid heat up cannot be switched on in combination mode.

Suitable microwave power settings

All microwave power settings, except for 900 watts, can be combined with an operating mode.

Setting a combination

Example: microwave 360 W, 17 minutes and  Top/bottom heat 200 °C.

1. Turn the operating mode selector until  Top/bottom heat appears on the text display.
The temperature display suggests 180 °C.
2. Set the temperature selector to 200 °C.

3. Press the button for the microwave power setting you require.
The clock display shows **15:00** mins and the **I→I** symbol.
4. Set the cooking time using the rotary selector.
5. Press the  button.

Appliance operation begins. The cooking time starts counting down.

The cooking time has elapsed

A signal sounds. Combination operation has finished. You can stop the audible signal by pressing the **◀▶** button. Switch off or reset the appliance.

Changing the temperature or grill setting

This can be done at any time. Turn the rotary selector to change the temperature or grill setting.

Changing the microwave power setting

Press the button for the new microwave power setting. Use the rotary selector to set the cooking time and restart.



Opening the oven door during cooking

Operation is suspended.  flashes. After closing the door, press the  button. The programme will then continue.

Pausing operation

Press the  button briefly.  flashes. The oven is paused. Press the  button again, operation continues.

Cancelling operation

Press the  button twice, or press and hold the  button, and switch off using the operating mode selector.

Note: If you also enter an end time, the operation which you have set will switch on and off automatically. See the section *Electronic clock*.

Series of operations

You can use the SeriesOperations function to set up to three operating modes and then start.

Requirement: you must set a cooking time for each step.

Can be used with:







- all microwave power settings
- combination mode

Ovenware

Always use microwave-safe, heat-resistant ovenware.

Setting a series of operations

Requirement: the operating mode selector must not be pushed in.

1. Press the  button.
The  for the first operation in the series lights up.
2. Set the first microwave power setting and cooking time.
3. Press the  button again.
The  for the second operation in the series lights up.
4. Set the second microwave power setting and cooking time.
5. Press the  button again.
The  lights up for the third operation in the series.
6. Set the third microwave power setting and cooking time.

7. Press the  button.

Appliance operation begins. The clock display shows the cooking time of the first operation in the series. The  for the first operation in the series lights up.

Checking the total or remaining cooking time

Press the clock function button **◀▶** twice to display the remaining cooking time.

The cooking time has elapsed

A signal sounds. The series of operations is finished. To stop the signal, press the  button. Switch off or reset the appliance.

Opening the oven door during cooking

Operation is suspended.  flashes. After closing the door, press the  button. The programme will then continue.

Changing the setting

Changes can only be made before operation begins. Press the  button to go to the desired setting, and make the changes.

Note: You can also combine an operating mode with the SeriesOperations function. First, set the oven operating mode.

Memory

Memory gives you the option to store your own settings and call them up again at the press of a button. There are six memory locations available. The memory function is useful for recipes which you prepare particularly frequently.

In this section, you can read about

- how to save the memory
- how to start the memory

Saving settings in the memory

Requirement: the operating mode selector must not be pushed in.

1. Set the operating mode, temperature and cooking time for the meal you wish to cook or select a programme. Do not start.
2. Press the **M** button.
“Memory 1 - free” appears.
3. Using the operating mode selector, select one of the six memory locations.
4. Press and hold the **M** button, a signal sounds and “Memory saved” appears.

Starting the memory

You can start cooking at any time using the settings saved for your meal.

Requirement: the operating mode selector must not be pushed in.

Place your food in the cooking compartment.

1. Press and release the **M** button and use the rotary selector to select the memory location.
The stored settings are displayed. If “Memory location empty” appears, no setting has been saved in this memory location yet.
2. Press the **Start** button.
The memory setting starts.

Changing the memory location

Once operation has started, you can no longer change the memory location.

Changing the settings

This can be done at any time. The setting you originally saved appears the next time you start the memory.

Electronic clock

Your appliance has various clock functions.

In this section, the following are explained:

- The clock display
- How to set the timer
- How to switch off your appliance automatically (cooking time and end of operation)
- How to switch your appliance on and off automatically (preselection mode)
- How to set or change the clock.

Clock display

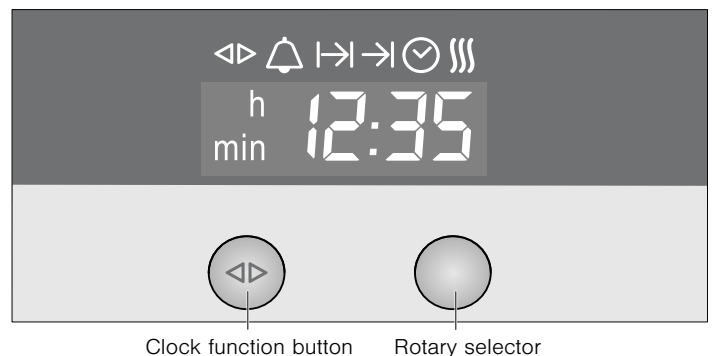



Clock function	Use
Timer	You can use the minute minder as an egg timer or a kitchen timer. The appliance does not switch on or off automatically
Cooking time	The appliances switches off automatically after a cooking time setting has elapsed (e.g. 1:30 hours)
End of operation	The appliance switches off automatically at a set time (e.g. 12:30)
Preset operation	The appliance switches on and off automatically. Cooking time and end of operation have been combined.
Clock	Setting the clock
Rapid heat up	Shortens the heat up time

Notes

- Between the times **22:00** and **5:59** the clock display is dimmed if you do not make any settings in that period or no clock function is activated.
- When using the minute minder , cooking time , end time and preselection mode clock functions, a signal sounds and the corresponding symbol flashes when the set time has expired. To stop the audible signal early, press the clock function button.
- You can check your settings at any time. Press the clock function button repeatedly until the corresponding symbol lights up.
- If you wish to cancel a setting, turn the set time back to **0:00** and switch the appliance off.
- The setting can be corrected using the rotary selector if necessary.



Switching the clock display on and off

Turn the operating mode selector back to the 0 position and push it in.

1. Press and hold the clock function button  for a few seconds.
The clock display is switched off. If a clock function is active, the associated symbol remains illuminated.
2. Press and hold the clock function button  for a few seconds.

The clock display switches on.

Minute minder



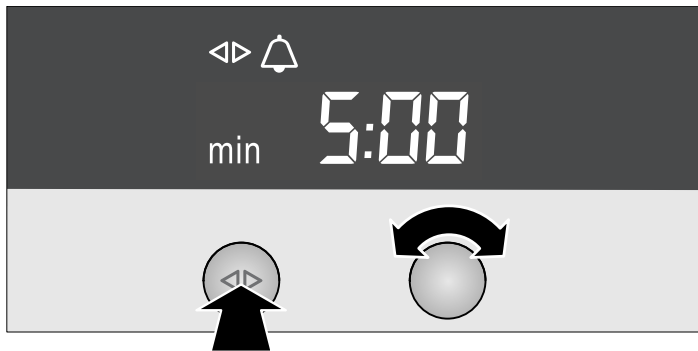

1. Press the clock function button  repeatedly until the  and  symbols light up.
2. Use the rotary selector to set the cooking time (e.g. **5:00** minutes).

The setting is applied automatically. Afterwards, the clock is displayed again and the timer counts down.



Cooking time

Automatic switch off after a certain period of time.

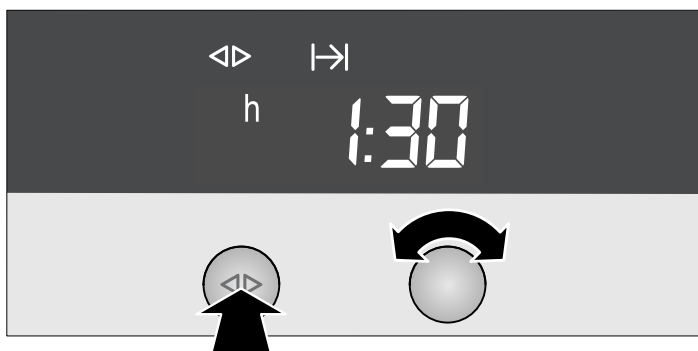

1. Set the operating mode and temperature.
2. Press the clock function button  repeatedly until the  and  symbols light up.
3. Set the cooking time using the rotary selector (e.g. **1:30** hours).
4. Press the  button.
The appliance heats up.





5. Turn operating mode selector to o position and press in.
Once operation time has elapsed, the appliance switches off automatically.

End of operation

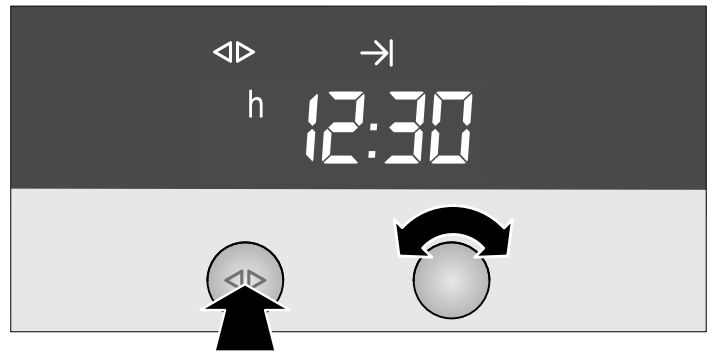

Automatic switch-off at a set time.









1. Set the operating mode and temperature.
2. Press the clock function button  repeatedly until the  and  symbols light up.
3. Set the end of operation using the rotary selector (e.g. **12:30**).





4. Press the  button.
The appliance switches off automatically at the time that has been set for the end of operation.
5. Turn operating mode selector to o position and press in.

Preset operation

The appliance switches on automatically, then switches off automatically at the time preselected for the end of operation. To set this function, combine the clock functions for cooking time  and end of operation .

1. Set the operating mode and temperature.
2. Press the clock function button  repeatedly until the  and  symbols light up.
3. Set the cooking time using the rotary selector (e.g. **1:30** hours).
4. Press the clock function button  repeatedly until the  and  symbols light up.
5. Set the end of operation using the rotary selector (e.g. **12:30**).
6. Press the  button.
The appliance waits until the appropriate time to switch on (in the example shown, **1:00**).
The appliance switches off automatically at the time set for the end of operation (**12:30**). A signal sounds and the  symbol flashes.
7. Turn operating mode selector to o position and press in.

Setting the clock

1. Press the clock function button  repeatedly until the  and  symbols light up.
2. Turn the rotary selector to set the current time.



The setting is applied automatically.

Changing the clock

e.g. from British Summer Time to Greenwich Mean Time.
Make the settings as described in steps 1 and 2.

Childproof lock

The oven has a childproof lock to prevent children from switching it on by accident or changing an operation that is already in progress.

In this section, you can read about

- how to lock your appliance
- how to lock your appliance permanently

Lock

To switch the appliance on again, you must unlock it. The appliance is not locked automatically after operation. Lock it again if necessary or activate the permanent lock.

Locking the appliance

1. Press the operating mode selector.
“Appliance is ready for use” appears on the text display.
2. Press and hold the Info button **i**.
“Select language” appears on the text display.
3. Press the Info button **i** again.
c 10 appears on the temperature display.
4. Turn the temperature selector until **c 11** appears on the temperature display.
5. Press and hold the **i** Info button until the **↔** symbol appears on the temperature display.

Note: If you attempt to make settings, **-5-** appears on the temperature display and “Appliance controls locked” on the text display.

Unlocking the appliance

1. Press the operating mode selector.
2. Press and hold the **i** Info button until **c 11** appears on the temperature display.
3. Turn the temperature selector until **c 10** appears on the temperature display.
4. Press and hold the **i** Info button until the **↔** symbol goes out.

Permanent lock

To make settings, you must temporarily interrupt the permanent lock. Once you have switched off your appliance, it locks again automatically.

Locking the appliance permanently

1. Press the operating mode selector.
“Appliance is ready for use” appears on the text display.
2. Press and hold the Info button **i**.
“Select language” appears on the text display.
3. Press the Info button **i** again.
c 10 appears on the temperature display.

4. Turn the temperature selector until **c 21** appears on the temperature display.

5. Press and hold the Info button **i**.

“Appliance is ready for use” appears on the text display.

Your appliance will be locked after 30 seconds. The **↔** symbol appears on the temperature display.

Note: If you attempt to make settings, **-5P-** appears on the temperature display and “Appliance controls permanently locked” on the text display.

Interrupting the permanent lock

1. Press the operating mode selector.
“Appliance is ready for use” appears on the text display.
2. Press and hold the **i** Info button until **c 21** appears on the temperature display.
3. Turn the temperature selector until **c 20** appears on the temperature display.
4. Press and hold the **i** Info button until the **↔** symbol goes out.
The permanent lock is interrupted.
5. Switch the appliance on within 30 seconds.

The permanent lock is activated again once the appliance is switched off.

Unlocking the appliance permanently

1. Press the operating mode selector.
“Appliance is ready for use” appears on the text display.
2. Press and hold the **i** Info button until **c 21** appears on the temperature display.
3. Turn the temperature selector until **c 20** appears on the temperature display.
4. Press and hold the **i** Info button until the **↔** symbol goes out.
5. Within 30 seconds, press and hold the **i** Info button again for a few seconds.
6. Turn the temperature selector until **c 10** appears on the temperature display.
7. Press and hold the Info button **i**.

The appliance is permanently unlocked.

Automatic safety cut-out

The automatic safety cut-out is only activated if you have not made any settings on your appliance for a prolonged period. You can adjust the period of time after which your appliance shuts off.

“Safety cut-out” appears in the text display and **000** flashes in the temperature display. Appliance operation is interrupted.

Turn the operating mode selector to the **O** position to deactivate it.

Auto start

Your appliance is set in such a way that you must press the **Start** button, so that the set oven operation starts.









With “Auto start”, oven operation starts automatically after the oven door is closed.

In the section “*Changing basic settings*”, you can read about how to change to Auto start mode.

Basic settings

Your appliance has various basic settings, which you can adjust to suit your needs at any time.

Note: In the table, you will find all the basic settings and options for changing them. Only the basic settings that correspond to the features of your specific appliance are displayed.

	Basic setting	Options	Explanation
-	Select language: English	12 other languages are possible	Language for the text display
c 1	0 = appliance controls unlocked	1 = appliance controls permanently locked	Activating the childproof lock
c 2	0 = appliance controls unlocked one-time	1 = appliance controls permanently locked	Activating the childproof lock permanently
c 3	2 = audible signal, medium	0 = off 1 = short = 30 seconds 2 = medium = 2 minutes 3 = long = 10 minutes	Signal after the cooking time has elapsed
c 4	0 = Continue when door shut: off	1 = automatic 0 = off*	Way in which operation is continued when the oven door is opened and closed again *Continue operation with 
c 5	Adjust individually -3     +3	e.g. increasingly well done cooking result -3     +3	Change the cooking result for all automatic programmes to the right = more intensive to the left = less intensive
c 6	Set the mains voltage 1 = 220-230V	2 = 230-240 V	Adjust the mains voltage
c 7	1 = do not restore factory settings	2 = restore factory settings	Reverse all changes and restore basic settings.

Changing the basic settings

Requirement: the operating mode selector must not be pushed in.

1. Press and hold the **i** button for a few seconds.
The first basic setting is displayed on the text display.

2. Press the **i** button repeatedly until the required basic setting is shown.
 3. Use the temperature selector to make the desired setting.
 4. Press and hold the Info button **i** for a few seconds.
Your setting is applied.
- You can change the settings at any time.

Care and cleaning

With careful care and cleaning your microwave oven will retain its looks and remain good order. We will explain here how you should care for and clean your appliance correctly.

Risk of electric shock!

Do not use any high-pressure cleaners or steam cleaners, which can result in an electric shock.

Risk of burns!

The appliance becomes very hot. Never touch the interior surfaces of the cooking compartment or the heating elements. Always allow the appliance to cool down. Keep children at a safe distance.

Notes

- Slight differences in colour on the front of the appliance are caused by the use of different materials, such as glass, plastic and metal.
- Shadows on the door panel which look like streaks, are caused by reflections made by the oven light.
- Enamel is baked on at very high temperatures. This can cause some slight colour variations. This is normal and does not affect their function. The edges of thin trays cannot be

completely enamelled. As a result, these edges can be rough. This will not impair the anti-corrosion protection.

- Unpleasant odours, e.g. after fish has been prepared, can be removed very easily. Add a few drops of lemon juice to a cup of water. Place a spoon into the container as well, to prevent delayed boiling. Heat the water for 1 to 2 minutes at maximum microwave power.

Cleaning agents

To ensure that the different surfaces are not damaged by using the wrong cleaning agent, observe the information in the table. Do not use

- sharp or abrasive cleaning agents,
- metal or glass scrapers to clean the glass in the appliance door,
- metal or glass scrapers to clean the door seal,
- hard scouring pads and sponges,
- cleaning agents with high concentrations of alcohol.

Wash new sponge cloths thoroughly before use.

Area	Cleaning agents
Control panel	Hot soapy water: Clean with a dish cloth and dry with a soft cloth. Do not use glass cleaners or metal or glass scrapers for cleaning.
Stainless steel	Hot soapy water: Clean with a dish cloth and dry with a soft cloth. Remove flecks of limescale, grease, starch and albumin (e.g. egg white) immediately. Corrosion can form under such residues. Special stainless steel cleaning agents can be obtained from the after-sales service or from specialist shops.
Oven	Hot soapy water or a vinegar solution: Clean with a dish cloth and dry with a soft cloth. If oven is very dirty: use oven cleaner, but only when oven is cold. It is best to use a stainless-steel sponge.
Glass cover for the oven light	Hot soapy water: Clean with a dish cloth.
Outer door panel	Glass cleaner: Wipe dry immediately using a soft cloth. Do not use a glass scraper.
Inner door glass	Glass cleaner: Wipe dry with a soft cloth. Do not use a glass scraper.
Seal	Hot soapy water: Clean with a dish cloth, do not scour. Do not use a metal or glass scraper for cleaning.
Accessories	Hot soapy water: Soak and clean with a dish cloth or a brush.

Cleaning the self-cleaning surfaces in the cooking compartment

The back wall and ceiling are coated with self-cleaning enamel. They clean themselves while the oven is in operation. Sometimes, larger splashes of food may not disappear until the oven has been operated several times.

Notes

- Never treat the self-cleaning surfaces with oven cleaner. If oven cleaner accidentally gets onto the back wall or ceiling, remove it immediately with a sponge and plenty of water.
- Never use abrasive cleaning agents. You will scratch or destroy the highly porous coating.
- Never treat the self-cleaning surfaces with a scouring pad.
- Light discolouration of the enamel does not affect self-cleaning.

Cleaning the cooking compartment floor and side walls

Use a dish cloth and hot soapy water or a vinegar solution.

If there are heavy deposits of dirt, use a stainless steel scouring pad or oven cleaner. Only use in a cold oven.

Cleaning the glass cover

The glass cover can be removed from the oven ceiling for cleaning.

⚠ Risk of burns!

Do not remove the panels immediately after switching the appliance off. The oven must be cold.

Removal

1. Place a tea towel in the oven.

2. Pull the clip on the oven ceiling forwards. (Fig. A)
Press the front of the glass cover down using the thumb of your other hand. Let go of the clip.
3. Slide the cover forwards using both hands and rest it on the grill element. (Fig. B)

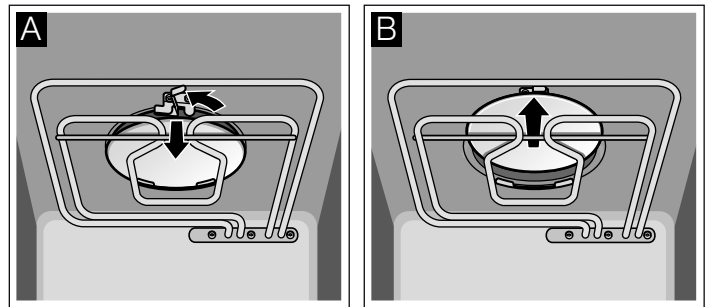

4. Slide it slightly backwards again. (Fig. C)
5. Tilt down at the side and remove. (Fig. D)

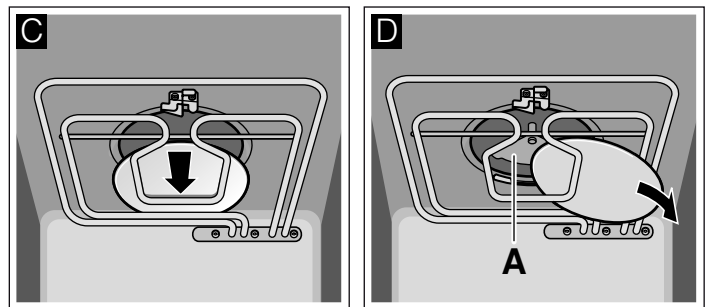

⚠ Risk of injury!

Never touch or clean the microwave antenna (A)!

For light soiling:

Wash the glass cover using hot soapy water.

For heavy soiling:

Clean the glass cover in the same way as the enamel surfaces in the oven.

Refitting

1. Slide in the cover with the smooth side facing downwards and rest it on the grill element. (Fig. A)
2. Use both hands to slide it back into the two catches. (Fig. B).

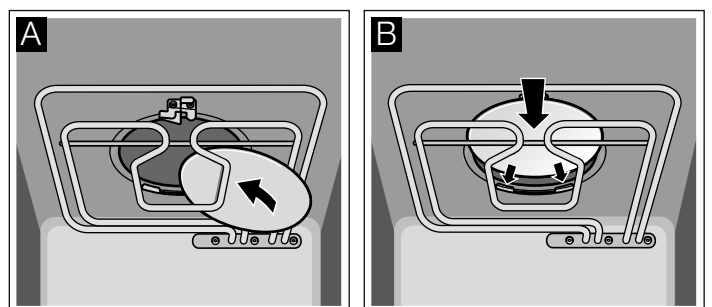

3. Pull the clip forwards and push the glass cover upwards. Let go of the clip. (Fig. C)

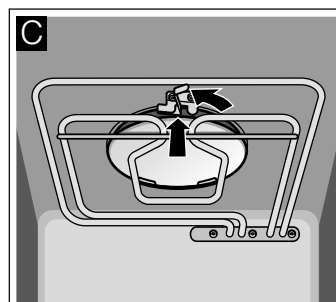

Remove the tea towel from the oven.

⚠ Risk of serious damage to health!

Never operate the appliance without the microwave glass cover. Microwave energy may escape.

Cleaning the glass panels

The glass panels can be removed from the oven door for cleaning.

⚠ Risk of burns!

The appliance becomes very hot. Never touch the interior surfaces of the cooking compartment or the heating elements. Always allow the appliance to cool down. Keep children at a safe distance.

Removal

1. Open the oven door.
2. Undo the two screws on the door using a TORX screwdriver (TORX 20). Hold the door panel firmly while doing this (Fig. A).
3. Position the door at an angle and pull out the panel upwards by the door handle. (Fig. B).

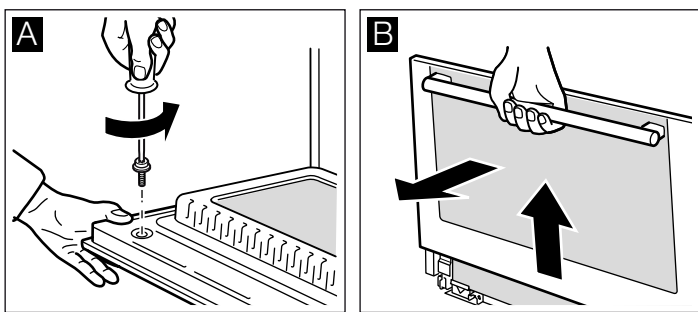

4. Close the door.

Note: Clean the glass panels with glass cleaner and a soft cloth.

⚠ Risk of injury!

Scratched glass in the appliance door may develop into a crack. Do not use a glass scraper, sharp or abrasive cleaning aids or detergents.

Refitting

1. Insert the door panel into the guide with both hands. (Fig. A).
2. Push the door panel downwards, lift it slightly and hook it in at the top (Fig. B).

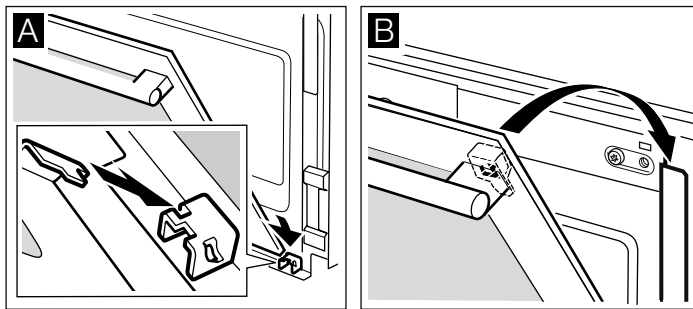

Caution!

Make sure that the door panel is sitting flush with the control panel.

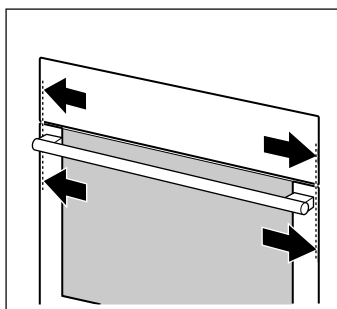

3. Fully open the door, while holding the panels firmly with one hand (Fig. C).
4. Push the door downwards again and tighten the screws hand-tight using a TORX screwdriver (TORX 20) and close the door. (Fig. D).

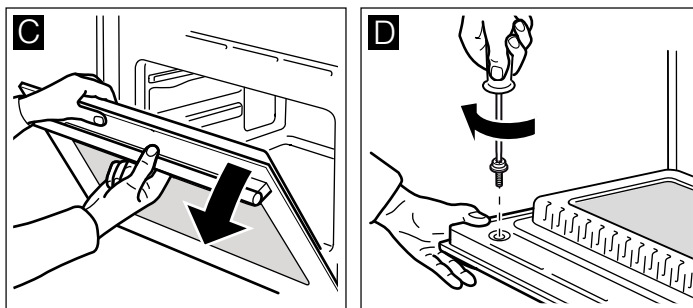

Caution!

You must not use the oven again until the panels have been properly refitted.

Faults and repairs





It is not always necessary to call the after-sales service. Sometimes, you can find a remedy yourself. You will find some tips for troubleshooting in the following table.

⚠ Risk of electric shock!





Malfunction table

If a meal doesn't turn out as well as you had hoped, refer to the section *Tested for you in our cooking studio*, where you will find plenty of cooking tips and tricks.

- Work on the appliance electronics may only be performed by a specialist.
- Always disconnect the appliance from the power supply when work is carried out on the electronics. Switch off the circuit breaker or remove the fuse from your household fuse box.

Problem	Possible cause	Remedy/information
The appliance does not work.	The plug is not plugged into the mains.	Plug in the plug.
	Power cut	Check whether the kitchen light works.
	Defective fuse	Look in the fuse box to make sure that the fuse for the appliance is OK.
	Malfunction.	Switch off the circuit-breaker for the appliance in the fuse box, then switch it back on after approximately 10 seconds.
The two dots and three zeros flash in the display.	Power cut	Reset the clock.
The microwave does not switch on.	The door was not fully closed.	Check whether food remains or foreign material is trapped in the door.
	The  button has not been pressed.	Press the  button.
The appliance does not heat up to the temperature which has been set.	The  button was not pressed.	Press the  button.
Microwave operation has been cancelled for no apparent reason.	The microwave has a fault.	If this fault occurs repeatedly, please call the after-sales service. Oven operation without microwave is possible.
With microwave operation, the food takes longer to heat up than before.	The microwave power setting was too low.	Select a higher microwave power setting.
	You have placed a larger amount of food than normal in the appliance.	Double the amount = almost double the time.
	The food was colder than usual.	Stir or turn the food during cooking
The oven does not heat up. “  ” appears in the temperature display	The demo setting is activated. “Demo setting activated” appears in the text display.	Switch off the circuit breaker in the fuse box and switch it on again after approximately 20 seconds.
“000” appears in the temperature display.	Automatic switch-off has been activated. The oven stops heating.	Press a button or switch off the appliance.

Error messages with E

If an error message beginning with the letter E appears on the display, press the clock function button  repeatedly until the / /  and  symbols appear. Then reset the clock. If the error is shown again, call the after-sales service.

Risk of electric shock!

- Incorrect repairs are dangerous. Repairs may only be carried out and damaged power cables replaced by one of our trained after-sales technicians.
- If the appliance is faulty, switch off the circuit breaker in the fuse box or disconnect the appliance at the mains. Call the after-sales service.

You can take remedial action yourself for some error messages.

Problem	Possible cause	Remedy/information
The error message “E101” or “E104” appears in the clock display.	The temperature sensor has failed.	Call the after-sales service. Microwave operation is possible on its own.
The “E011” error message is shown in the display.	A button was pressed for too long or has jammed.	Press all buttons individually. If the error message remains, please contact the after-sales service.
The error message “E010”, “E310”, “E009” or “E309” appears in the display.	Technical malfunction.	Call the after-sales service.

Replacing the oven light bulb

It is possible to replace the oven light. Heat-resistant 12 V, 20 W halogen bulbs can be obtained from After-sales Service or a specialist retailer.

Risk of electric shock!

Never replace the oven light when the appliance is switched on. Pull out the mains plug or switch off the appliance at the circuit breaker in the fuse box.

Note: Always remove the new halogen bulb from the packaging using a dry cloth. This increases the service life of the bulb.

Method

1. Switch off the circuit breaker in the fuse box.
2. Place a tea towel in the cold oven to prevent damage.

3. Remove the glass cover. To do this, open the glass cover at the bottom with your hand. Should you experience difficulties removing the glass cover, use a spoon to help. (Fig. A).

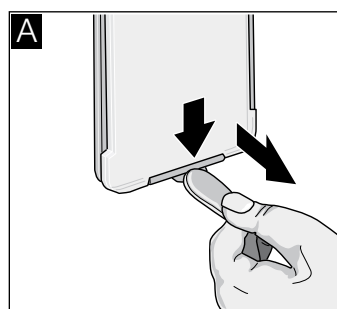

4. Remove the bulb and replace with a bulb of the same type. (Fig. B).

5. Refit the glass cover. (Fig. C).

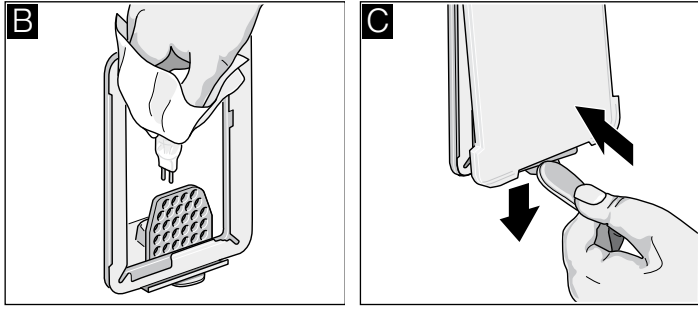

6. Remove the tea towel.

7. Switch the circuit breaker in the fuse box back on or plug in the mains plug.

Replacing the door seal

If the door seal is defective, it must be replaced. Replacement seals for your appliance can be obtained from the after-sales service. Please supply your appliance's E number and FD number.

Risk of serious damage to health.!

Never use the appliance if the door seal is damaged. Microwave energy may escape. Do not use the appliance again until it has been repaired.

1. Open the oven door.
2. Remove the old door seal.
3. There are 5 hooks attached to the door seal. Use these hooks to attach the new seal to the oven door.

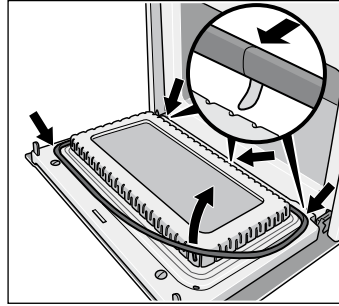

Note: The presence of the join at the bottom of the door seal in the centre is technically required.

After-sales service

Our after-sales service is there for you if your appliance needs to be repaired. We will always find the right solution in order to avoid unnecessary visits from a service technician.

E number and FD number

When calling us, please give the product number (E no.) and the production number (FD no.) so that we can provide you with the correct advice. The rating plate bearing these numbers can be found in the oven. You can make a note of the number of your appliance and the telephone number of the after-sales service in the space below to save time should it be required.

E no. FD no.

After-sales service 

Please note that there will be a fee for a visit by a service technician in the event of a malfunction, even during the warranty period.

Please find the contact data of all countries in the enclosed customer service list.

To book an engineer visit and product advice

GB 0844 8928989
Calls from a BT landline will be charged at up to 3 pence per minute. A call set-up fee of up to 6 pence may apply.

IE 01450 2655
0.03 € per minute at peak. Off peak 0.0088 € per minute.

Rely on the professionalism of the manufacturer. You can therefore be sure that the repair is carried out by trained service technicians who carry original spare parts for your appliances.

This appliance corresponds to the standards EN 55011 and CISPR 11. It is a Group 2, Class B product.

Group 2 means that microwaves are produced for the purpose of heating food. Class B states that the appliance is suitable for private households.

Energy and environment tips

Here you can find tips on how to save energy when baking and roasting and how to dispose of your appliance properly.

Saving energy

Only preheat the oven if this is specified in the recipe or in the operating instruction tables.

Use dark, black lacquered or enamelled baking tins. They absorb the heat particularly well.

Open the appliance door as little as possible during cooking, baking or roasting.

It is best to bake several cakes one after the other. The cooking compartment is still warm. This may reduce the baking time for the second cake.

For longer cooking times, you can switch the oven off 10 minutes before the end of the cooking time and use the residual heat to finish cooking.

Environmentally-friendly disposal

Dispose of packaging in an environmentally-friendly manner.



This appliance is labelled in accordance with European Directive 2012/19/EU concerning used electrical and electronic appliances (waste electrical and electronic equipment - WEEE). The guideline determines the framework for the return and recycling of used appliances as applicable throughout the EU.

Automatic programmes

The automatic programmes enable you to prepare food very easily. You select the programme and enter the weight of your food. The automatic programme makes the optimum setting.

Ovenware

The automatic programmes are only intended for roasting in ovenware with a lid. For all programmes, use deep ovenware with lid. Place the ovenware on the wire rack at level 1.

Suitable cookware

Heat-resistant (up to 300 °C) glass or glass ceramic ovenware, for example, is suitable.

Unsuitable cookware

Cookware made of unglazed clay and plastic cookware or cookware with plastic handles is not suitable.

Metal cookware is not suitable.

The microwave is used for some programmes. Metal does not allow microwaves to pass through. The food will not brown as much and the meat will not be as well cooked.

Size of the ovenware

The meat should cover about two thirds of the ovenware base. This will ensure that you get good meat juices.

The distance between the meat and the lid must be at least 3 cm. The meat may expand during the roasting process.

Selecting a programme

Example in picture:
selecting and setting the programme for 0.30 kg of polenta.

1. Pop out the operating mode selector.
The appliance is ready for operation.
2. Press the **P** button.
The first programme group appears.

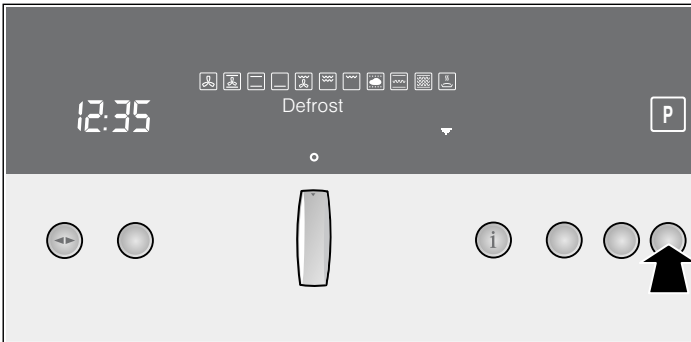

3. Select the desired programme group using the operating mode selector.

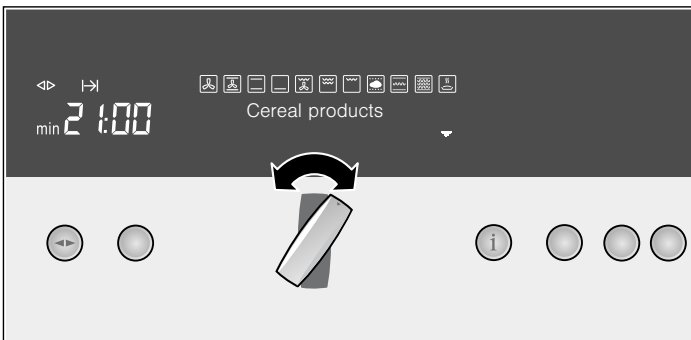

4. Press the **↓** button.
The first programme in the programme group appears on the text display.

5. Turn the operating mode selector until the matching programme appears.

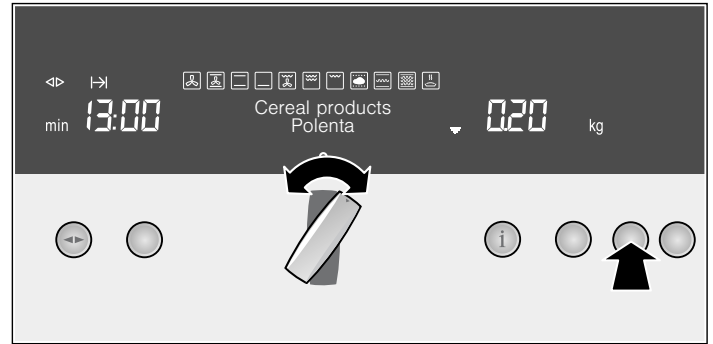

6. Using the temperature selector, set the weight of the food.
The program length **13:00** is shown on the clock display.

7. Press the **Start** button.

The programme starts.

Note: After starting: press the **i** button once. The set values are shown on the displays.

The programme has ended

A signal sounds. The oven stops heating. Use the operating mode selector to switch off the oven or select a new operating mode and make the settings.

Cancelling the programme

Switch off the oven using the **Stop** button, turn the operating mode selector to the **O** position and push in.

Calling up information

Before starting: Press the button **i** briefly. Various information on the programmes is displayed. For each item of information, press the **i** button again briefly.

Setting a later end time

See the section *Electronic clock*.

Adjusting individually

If the cooking result of a programme does not meet your expectations, you can change it the next time.

Make the settings as described in steps 1 to 5.

Press the **↑** button and use the operating mode selector to move the illuminated square.

- □□□■□□□ +

To the left = cooking result less well done.

To the right = cooking result more well done.

Start with the **Start** button.

The cooking time changes.

Defrosting and cooking with the automatic programmes

Notes

- Take the food out of its packaging and weigh it. If it is not possible to enter the exact weight, you should round it up or down.
- Always use microwaveable ovenware, e.g. made of glass, ceramic or the universal pan. Observe the accessories tips in the programme table.
- Place the food in the cold cooking compartment.
- A table of suitable types of food with appropriate weight ranges and the accessories required can be found in the section after the tips.

- It is not possible to set a weight outside the weight range.
- With many dishes, a signal sounds after a certain time. Turn or stir the food.

Defrost

Notes

- If possible, freeze and store food flat and in portions at -18 °C.
- Put the frozen food on shallow tableware, e.g. a glass or porcelain plate. Place bread rolls directly on the wire rack.
- Cover thin and protruding parts with small pieces of aluminium foil. This prevents these parts from cooking prematurely. Ensure that the aluminium foil does not touch the walls of the cooking compartment.
- After defrosting, allow the food to defrost for a further 10 to 90 minutes so that it acquires an even temperature.

- Liquid will be produced when defrosting meat, poultry or fish. Drain off this liquid when you turn the food. Under no circumstances should it be used for other purposes or be allowed to come into contact with other foods.
- Place beef, lamb and pork on the ovenware fatty-side down first.
- Bread should only be defrosted in the required amounts, as it quickly becomes stale.
- After turning, remove any minced meat that has already defrosted.
- Whole poultry should be placed in the ovenware breast-side down and poultry portions skin-side down. Cover legs and wings with small pieces of aluminium foil.
- For whole fish, cover the tail with aluminium foil, for fish fillets cover the edges and for fish steaks cover the protruding ends.

Programme group Programme	Suitable food	Weight range in kg	Ovenware/accessories, shelf height
Defrost			
Wheat bread		0.10 - 0.60	Shallow ovenware without lid, wire rack, level 1
Wholemeal bread***		0.20 - 1.50	Shallow ovenware without lid, wire rack, level 1
Bread rolls		0.05 - 0.45	Wire rack, level 1
Cakes, dry*	Sponge cake without glaze or icing, plaited yeast cake	0.20 - 1.50	Shallow ovenware without lid, wire rack, level 1
Cake, moist	Sponge cake with fruit without icing, glaze or gelatine, with no crème pâtissière or cream	0.20 - 1.20	Shallow ovenware without lid, wire rack, level 1
Minced meat*	Minced beef, lamb, or pork	0.20 - 1.00	Shallow ovenware without lid, wire rack, level 1
Beef**	Joint of beef, joint of veal, steak	0.20 - 2.00	Shallow ovenware without lid, wire rack, level 1
Pork**	Boned pork neck joint, rolled roasting joint, schnitzel, goulash	0.20 - 2.00	Shallow ovenware without lid, wire rack, level 1
Lamb**	Leg of lamb, lamb shoulder, rolled roasting joint of lamb	0.20 - 2.00	Shallow ovenware without lid, wire rack, level 1
Whole poultry**	Chicken, duck	0.70 - 2.00	Shallow ovenware without lid, wire rack, level 1
Poultry portions**	Chicken thigh, half chicken, leg of goose, goose breast, duck breast	0.20 - 1.20	Shallow ovenware without lid, wire rack, level 1
Whole fish**	Trout, haddock, cod	0.20 - 1.20	Shallow ovenware without lid, wire rack, level 1
Fish fillet**	Fillet of pike, cod, salmon, rosefish, pollock, pike-perch	0.20 - 1.00	Shallow ovenware without lid, wire rack, level 1
Fish steak**	Cod, pike, haddock, salmon steak	0.20 - 1.00	Shallow ovenware without lid, wire rack, level 1

* Signal to turn after the cooking time is approximately halfway through.

** Signal to turn after $\frac{1}{3}$ and $\frac{2}{3}$ of the cooking time has elapsed.

***Signal to turn after $\frac{2}{3}$ of the cooking time has elapsed.

Cooking

Vegetables

Notes

- Fresh vegetables: cut into pieces of equal size. Add 2 tablespoons of water for every 100 g of vegetables.
- Frozen vegetables: this programme is only suitable for blanched, not pre-cooked vegetables. It is not suitable for fro-

zen vegetables in cream sauce. Add 1 to 2 tablespoons of water per 100 g. Do not add water to spinach or red cabbage.

- After the programme has ended, leave the vegetables to stand for approx. a further 5 minutes.

Programme group Programme	Suitable food	Weight range in kg	Ovenware/accessories, shelf height
Vegetables			
Cook fresh vegetables*	Cauliflower, broccoli, carrots, kohlrabi, leeks, peppers, courgettes	0.20 - 1.00	Ovenware with lid, wire rack, level 1
Cook frozen vegetables*	Cauliflower, broccoli, carrots, kohlrabi, red cabbage, spinach	0.20 - 1.00	Ovenware with lid, wire rack, level 1

* Signal to stir halfway through the cooking time.

Potatoes

Notes

- Boiled potatoes: cut into pieces of equal size. Add 2 tablespoons of water per 100 g of potatoes, and salt to taste.
- Unpeeled boiled potatoes: use potatoes of the same size. Wash the potatoes and prick the skin several times. Place them in ovenware while still wet. Do not add water.
- After the programme has ended, leave the potatoes to stand for approx. a further 5 minutes. Strain away the remaining water beforehand.
- For potato gratin, layer the potatoes in shallow ovenware 3 to 4 cm deep.
- After the programme has ended, leave the bake to stand in the appliance for an additional 5 to 10 minutes.
- Chips, croquettes and röstis must be suitable for preparation in the oven.

Programme group Programme	Suitable food	Weight range in kg	Ovenware/accessories, shelf height
Potatoes			
Boiled potatoes*	Waxy potatoes, quite waxy potatoes, floury potatoes	0.20 - 1.00	Ovenware with lid, wire rack, level 1
Unpeeled boiled potatoes*	Waxy potatoes, quite waxy potatoes, floury potatoes	0.20 - 1.00	Ovenware with lid, wire rack, level 1
Potato gratin, fresh		0.50 - 3.00	Shallow ovenware without lid, wire rack, level 2
Chips, frozen**		0.20 - 0.60	Universal pan, level 2
Croquettes, frozen**		0.20 - 0.70	Universal pan, level 2
Röstis, frozen**		0.20 - 0.80	Universal pan, level 2

* Signal to stir halfway through the cooking time.

** Signal to turn after $\frac{2}{3}$ of the cooking time has elapsed.

Cereal products

Notes

- Cereal products foam a lot during cooking. Therefore, use a deep dish with a lid for all cereal products. Enter the weight of the uncooked cereal product (without liquid).
- Rice: Do not use boil-in-the-bag rice. Add two to two and a half times the amount of liquid to the rice.
- Polenta: For polenta, add two to three times the amount of water depending on the degree of grinding.
- Couscous: Add two times the amount of liquid.
- Millet: Add two to two and a half times the amount of liquid.
- After the programme has ended, leave the cereal to stand for approx. a further 5 to 10 minutes.

Programme group Programme	Weight range in kg	Ovenware/accessories, shelf height
Cereal products		
Long grain rice*	0.10 - 0.50	Deep ovenware with lid, wire rack, level 1
Basmati rice*	0.10 - 0.50	Deep ovenware with lid, wire rack, level 1
Brown rice*	0.10 - 0.50	Deep ovenware with lid, wire rack, level 1
Polenta***	0.10 - 0.50	Deep ovenware with lid, wire rack, level 1
Couscous**	0.10 - 0.50	Deep ovenware with lid, wire rack, level 1
Millet*	0.10 - 0.50	Deep ovenware with lid, wire rack, level 1

* Signal to stir after approx. 2 - 14 minutes depending on weight.

** Signal to stir after 1-2 minutes.

*** Signal to stir halfway through the cooking time.

Bake

Notes

- Place the meal in microwaveable ovenware on the wire rack.
- Layer sweet and savoury bakes in shallow ovenware approx. 5 cm deep.
- For potato gratin, layer the potatoes in shallow ovenware 3 to 4 cm deep.
- After the programme has ended, leave the potato gratin to stand in the appliance for an additional 5 to 10 minutes.

Programme group Programme	Weight range in kg	Ovenware/accessories, shelf height
Bake		
Lasagne bolognese, frozen	0.40 - 1.00	Ovenware without lid, wire rack, level 1
Cannelloni, frozen	0.40 - 1.00	Ovenware without lid, wire rack, level 1

Programme group Programme	Weight range in kg	Ovenware/accessories, shelf height
Macaroni bake, frozen	0.40 - 1.00	Ovenware without lid, wire rack, level 1
Bake, savoury, cooked ingredients	0.40 - 3.00	Shallow ovenware without lid, wire rack, level 2
Bake, sweet	0.50 - 1.80	Shallow ovenware without lid, wire rack, level 1
Potato gratin, fresh	0.50 - 3.00	Shallow ovenware without lid, wire rack, level 2

Frozen products

Notes

- Use prebaked, frozen pizza and pizza baguettes.
- Chips, croquettes and röstis must be suitable for preparation in the oven.
- Spring rolls and mini spring rolls must be suitable for preparation in the oven.
- Make sure that frozen food is placed in a single layer.

Programme group Programme	Weight range in kg	Ovenware/accessories, shelf height
Pizza, thin base	0.30 - 0.50	Universal pan, level 1
Pizza, deep-pan	0.40 - 0.60	Universal pan, level 1
Mini pizza	0.10 - 0.60	Universal pan, level 1
Pizza baguettes, prebaked	0.10 - 0.75	Universal pan, level 1
Chips*	0.20 - 0.60	Universal pan, level 2
Croquettes*	0.20 - 0.70	Universal pan, level 2
Röstis*	0.20 - 0.80	Universal pan, level 2
Lasagne bolognese	0.40 - 1.00	Ovenware without lid wire rack, level 1
Cannelloni	0.40 - 1.00	Ovenware without lid wire rack, level 1
Macaroni bake	0.40 - 1.00	Ovenware without lid wire rack, level 1
Spring rolls**	0.10 - 1.00	Universal pan, level 2
Mini spring rolls**	0.10 - 0.60	Universal pan, level 2
Fish fingers*	0.20 - 0.90	Universal pan, level 2
Breaded squid rings*	0.20 - 0.50	Universal pan, level 2

* Signal to turn after $\frac{2}{3}$ of the cooking time has elapsed.

** Signal to turn after the cooking time is halfway through.

Poultry

Notes

- Place chicken or poulard in the ovenware breast-side down.
- Place chicken portions in the ovenware skin-side up.
- Cook turkey breast without the skin. Add 100 to 150 ml of liquid to the turkey breast. Add another 50 to 100 ml of liquid after turning if necessary.
- After the programme has ended, leave the turkey breast to stand for a further 10 minutes.

Programme group Programme	Suitable food	Weight range in kg	Ovenware/accessories, shelf height
Poultry			
Chicken, fresh*	Whole chicken	0.80 - 1.80	Deep ovenware with lid, wire rack, level 1
Chicken portions, fresh	Chicken thigh, half chicken	0.40 - 1.20	Deep ovenware with lid, wire rack, level 1
Poulard, fresh*		1.50 - 3.00	Deep ovenware with lid, wire rack, level 1
Turkey breast, fresh**	Skinless turkey breast	0.80 - 2.00	Deep ovenware with lid, wire rack, level 1

* Signal to turn whole chicken after $\frac{2}{3}$ of the cooking time has elapsed.

** Signal to turn after the cooking time is halfway through.

Meat

Notes

- Cook sirloin fatty-side down first.
- Joint of beef, joint of veal, knuckle of veal, leg of lamb and joint of pork:
The joint should cover two thirds of the ovenware base. Add 50 to 100 ml of liquid to the roast. Add another 50 to 100 ml of liquid after turning if necessary.
- Add 50 to 100 ml of liquid to the meat loaf.
- After the programme has ended, leave the roast to stand for another 10 minutes.

Programme group Programme	Suitable food	Weight range in kg	Ovenware/accessories, shelf height
Beef			
Pot roast, fresh**		0.80 - 2.00	Deep ovenware with lid, wire rack, level 1
Sirloin, medium*	Thick piece of sirloin, 5 - 6 cm	0.80 - 2.00	Ovenware without lid, wire rack, level 1
Sirloin, rare*	Thick piece of sirloin, 5 - 6 cm	0.80 - 2.00	Ovenware without lid, wire rack, level 1
Meat loaf	approx. 8 cm deep	0.80 - 1.50	Ovenware with lid, wire rack, level 1
Roulades		0.50 - 3.00	Deep ovenware with lid, wire rack, level 1
Veal			
Joint, fresh*	Rump, flank	0.80 - 2.00	Ovenware with lid, wire rack, level 1
Knuckle on the bone, fresh		0.80 - 3.00	Ovenware with lid, wire rack, level 1
Osso buco		0.80 - 3.00	Ovenware with lid, wire rack, level 1
Pork			
Pork neck joint, fresh, boned***		0.80 - 2.00	Ovenware with lid, wire rack, level 1
Neck joint, fresh, on the bone*		0.80 - 2.50	Ovenware with lid, wire rack, level 1
Joint with crust, fresh		0.80 - 2.00	Ovenware with lid, wire rack, level 1
Meat loaf	approx. 8 cm deep	0.80 - 1.50	Ovenware with lid, wire rack, level 1
Rolled roasting joint, fresh*		1.00 - 3.00	Ovenware with lid, wire rack, level 1
Lamb			
Leg, fresh, boned, medium*		0.80 - 2.00	Ovenware with lid, wire rack, level 1
Leg, fresh, on the bone, well-done*		0.80 - 2.00	Ovenware with lid, wire rack, level 1
Meat loaf	approx. 8 cm deep	0.80 - 1.50	Ovenware with lid, wire rack, level 1
Game			
Joint of venison, fresh*		0.50 - 3.00	Deep ovenware with lid, wire rack, level 1
Leg of roe venison, boned, fresh***		0.50 - 2.50	Deep ovenware with lid, wire rack, level 1
Haunch of hare, on the bone, fresh***		0.50 - 1.50	Deep ovenware with lid, wire rack, level 1
Wild boar joint, fresh***		0.50 - 2.50	Deep ovenware with lid, wire rack, level 1
Rabbit, fresh		0.50 - 2.00	Deep ovenware with lid, wire rack, level 1

* Signal to turn after the cooking time is halfway through

** Signal to turn after $\frac{1}{3}$ and $\frac{2}{3}$ of the cooking time has elapsed.

***Signal to turn after $\frac{2}{3}$ of the cooking time has elapsed.

Fish

Notes

- Whole fish, fresh:

Add 1 to 3 tablespoons of water or lemon juice.

Fish fillet, fresh

Add 1 to 3 tablespoons of water or lemon juice.

- Breaded squid rings, frozen:

They must be suitable for cooking in the oven.

Programme group Programme	Weight range in kg	Ovenware/accessories, shelf height
Braise whole fresh fish	0.30 - 1.10	Ovenware with lid, wire rack, level 1
Steam fresh fish fillet	0.20 - 1.00	Ovenware with lid, wire rack, level 1
Fish fingers*	0.20 - 0.90	Universal pan, level 2
Squid rings, frozen*	0.20 - 0.50	Universal pan, level 2

* Signal to turn after $\frac{2}{3}$ of the cooking time has elapsed.

Meat loaf and stew

Note: Add 50 to 100 ml of liquid to the meat loaf.

Programme group Programme	Suitable food	Weight range in kg	Ovenware/accessories, shelf height
Meat loaf			
Made from fresh beef	approx. 8 cm deep	0.80 - 1.50	Ovenware with lid, wire rack, level 1
Made from fresh pork	approx. 8 cm deep	0.80 - 1.50	Ovenware with lid, wire rack, level 1

* Set the weight of the meat

Programme group Programme	Suitable food	Weight range in kg	Ovenware/accessories, shelf height
Made from fresh, mixed meat	approx. 8 cm deep	0.80 - 1.50	Ovenware with lid, wire rack, level 1
Made from fresh lamb	approx. 8 cm deep	0.80 - 1.50	Ovenware with lid, wire rack, level 1
Stew*			
Goulash		0.30 - 2.00	Deep ovenware with lid, wire rack, level 1
Roulades		0.50 - 3.00	Deep ovenware with lid, wire rack, level 1

* Set the weight of the meat

Tested for you in our cooking studio

You will find a selection of dishes and the ideal settings for them. We will show you which type of heating and which temperature or microwave power setting is best for your meal. You can find information about suitable accessories and the height at which they should be inserted. There are also tips about cookware and preparation methods.

Notes

- The values in the table always apply to food placed in the cooking compartment when it is cold and empty. Only preheat the appliance if the table specifies that you should do so. Before using the appliance, remove all accessories from the cooking compartment that you will not be using.
- Do not line the accessories with greaseproof paper until after they have been preheated.
- The times specified in the tables are only guidelines. They will depend on the quality and composition of the food.
- Use the accessories provided. Additional accessories may be obtained as optional accessories from specialist retailers or from the after-sales service.
- Always use an oven cloth or oven gloves when taking hot accessories or cookware out of the cooking compartment.
- When using the microwave solo, i.e. on its own without any type of heating, always use the wire rack at level 1.

Defrosting, heating up and cooking with the microwave

The following tables provide you with numerous options and settings for the microwave.

Defrost	Weight	Microwave power setting in watts, cooking time in minutes	Notes
Whole pieces of beef, veal or pork (on the bone or boned)	800 g	180 W, 15 mins + 90 W, 10-15 mins	Turn several times
	1 kg	180 W, 15 mins + 90 W, 20-30 mins	
	1.5 kg	180 W, 25 mins + 90 W, 25-35 mins	
Meat in pieces or slices of beef, veal or pork	200 g	180 W, 5 mins + 90 W, 4-6 mins	Separate any defrosted parts when turning
	500 g	180 W, 8 mins + 90 W, 5-10 mins	
	800 g	180 W, 10 mins + 90 W, 10-15 mins	
Minced meat, mixed	200 g	90 W, 8-15 mins	Turn several times, remove any defrosted meat
	500 g	180 W, 5 mins + 90 W, 10-15 mins	
	800 g	180 W, 10 mins + 90 W, 15-20 mins	
	1 kg	180 W, 10 mins + 90 W, 20-25 mins	
Poultry or poultry portions	600 g	180 W, 5 mins + 90 W, 13-18 mins	Turn during cooking.
	1.2 kg	180 W, 10 mins + 90 W, 10-15 mins	
Duck	2 kg	180 W, 10 mins + 90 W, 30-40 mins	Turn several times
Goose	4.5 kg	180 W, 20 mins + 90 W, 60-80 mins	Turn every 20 minutes, remove liquid that escapes during defrosting
Fish fillet, fish steak or slices	400 g	180 W, 5 mins + 90 W, 10-15 mins	Separate any defrosted parts.

The times specified in the tables are only guidelines. They may vary according to the ovenware used, the quality, temperature and consistency of the food.

Time ranges are often specified in the tables. Set the shortest time first and then extend the time if necessary.

It may be that you have different quantities from those specified in the tables. A rule of thumb can be applied:

Double the amount - almost twice the cooking time,
Half the amount - half the cooking time.

Insert the wire rack at level 1. Place the ovenware in the centre. The food will then absorb the microwaves from all sides.

Defrosting

Notes

- Place the frozen food in an open container on the wire rack.
- Delicate parts such as the legs and wings of chicken or fatty outer layers of roasts can be covered with small pieces of aluminium foil. The foil must not touch the cooking compartment walls. You can remove the foil half way through the defrosting time.
- Turn or stir the food once or twice during the defrosting time. Large pieces of food should be turned several times. When turning, remove any liquid that has resulted from defrosting.
- Leave defrosted items to stand at room temperature for a further 10 to 60 minutes so that the temperature can stabilise. The giblets can be removed from poultry at this point.

Defrost	Weight	Microwave power setting in watts, cooking time in minutes	Notes
Whole fish	300 g	180 W, 3 mins + 90 W, 10-15 mins	Turn during cooking.
	600 g	180 W, 8 mins + 90 W, 10-15 mins	
Vegetables, e.g. peas	300 g	180 W, 5-15 mins	Stir carefully during defrosting.
	600 g	180 W, 10 mins + 90 W, 8-13 mins	
Fruit, e.g. raspberries	300 g	180 W, 5-10 mins	Stir carefully during defrosting and separate any defrosted parts.
	500 g	180 W, 8 mins + 90 W, 5-10 mins	
Butter, defrosting	125 g	90 W, 7-9 mins	Remove all packaging.
	250 g	180 W, 2 mins + 90 W, 3-5 mins	
Loaf of bread	500 g	180 W, 3 mins + 90 W, 10-15 mins	Turn during cooking.
	1 kg	180 W, 3 mins + 90 W, 15-25 mins	
Cakes, dry, e.g. sponge cake	500 g	90 W, 10-15 mins	Only for cakes without icing, cream or crème pâtissière, separate the pieces of cake.
	750 g	180 W, 2 mins + 90 W, 10-15 mins	
Cakes, moist, e.g. fruit flan, cheesecake	500 g	180 W, 5 mins + 90 W, 15-20 mins	Only for cakes without icing, cream or crème pâtissière
	750 g	180 W, 10 mins + 90 W, 15-20 mins	

Defrosting, heating up or cooking frozen food

Notes

- Take ready meals out of the packaging. They will heat up more quickly and evenly in microwaveable ovenware. The different components of the meal may not require the same amount of time to heat up.
- Food which lies flat will cook more quickly than food which is piled high. You should therefore distribute the food so that it is as flat as possible in the ovenware. Different foodstuffs should not be placed in layers on top of one another.

- Always cover the food. If you do not have a suitable cover for your ovenware, use a plate or special microwave foil.
- Stir or turn the food 2 or 3 times during cooking.
- After heating, allow the food to stand for a further 2 to 5 minutes so that it can achieve an even temperature.
- Always use an oven cloth or oven gloves when removing plates from the oven.
- This will help the food retain its own distinct taste, so it will require less seasoning.

Defrosting, heating up or cooking frozen food	Weight	Microwave power setting in watts, cooking time in minutes	Notes
Menu, plated meal, ready meal	300-400 g	600 W, 11-15 mins	Take meal out of packaging; cover food before heating
Soup	400-500 g	600 W, 8-13 mins	Ovenware with lid
Stew	500 g	600 W, 10-15 mins	Ovenware with lid
	1 kg	600 W, 20-25 mins	
Slices or pieces of meat in sauce, e.g. goulash	500 g	600 W, 12-17 mins	Ovenware with lid
	1 kg	600 W, 25-30 mins	
Fish, e.g. fillets	400 g	600 W, 10-15 mins	Covered
	800 g	600 W, 18-23 mins	
Side dishes, e.g. rice, pasta	250 g	600 W, 2-5 mins	Ovenware with lid; add liquid
	500 g	600 W, 7-10 mins	
Vegetables, e.g. peas, broccoli, carrots	300 g	600 W, 8-12 mins	Ovenware with lid; add 1 tbsp of water
	600 g	600 W, 13-18 mins	
Creamed spinach	450 g	600 W, 11-16 mins	Cook without additional water

Heating food

Risk of scalding!

There is a possibility of delayed boiling when a liquid is heated. This means that the liquid reaches boiling temperature without the usual steam bubbles rising to the surface. Even if the container only moves a little, the hot liquid can suddenly boil over and spatter. When heating liquids, always place a spoon in the container. This will prevent delayed boiling.

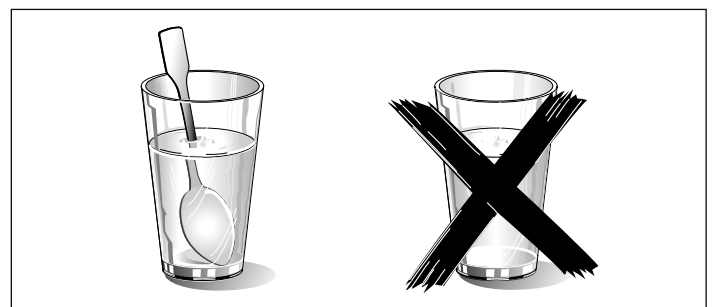

Caution!

Metal - e.g. a spoon in a glass - must be kept at least 2 cm from the oven walls and the inside of the door. Sparks could irreparably damage the glass on the inside of the door.

Notes

- Take ready meals out of the packaging. They will heat up more quickly and evenly in microwaveable ovenware. The different components of the meal may not require the same amount of time to heat up.
- Always cover the food. If you do not have a suitable cover for your container, use a plate or special microwave foil.

- Stir or turn the food several times during the heating time. Check the temperature.
- After heating, allow the food to stand for a further 2 to 5 minutes so that it can achieve an even temperature.
- Always use an oven cloth or oven gloves when removing plates from the oven.

Heating food	Weight	Microwave power setting in watts, cooking time in minutes	Notes
Menu, plated meal, ready meal	350-500 g	600 W, 4-8 mins	Take meal out of packaging, cover food before heating
Drinks	150 ml	1000 W, 1-3 mins	Caution! Place a spoon in the glass. Do not overheat alcoholic drinks. Check during heating
	300 ml	1000 W, 3-4 mins	
	500 ml	1000 W, 4-5 mins	
Baby food, e.g. baby bottle	50 ml	360 W, ½-1 min	Place baby bottles on the cooking compartment floor without the teat or lid. Shake or stir well after heating. You must check the temperature
	100 ml	360 W, 1-1½ mins	
	200 ml	360 W, 1-2 mins	
Soup 1 cup	175 g	1000 W, 1½-2 mins	-
Soup 2 cups	175 g each	1000 W, 2-4 mins	
Soup 4 cups	175 g each	1000 W, 4-6 mins	
Slices or pieces of meat in sauce, e.g. goulash	500 g	600 W, 7-10 mins	Covered
Stew	400 g	600 W, 5-7 mins	Ovenware with lid
	800 g	600 W, 7-10 mins	
Vegetables	150 g	600 W, 2-3 mins	Add a little liquid
	300 g	600 W, 3-5 mins	

Cooking food

Notes

- Food which lies flat will cook more quickly than food which is piled high. You should therefore distribute the food so that it is as flat as possible in the ovenware. Different foodstuffs should not be placed in layers on top of one another.
- Cook the food in ovenware with a lid. If you do not have a suitable lid for your ovenware, use a plate or special microwave foil.

- This will help the food retain its own distinct taste, so it will require less seasoning.
- After cooking, allow the food to stand for a further 2 to 5 minutes so that it can achieve an even temperature.
- Always use an oven cloth or oven gloves when removing plates from the oven.

Cooking food	Weight	Microwave power in watts, Cooking time in minutes	Notes
Whole chicken, fresh, no giblets	1.5 kg	600 W, 25-30 mins	Turn halfway through the cooking time
Fish fillet, fresh	400 g	600 W, 8-13 mins	-
Fresh vegetables	250 g	600 W, 6-10 mins	Cut into equal-sized pieces; add 1 to 2 tbsp water per 100 g; stir during cooking
	500 g	600 W, 10-15 mins	
Potatoes	250 g	600 W, 8-11 mins	Cut into equal-sized pieces; add 1 to 2 tbsp water per 100 g; stir during cooking
	500 g	600 W, 12-15 mins	
	750 g	600 W, 15-22 mins	
Rice	125 g	600 W, 4-6 mins+ 180 W, 12-15 mins	Add double the quantity of liquid and use deep ovenware with a lid
	250 g	600 W, 7-9 mins+ 180 W, 15-20 mins	
Sweet foods, e.g. blancmange (instant)	500 ml	600 W, 5-8 mins	Stir 2 to 3 times with an egg whisk while heating
Fruit, compote	500 g	600 W, 9-12 mins	-

Popcorn for the microwave

Notes

- Use heat-resistant, flat glass ovenware, e.g. the lid of an ovenproof dish, a glass plate or a glass tray (Pyrex)
- Always place the ovenware on the wire rack at level 1.
- Do not use porcelain or extremely curved plates.

- Make the settings as described in the table. You can adjust the timings according to product and amount.
- So that the popcorn doesn't burn, briefly take the popcorn bag out of the oven after 1 minute and 30 seconds and shake it. Take care as the bag will be hot!

Risk of scalding!

- Open the popcorn bag carefully as hot steam may be released.

- Never set the microwave to full power.

	Weight	Accessories	Level	Microwave power in watts, Cooking time in minutes
Popcorn for the microwave	1 bag, 100 g	Ovenware, wire rack	1	600 W, 4 mins

Microwave tips

You cannot find any information about the settings for the quantity of food you have prepared.	Increase or reduce the cooking times using the following rule of thumb: Double the amount = almost double the cooking time Half the amount = half the cooking time
The food has become too dry.	Next time, set a shorter cooking time or select a lower microwave power setting. Cover the food and add more liquid.
When the time has elapsed, the food is not defrosted, hot or cooked.	Set a longer time. Large quantities and food which is piled high require longer times.
When the time has elapsed, the food is overheated at the edge but not done in the middle.	Stir it during the cooking time and next time, select a lower microwave power setting and a longer cooking time.
After defrosting, the poultry or meat is defrosted on the outside but not defrosted in the middle.	Next time, select a lower microwave power setting. If you are defrosting a large quantity, turn it several times.

Cakes and pastries

About the tables



Notes













- The times given apply to food placed in a cold oven.
- The temperature and baking time depend on the consistency and amount of the mixture. This is why temperature ranges are given in the tables. Begin with the lower temperature and, if necessary, use a higher setting the next time, since a lower temperature results in more even browning.

- Additional information can be found in the *Baking tips* section following the tables.
- Always place the cake tin in the centre of the wire rack.

Baking tins

Note: It is best to use dark-coloured metal baking tins.

-  Hot air
-  Top/bottom heating

Cakes in tins	Accessories	Level	Type of heating	Temperature °C	Microwave power in watts	Cooking time in minutes
Sponge cake, simple	Ring tin/round tin	1		160-180	90 W	30-40
Sponge cake, delicate (e.g. pound cake)	Ring tin/round tin	1		150-170	-	60-80
Sponge flan base	Flan tin	2		160-180	-	25-35
Delicate fruit flan, sponge	Springform/ring tin	1		160-180	90 W	30-40
Sponge base, 2 eggs	Flan tin	1		150-160	-	20-25
Sponge flan, 6 eggs (preheat)	Dark springform cake tin	1		170-180	-	30-40
Shortcrust pastry base with crust	Dark springform cake tin	1		170-190	-	30-40
Fruit tart/cheesecake with pastry base*	Dark springform cake tin	2		160-170	180 W	30-40
Ring cake	Ring cake tin	1		160-180	90 W	30-40
Nut cake	Dark springform cake tin	1		170-180	90 W	35-45
Pizza, thin base, light topping**	Round pizza tray	1		220-240	-	15-20
Savoury cakes	Dark springform cake tin	1		180-200	-	50-60

* Allow cake to cool in the oven for approx. 20 minutes.

** Preheat the cooking compartment

- □ Top/bottom heating
- ☒ Hot air plus

- ☒ Hot air

Cakes on trays	Accessories	Level	Type of heating	Temperature °C	Microwave power in watts	Cooking time in minutes
Sponge with dry topping	Universal pan	2	□	160-180	-	25-35
Sponge with dry topping	Universal pan + Enamel baking tray*	1 3	☒	150-170	-	40-50
Sponge with moist topping (fruit)	Universal pan	1	☒	160-180	90 W	30-40
Yeast dough with dry topping	Universal pan	2	□	170-190	-	35-45
Yeast dough with dry topping	Universal pan + Enamel baking tray	1 3	☒	160-180	-	50-60
Yeast dough with moist topping (fruit)	Universal pan	2	□	170-190	-	45-55
Yeast dough with moist topping (fruit)	Universal pan + Enamel baking tray*	1 3	☒	160-180	-	50-60
Shortcrust pastry with dry topping	Universal pan	2	□	160-180	-	25-35
Shortcrust pastry with dry topping	Universal pan + Enamel baking tray*	1 3	☒	160-180	-	30-40
Shortcrust pastry with moist topping (fruit)	Universal pan	1	□	160-180	-	50-60
Swiss flan	Universal pan	1	□	190-200	-	40-50
Swiss roll (preheat)	Universal pan	2	□	170-190	-	10-20
Plaited loaf with 500 g flour	Universal pan	2	□	160-180	-	40-50
Stollen with 500 g flour	Universal pan	2	□	150-170	-	60-70
Stollen with 1 kg flour	Universal pan	2	☒	140-150	-	65-75
Strudel, sweet	Universal pan	1	☒	190-210	180 W	30-40
Pizza	Universal pan	1	□	210-230	-	25-35
Pizza	Universal pan + Enamel baking tray*	1 3	☒	190-200	-	40-50

* Enamel baking trays can be obtained as optional accessories from specialist retailers.

- □ Top/bottom heating

- ☒ Hot air plus

Small baked items	Accessories	Level	Type of heating	Temperature in °C	Cooking time in minutes
Biscuits	Universal pan	2	□	150-170	20-30
Biscuits	Universal pan + Enamel baking tray*	1 3	☒	140-160	30-40
Macaroons	Universal pan	2	□	120-140	35-45
Macaroons	Universal pan + Enamel baking tray*	1 3	☒	110-130	40-50
Meringue	Universal pan	2	□	80-100	90-110
Muffins	Muffin tray on wire rack	2	□	160-180	35-45
Muffins	1 muffin tray each on Universal pan + Wire rack	1 3	☒	140-160	50-60
Choux pastry	Universal pan	2	□	200-220	30-40
Puff pastry	Universal pan	2	□	170-190	25-35
Puff pastry	Universal pan + Enamel baking tray*	1 3	☒	170-190	30-40
Leavened cake	Universal pan	2	□	200-220	20-30

* Enamel baking trays can be obtained as optional accessories from specialist retailers.

- □ Top/bottom heating
- ☒ Hot air

Preheat the cooking compartment.

Bread and rolls	Accessories	Level	Type of heating	Temperature in °C	Cooking time in minutes
Yeast bread with 1 kg of flour	Universal pan	2	□	270 + 170	10 15-25
Sourdough bread with 1.2 kg flour	Universal pan	2	□	270 + 170	10 40-50
Flatbread	Universal pan	2	☒	220-240	15-20
Bread rolls	Universal pan	2	□	200-220	20-30
Rolls made with sweet yeast dough	Universal pan	2	□	190-210	15-25

Baking tips

You want to bake according to your own recipe.	Use similar items in the baking tables as a guide.
Use baking tins made of silicone, glass, plastic or ceramic materials.	The baking tin must be heat-resistant up to 250 °C. Cakes in these baking tins will be less brown. When using the microwave, the cooking time will be shorter than the time shown in the table.
How to establish whether sponge cake is baked through.	Approximately 10 minutes before the end of the baking time specified in the recipe, poke the cake with a cocktail stick at its highest point. If the cocktail stick comes out clean, the cake is ready.
The cake collapses.	Use less liquid next time or set the oven temperature 10 degrees lower and extend the baking time. Observe the specified mixing times in the recipe.
The cake has risen in the middle but is lower around the edge.	Only grease the base of the springform cake tin. After baking, loosen the cake carefully with a knife.
The cake is too dark.	Select a lower temperature and bake the cake for a little longer.
The cake is too dry.	When it is done, make small holes in the cake using a toothpick. Then drizzle fruit juice or an alcoholic beverage over it. Next time, select a temperature 10 degrees higher and reduce the baking time.
The bread or cake (e.g. cheesecake) looks good, but is soggy on the inside (sticky, streaked with water).	Use slightly less fluid next time and bake for slightly longer at a lower temperature. When baking cakes with a moist topping, bake the base first, cover with almonds or bread crumbs and then add the topping. Please follow the recipe and follow the baking times.
The cake cannot be turned out of the dish when it is turned upside down.	After baking, allow the cake to cool for a further 5 to 10 minutes, then it will be easier to turn out of the tin. If it still sticks, carefully loosen the cake around the edges using a knife. Turn the cake tin upside down again and cover it several times with a cold, wet cloth. Next time, grease the tin well and sprinkle some bread crumbs into it.
You have measured the temperature of the oven using your own meat thermometer and found there is a discrepancy.	The oven temperature is measured by the manufacturer after a specified period of time using a test rack in the centre of the cooking compartment. Ovenware and accessories affect the temperature measurement, so there will always be some discrepancy when you measure the temperature yourself.
Sparks are generated between the tin and the wire rack.	Check that the tin is clean on the outside. Change the position of the tin in the cooking compartment. If this does not help, continue baking but without the microwave. The baking time will then be longer.

Roasting and grilling

About the tables

The temperature and roasting time depend on the type and amount of food being cooked. This is why temperature ranges are given in the tables. Begin with the lower temperature and, if necessary, use a higher setting the next time,

For more information, see the section entitled *Tips for grilling and roasting* which follows the tables.

Ovenware

You may use any heat-resistant ovenware which is suitable for use in a microwave. Metal roasting dishes are not suitable for roasting with microwaves.

The ovenware can become very hot. Use oven gloves to take the ovenware out of the oven.

Place hot glass ovenware on a dry kitchen towel after they have been removed from the oven. The glass could crack if placed on a cold or wet surface.

Tips for roasting

Use a deep roasting dish for roasting meat and poultry.

Check that your ovenware fits in the cooking compartment. It should not be too big.

Meat:

Cover approx. two thirds of the ovenware base with liquid. Add a little more liquid for pot roasts. Turn pieces of meat halfway through the cooking time. When the roast is ready, turn off the oven and allow it to rest for an additional 10 minutes. This allows better distribution of the meat juices.

Poultry:

Turn the pieces of meat after $\frac{2}{3}$ of the cooking time has elapsed.

Tips for grilling

Notes

- Always keep the oven door closed when grilling and do not preheat.

- As far as possible, the pieces of food you are grilling should be of equal thickness. Steaks should be at least 2 to 3 cm thick. This will allow them to brown evenly and remain succulent and juicy. Do not add salt to steaks until they have been grilled.
- Use tongs to turn the pieces of food you are grilling. If you pierce the meat with a fork, the juices will run out and it will become dry.
- Dark meat, e.g. beef, browns more quickly than lighter-coloured meat such as veal or pork. When grilling light-coloured meat or fish, these often only brown slightly on the surface, although they are cooked and juicy on the inside.
- The grill element switches off and on again automatically. This is normal. The grill setting determines how frequently this will happen.



Tips for braising







Use ovenware with a lid for braising fish.

Add two to three tablespoons of liquid and a little lemon juice or vinegar into the ovenware.

Beef



Notes





- Turn pot-roasted beef after $\frac{1}{3}$ and $\frac{2}{3}$ of the cooking time. Finally, allow to stand for approx. a further 10 minutes.
- Turn fillet of beef and sirloin halfway through the cooking time. Finally, allow to stand for approx. a further 10 minutes.
- Turn steaks after $\frac{2}{3}$ of the cooking time.
-  Top/bottom heating
-  Full-surface grill

Beef	Accessories	Level	Type of heating	Temperature in °C, grill setting	Microwave power in watts	Cooking time in minutes
Pot-roasted beef, approx. 1 kg	Ovenware with lid, wire rack	1		190-210	-	120-140
Pot-roasted beef, approx. 1.5 kg	Ovenware with lid, wire rack	1		180-200	-	140-160
Pot-roasted beef, approx. 2 kg	Ovenware with lid, wire rack	1		170-190	-	160-180
Fillet of beef, medium, approx. 1 kg	Ovenware with lid, wire rack	1		180-200	90 W	30-40
Fillet of beef, medium, approx. 1.5 kg	Ovenware with lid, wire rack	1		200-220	90 W	45-55
Sirloin, medium, approx. 1 kg	Ovenware without lid, wire rack	1		240-260	180 W	30-40
Steaks, medium, 3 cm thick	Universal pan + Wire rack	1 3		3	-	1st side: approx. 10-15 2nd side: approx. 5-10

Veal

Note: Turn joints and knuckle of veal halfway through the cooking time. Finally, allow to stand for approx. a further 10 minutes.



-  Hot air
-  Circo-roasting





Veal	Accessories	Level	Type of heating	Temperature °C	Microwave power in watts	Cooking time in minutes
Joint of veal, approx. 1 kg	Ovenware with lid, wire rack	1		210-220	90 W	60-70
Joint of veal, approx. 1.5 kg	Ovenware with lid, wire rack	1		200-210	90 W	70-80
Joint of veal, approx. 2 kg	Ovenware with lid, wire rack	1		190-200	90 W	80-100
Knuckle of veal, approx. 1.5 kg	Ovenware with lid, wire rack	1		190-200	-	120-130

Pork

Notes

- Turn lean joints of pork and rindless joints halfway through the cooking time. Finally, allow to stand for approx. a further 10 minutes.
- Place the joint in the ovenware rind-side up. Cut into the rind. Do not turn the joint. Finally, allow to stand for approx. a further 10 minutes.

- Do not turn fillet of pork or smoke-cured pork chops. Finally, allow to stand for approx. a further 5 minutes.
- Turn the neck of pork after $\frac{2}{3}$ of the cooking time.
-  Circo-roasting
-  Full-surface grill

Pork	Accessories	Level	Type of heating	Temperature in °C, grill setting	Microwave power in watts	Cooking time in minutes
Joint without rind (e.g. neck), approx. 750 g	Ovenware with lid, wire rack	1		220-240	180 W	40-50
Joint with rind (e.g. shoulder) approx. 1.5 kg	Ovenware without lid, wire rack	1		180-200	-	150
Joint with rind (e.g. shoulder) approx. 2 kg	Ovenware without lid, wire rack	1		170-190	-	180
Fillet of pork, approx. 500 g	Ovenware with lid, wire rack	1		210-230	90 W	20-25

Pork	Accessories	Level	Type of heating	Temperature in °C, grill setting	Microwave power in watts	Cooking time in minutes
Joint of pork, lean, approx. 1 kg	Ovenware with lid, wire rack	1		210-230	90 W	50-60
Joint of pork, lean, approx. 1.5 kg	Ovenware with lid, wire rack	1		200-220	90 W	70-80
Joint of pork, lean, approx. 2 kg	Ovenware with lid, wire rack	1		190-210	180 W, 10 mins + 90 W, 75-85 mins	85-95
Smoked pork on the bone, approx. 1 kg	Ovenware without lid, wire rack	1	-	-	360 W	45-50
Neck of pork 2 cm thick	Universal pan + Wire rack	1 3		2	-	1st side: approx. 15-20 2nd side: approx. 10-15

Lamb and game

Note: Turn lamb and game halfway through the cooking time.

- Circo-roasting
- Top/bottom heating

Lamb and game	Accessories	Level	Type of heating	Temperature °C	Microwave power in watts	Cooking time in minutes
Saddle of lamb on the bone, approx. 1 kg	Ovenware without lid, wire rack	1		190-210	-	40-50
Leg of lamb, boned, medium, approx. 1.5 kg	Ovenware with lid, wire rack	1		180-200	-	90-100
Saddle of venison on the bone, approx. 1 kg	Ovenware with lid, wire rack	1		210-220	-	40-50
Boned leg of roe venison, approx. 1.5 kg	Ovenware with lid, wire rack	1		180-190	-	105-120
Wild boar joint, approx. 1.5 kg	Ovenware with lid, wire rack	1		200-220	-	100-110
Joint of venison, approx. 1.5 kg	Ovenware with lid, wire rack	1		200-220	-	90-100
Rabbit, approx. 1.5 kg	Ovenware with lid, wire rack	1		200-220	90 W	25-35

Miscellaneous

Notes

- Finally, allow the meat loaf to stand for approx. a further 10 minutes.
- Turn the sausages after $\frac{2}{3}$ of the cooking time.

- Circo-roasting
- Full-surface grill















Miscellaneous	Accessories	Level	Type of heating	Temperature in °C, grill setting	Microwave power in watts	Cooking time in minutes
Meat loaf made from approx. 1 kg of meat	Ovenware without lid, wire rack	1		170-190	600 W + 180 W	10 mins + 40-50 mins
4-6 sausages for grilling, approx. 150 g each	Universal pan + rack	1 3		3	-	1st side: approx. 10-15 2nd side: approx. 5-10

Poultry

Notes

- Place whole chickens, chicken breasts and small turkeys breast-side down. Turn after $\frac{2}{3}$ of the cooking time.
- Place poulard breast-side down. Turn after $\frac{2}{3}$ of the cooking time and set the microwave power to 180 watts.
- Place half chickens and chicken portions skin-side up. Do not turn.
- Turn duck and goose after $\frac{1}{3}$ and $\frac{2}{3}$ of the cooking time.
- Place duck and goose breast skin-side down. Turn halfway through the cooking time.
- Turn goose legs halfway through the cooking time. Prick the skin.
- Turn rolled turkey joints after $\frac{2}{3}$ of the cooking time.
- Place turkey breast and thighs skin-side down. Turn after $\frac{2}{3}$ of the cooking time.

- Circo-roasting
- Full-surface grill
- Hot air
- Top/bottom heating



Poultry	Accessories	Level	Type of heating	Temperature in °C, grill setting	Microwave power in watts	Cooking time in minutes
Chicken, whole, approx. 1.2 kg	Ovenware with lid, wire rack	1		230-250	360 W	25-35
Poulard, whole	Ovenware with lid, wire rack	1		200-220	360 W 180 W	30 15-25
Chicken halves, 500 g each	Ovenware without lid, wire rack	1		180-200	360 W	30-35
Chicken portions, approx. 800 g	Ovenware without lid, wire rack	1		190-210	360 W	30-35
Chicken portions, approx. 1.5 kg	Ovenware without lid, wire rack	1		190-210	360 W	35-40
Chicken breast approx. 500 g	Ovenware without lid, wire rack	1		190-210	180 W	25-30
Duck, whole, 1.5 to 1.7 kg	Universal pan	1		170-190	180 W	60-80
Duck breast, whole, 2 pieces, 300 to 400 g each	Wire rack + Universal pan*	2 1		3	90 W	18-22
Goose, whole, 3 to 3.5 kg	Universal pan	1		170-190	180 W	80-90
Goose breast, 2 pieces, 500 g each	Wire rack + Universal pan*	2 1		210-230	90 W	20-25
4 goose legs, approx. 1.5 kg	Wire rack + Universal pan*	2 1		170-190	180 W	30-40
Small turkey, whole, approx. 3 kg	Universal pan	1		170-180	180 W	60-70
Rolled turkey joint, approx. 1.5 kg	Ovenware with lid, wire rack	1		190-200	180 W	60-70
Turkey breast, approx. 1 kg	Ovenware with lid, wire rack	1		200-210	-	80-90
Turkey drumsticks, approx. 1.3 kg	Ovenware with lid, wire rack	1		210-230	360 W	45-50



* Add 50 ml of water to the universal pan.

Fish

Notes

- For grilling, place the whole fish, e.g. trout, onto the middle of the wire rack.
- For braised fish, cook the whole fish in its swimming position.

-  Centre-area grill
-  Full-surface grill

Fish	Accessories	Level	Type of heating	Grill setting	Microwave power in watts	Cooking time in minutes
Whole fish, e.g. trout approx. 300 g, grilled	Universal pan + Wire rack*	1 3		2	-	1st side: approx. 10-15 2nd side: approx. 8-12
Fish steak, e.g. salmon 3 cm thick, grilled	Universal pan + Wire rack*	1 3		3	-	1st side: approx. 10-12 2nd side: approx. 8-12
2 or 3 whole fish, 300 g each, grilled	Universal pan + Wire rack*	1 3		2	-	1st side: approx. 10-15 2nd side: approx. 10-15
Whole fish, approx. 1 kg, braised	Ovenware with lid, wire rack	1	-	-	600 W	10-15
Whole fish, approx. 1.5 kg, braised	Ovenware with lid, wire rack	1	-	-	600 W 360 W	10-15 5-10
Whole fish, approx. 2 kg, braised	Ovenware with lid, wire rack	1	-	-	600 W 360 W	15-20 10-15
Fish fillet, e.g. pollock, approx. 800 g, braised	Ovenware with lid, wire rack	1	-	-	600 W	9-14

* Grease the wire rack first with oil.





Tips for roasting and grilling









The table does not contain information for the weight of the joint. For small roasts, select a higher temperature and a shorter cooking time. For larger roasts, select a lower temperature and a longer cooking time.

How to tell when the roast is ready.	Use a meat thermometer (available from specialist shops) or carry out a "spoon test". Press down on the roast with a spoon. If it feels firm, it is ready. If the spoon can be pressed in, it needs to be cooked for a little longer.
The roast looks good but the juices are burnt.	Next time, use a smaller roasting dish or add more liquid.
The roast looks good but the juices are too clear and watery.	Next time, use a larger roasting dish and add less liquid.
The roast is not well-done enough.	Carve the roast. Prepare the gravy in the roasting dish and place the slices of roast meat in the gravy. Finish cooking the meat using the microwave only.

Bakes, gratins, toast with toppings



Notes









- The values in the table apply to food placed in a cold oven.
- Use large flat ovenware for bakes and gratins. Food takes longer to cook in narrow, deep containers and browns more on top.
- Place the bake in microwaveable ovenware on the wire rack.
- Leave bakes and gratins to cook in the oven for a further 5 minutes after switching off.
- Use a 4 to 5 cm deep ovenproof dish for bakes, potato gratins and lasagne.
- Place soufflés in individual moulds or in a deep ovenproof dish. Preheat the cooking compartment.
- Toast with topping: lay 4 slices next to each other in the centre of the universal pan. Distribute 12 slices evenly over the universal pan.
-  Circo-roasting
-  Hot air
-  Top/bottom heating
-  Centre-area grill
-  Full-surface grill

Bakes, gratins, toast with toppings	Accessories	Level	Type of heating	Temperature in °C, grill setting	Microwave power in watts	Cooking time in minutes
Bake, sweet, approx. 1.5 kg	Ovenware with lid, Wire rack	1		140-160	360 W	25-35
Soufflé	Ovenware without lid, Wire rack	1		160-180	-	40-45
Soufflé in individual moulds	Wire rack	1		200-210	-	12-17
Pasta bake, approx. 1 kg	Ovenware without lid, Wire rack	1		140-160	600 W	20-30
Lasagne, approx. 2 kg	Ovenware without lid, Wire rack	2		180-200	600 W	20-30
Potato gratin made from raw ingredients, approx. 1.1 kg	Ovenware without lid, Wire rack	1		170-190	600 W	20-25
Toast with topping, 4 slices	Universal pan	2		3	-	8-13
Toast with topping, 12 slices	Universal pan	2		3	-	9-14

Convenience products

Notes

- Please observe the instructions on the packaging.
- The values in the table apply to food placed in a cold oven.
- Do not lay chips, croquettes or potato röstis on top of each other.
- Turn fish fingers, chicken goujons, nuggets and veggie burgers halfway through the cooking time.
- Place cream gâteau on the oven floor without accessories, level 0.
-  Top/bottom heating
-  Hot air
-  Circo-roasting

Convenience products	Accessories	Level	Type of heating	Temperature °C	Microwave power in watts	Cooking time in minutes
Pizza with thin base	Universal pan	1		210-230	-	20-25
Pizza with deep-pan base	Universal pan	2		200-220	90 W	15-25
Mini pizza	Universal pan	2		210-230	-	15-20
Pizza baguette	Universal pan	2		180-190	-	15-20
Chips	Universal pan	2		220-230	-	20-25
Croquettes	Universal pan	2		200-220	-	25-35
Rösti, stuffed potato pockets	Universal pan	2		200-220	-	25-35
Bread rolls, baguette	Wire rack	2		200-220	-	15-20

* Line the universal pan with greaseproof paper.

The greaseproof paper must be suitable for these temperatures.

Convenience products	Accessories	Level	Type of heating	Temperature °C	Microwave power in watts	Cooking time in minutes
Pretzels, dough	Universal pan*	2		190-210	-	20-25
Part-cooked rolls or baguette	Wire rack	2		140-150	-	12-15
Fish fingers	Universal pan	2		190-210	180 W	10-15
Chicken goujons, nuggets	Universal pan	2		190-210	360 W	15-20
Veggie burgers	Universal pan	2		200-220	180 W	15-25
Strudel	Universal pan	2		200-220	90 W	20-25
Lasagne	Wire rack	2		200-210	180 W	18-23
Cream gateau	-	0		30	-	120-150

* Line the universal pan with greaseproof paper.

The greaseproof paper must be suitable for these temperatures.

Slow cooking

In this section, you will find information on

- Low-temperature cooking
- Tips and tricks

Low-temperature cooking is a method of cooking slowly at low temperatures, and is also known as low-temperature cooking.

Low-temperature cooking is ideal for all prime cuts of meat (e.g. tender portions of beef, veal, pork, lamb and poultry) that are to be cooked medium/medium rare or "à point". The meat will remain succulent and tender.

Using low-temperature cooking

Only switch on low-temperature cooking when the cooking compartment has completely cooled down (to room temperature).

If "Not possible" appears in the text display when the Low-temperature cooking mode is switched on and **H** or **h** and **III** appear alternately in the temperature display, the cooking compartment has not cooled down completely.

Wait until the cooking compartment has cooled down and switch on low-temperature cooking again.

1. Use ovenware with a properly fitting, matching lid, e.g. a glass roasting dish. Place the roasting dish on the wire rack.
2. Select low-temperature cooking and a temperature between 70 and 100 °C. Preheat the cooking compartment, thus warming the ovenware at the same time.
During the heating phase (15 minutes), "Please wait" appears on the text display.
3. Remove fat and sinews from the meat.
4. Sear the meat on all sides to seal it and to create a roasted flavour.
5. When a signal sounds and "In operation" appears in the text display, place the meat on the glass or porcelain plate in the cooking compartment.
6. Take out the meat at the end of the cooking time and switch off the appliance.

Note: Meat cooked at a low temperature does not need to be rested and can be kept warm at a low temperature without any problems.

Note the following points:

Notes

- Only use fresh, clean meat
- Only use boned meat.
- Do not use defrosted meat.

- You can also use seasoned or marinated meat.
- The properties of the pan and the heat output of the hotplate can influence the searing time.
- Always use shelf height 1 for low-temperature cooking.
- You can also slow cook your meat in ovenware without a lid. The cooking times will be increased.
- Do not turn pieces of meat during low-temperature cooking.
- In order to check whether the meat is cooked, use a meat thermometer. A core temperature of 60 °C should be maintained for at least 30 minutes.
- The meat will always look pink on the inside after low-temperature cooking. This does not mean that the cooking time was too short.
- The size, thickness and type of meat will have a significant influence on the searing and low-temperature cooking times.
- Do not use low-temperature cooking together with the preselection mode timer function

Slow cooking

Notes

- The information in the table is only a guideline. The searing time refers to in a hot pan with fat.
- Use ovenware with a properly fitting, matching lid, e.g. a glass roasting dish. Place the roasting dish on the wire rack.

Low-temperature cooking

Slow cooking	Level	Type of heating	Temperature °C	Cooking time in minutes
Poultry				
Turkey breast	1		80	240-270
Skinless duck breast	1		80	110-140
Beef				
Beef joint (e.g. rump)	1		80	270-300
Fillet of beef	1		80	150-180
Sirloin	1		80	180-220
Beef steaks, 3 cm thick	1		80	70-100
Veal				
Joint of veal (e.g. veal olive)	1		80	180-220

Slow cooking	Level	Type of heating	Temperature °C	Cooking time in minutes
Fillet of veal	1		80	80-100
Pork				
Joint of pork (e.g. loin)	1		80	180-210
Pork fillet	1		80	140-170
Lamb				
Lamb fillet	1		80	40-70

Tips for slow cooking

Slow-cooked meat is not as hot as conventionally roasted meat. So that the roasted meat does not cool too fast, warm the plates and serve the gravy very hot.

If you wish to keep slow-cooked meat warm. After slow cooking, turn the temperature down to 70 °C. Small pieces of meat can be kept warm for up to 45 minutes, larger pieces for up to 2 hours.

Test dishes

The quality and function of microwave combination appliances are tested by testing institutes using the following dishes.

According to the standards EN 60705, IEC 60705/DIN 44547 and EN 60350 (2009)

Defrosting with the microwave

Dish	Microwave power setting in watts, cooking time in minutes	Note
Meat	180 W, 5 mins + 90 W, 10-15 mins	Place 22 cm Pyrex dish on the wire rack at level 1. After approx. 10 minutes, remove the defrosted meat.

Microwave cooking

Dish	Microwave power setting in watts, cooking time in minutes	Note
Custard	360 W, 10 mins + 180 W, 20-25 mins	Place Pyrex dish on the wire rack at level 1.
Sponge	600 W, 8-10 mins	Place 22 cm Pyrex dish on the wire rack at level 1.
Meat loaf	600 W, 20-25 mins	Place Pyrex dish on the wire rack at level 1.

■ Circu-roasting

■ Top/bottom heating

Combined microwave cooking

Dish	Microwave power setting in watts, cooking time in minutes	Type of heating	Temperature °C	Note
Potato gratin	600 W, 20-25 mins		170-190	Place 22 cm Pyrex dish on the wire rack at level 1.
Cake	180 W, 15-20 mins		180-200	Place 22 cm pyrex dish on the wire rack at level 1.
Chicken*	360 W, 30-35 mins		200-220	Turn after 15 minutes.

* Slide the wire rack in at level 2 and the universal pan in at level 1.

Baking

Notes

- The values in the table apply to food placed in a cold oven.
- Apple pie: place the dark springform cake tins diagonally alongside one another.

■ Top/bottom heating



■ Hot air

■ Hot air plus

	Ovenware	Level	Type of heating	Temperature °C	Baking time in minutes
Viennese whirls	Universal pan	2		160-180	20-30
	Universal pan	2		150-170	20-30
	Universal pan* + Enamel baking tray**	1 3		140-150	30-40
Small cakes	Universal pan	2		160-180	25-35
	Universal pan	2		140-160	25-35
Small cakes	Universal pan* + Enamel baking tray**	1 3		150-170	35-45
Hot water sponge cake	Springform cake tin on the wire rack	1		160-170	30-40

* When baking on two levels, always slide in the enamel baking tray above the universal pan.

** Enamel baking trays can be obtained as an optional accessory from specialist retailers.



	Ovenware	Level	Type of heating	Temperature °C	Baking time in minutes
Yeast cakes on a baking tray	Universal pan	2		170-190	45-55
	Universal pan* + Enamel baking tray**	1 3		160-180	50-60
Apple pie	2 x 20 cm springform cake tins on the wire rack	2		170-190	70-90

* When baking on two levels, always slide in the enamel baking tray above the universal pan.

** Enamel baking trays can be obtained as an optional accessory from specialist retailers.

Grilling

 Full-surface grill

Dish	Accessories	Level	Type of heating	Grill setting	Cooking time in minutes
Toasting bread*	Wire rack	3		3	1-2
12 beefburgers**	Wire rack and Universal pan	3 1		3	30

* Preheat for 5 minutes.

** Turn halfway through the cooking time.

Acrylamide in foodstuffs

Which foods are affected?

Acrylamide is mainly produced in grain and potato products that are heated to high temperatures, such as potato crisps,

chips, toast, bread rolls, bread, fine baked goods (biscuits, gingerbread, cookies).

Tips for keeping acrylamide to a minimum when preparing food

General	Keep cooking times to a minimum. Cook meals until they are golden brown, but not too dark. Large, thick pieces of food contain less acrylamide.
Baking biscuits	Max. 200 °C with Top/bottom heat or max. 180 °C with Hot air plus or Hot air. Max. 190 °C with Top/bottom heat or max. 170 °C with Hot air plus or Hot air mode. Egg white and egg yolk reduce the formation of acrylamide.
Oven chips	Distribute thinly and evenly over the baking tray. Cook at least 400 g at once on a baking tray so that the chips do not dry out.



Constructa Neff
Vertriebs-GmbH
Carl-Wery-Straße 34
D-81739 München

Register your product online

www.neff-international.com



9000731955

45

(03) 940328