



Combination steam oven  
C47C22.3.



# en Table of contents

<b>Important safety information</b> .....	<b>4</b>
Causes of damage .....	5
<b>Your new appliance</b> .....	<b>6</b>
Control panel .....	6
Operating modes .....	7
Automatic calibration .....	7
<b>Your accessories</b> .....	<b>7</b>
Accessories .....	7
Inserting accessories .....	8
Cooking compartment .....	8
Optional accessories .....	8
<b>Before using for the first time</b> .....	<b>9</b>
Setting the clock .....	9
Setting the water hardness range .....	9
First use .....	9
Cleaning the accessories before use .....	9
<b>Operating the appliance</b> .....	<b>10</b>
Filling the water tank .....	10
Switching on the appliance.....	10
Switching off the appliance.....	11
After each use .....	11
<b>Electronic clock</b> .....	<b>11</b>
Clock display .....	11
Timer .....	12
Cooking time .....	12
End of operation .....	12
Preset operation.....	13
Setting the clock.....	13
Checking, correcting or deleting settings .....	13
<b>Automatic programmes</b> .....	<b>13</b>
Setting a programme .....	13
Notes about the programmes .....	14
Programme table .....	15
<b>Childproof lock</b> .....	<b>16</b>
Lock.....	16
Permanent lock .....	16
<b>Basic settings</b> .....	<b>17</b>
<b>Automatic safety cut-out</b> .....	<b>17</b>
<b>Care and cleaning</b> .....	<b>17</b>
Cleaning agents .....	18
Oven cleaning aid.....	18
Descaling.....	19
Removing and fitting the appliance door.....	20
Cleaning the door panels.....	20
Cleaning the rails.....	21
<b>Troubleshooting</b> .....	<b>22</b>
Replacing the cooking compartment bulb .....	23
Changing the door seal.....	23
<b>After-sales service</b> .....	<b>24</b>
E number and FD number .....	24
<b>Environmental protection</b> .....	<b>24</b>
Environmentally-friendly disposal.....	24
Tips for saving energy .....	24

<b>Tables and tips</b> .....	<b>25</b>
Steam cooking .....	25
Hot air .....	25
CircoSteam® .....	25
Vegetables .....	25
Side dishes and pulses .....	26
Poultry and meat.....	27
Fish.....	28
Bakes, soup ingredients, etc.....	29
Dessert, compote .....	29
Cakes and pastries .....	29
Reheating food.....	31
Defrosting.....	31
Proving dough.....	32
Juicing.....	32
Preserve.....	32
Frozen products.....	32
<b>Test dishes</b> .....	<b>34</b>
Baking.....	34
Steaming .....	34

---

Additional information on products, accessories, replacement parts and services can be found at [www.neff-international.com](http://www.neff-international.com) and in the online shop [www.neff-eshop.com](http://www.neff-eshop.com)

## Important safety information

Read these instructions carefully. Only then will you be able to operate your appliance safely and correctly. Retain the instruction manual and installation instructions for future use or for subsequent owners.

This appliance is only intended to be fully fitted in a kitchen. Observe the special installation instructions.

Check the appliance for damage after unpacking it. Do not connect the appliance if it has been damaged in transport.

Only a licensed professional may connect appliances without plugs. Damage caused by incorrect connection is not covered under warranty.

This appliance is intended for domestic use only. The appliance must only be used for the preparation of food and drink. The appliance must be supervised during operation. Only use this appliance indoors.

This appliance may be used by children over the age of 8 years old and by persons with reduced physical, sensory or mental capabilities or by persons with a lack of experience or knowledge if they are supervised or are instructed by a person responsible for their safety how to use the appliance safely and have understood the associated hazards.

Children must not play with the appliance. Children must not clean the appliance or carry out general maintenance unless they are at least 8 years old and are being supervised.

Keep children below the age of 8 years old at a safe distance from the appliance and power cable.

Always slide accessories into the cooking compartment correctly. See "*Description of accessories*" in the instruction manual.

### **Risk of fire!**

- Combustible items stored in the cooking compartment may catch fire. Never store combustible items in the cooking compartment. Never open the appliance door if there is smoke inside. Switch off the appliance and unplug it from the mains or switch off the circuit breaker in the fuse box.
- A draught is created when the appliance door is opened. Greaseproof paper may come into contact with the heating element and catch fire. Do not place greaseproof paper loosely over accessories during preheating. Always weight down the greaseproof paper with a dish or a baking tin. Only cover the surface required with greaseproof paper. Greaseproof paper must not protrude over the accessories.

### **Risk of burns!**

- The appliance becomes very hot. Never touch the interior surfaces of the cooking compartment or the heating elements. Always allow the appliance to cool down. Keep children at a safe distance.
- Accessories and ovenware become very hot. Always use oven gloves to remove accessories or ovenware from the cooking compartment.
- Alcoholic vapours may catch fire in the hot cooking compartment. Never prepare food containing large quantities of drinks with a high alcohol content. Only use small quantities of drinks with a high alcohol content. Open the appliance door with care.
- Hot steam may escape during operation. Do not touch the ventilation openings. Keep children away.

## **Risk of scalding!**

- The accessible parts become hot during operation. Never touch the hot parts. Keep children at a safe distance.
- Water in a hot cooking compartment may create hot steam. Never pour water into the hot cooking compartment.
- When you open the appliance door, hot steam can escape. Steam may not be visible, depending on its temperature. When opening, do not stand too close to the appliance. Open the appliance door carefully. Keep children away.
- The water in the evaporator dish is still hot even after the appliance has been switched off. Do not empty the evaporator dish immediately after switching off the appliance. Allow the appliance to cool down before cleaning it.
- Hot liquid may spill over the sides of cooking containers when they are removed from the cooking compartment. Remove hot cooking containers with care and always wear oven gloves.

## **Risk of injury!**

- Scratched glass in the appliance door may develop into a crack. Do not use a glass scraper, sharp or abrasive cleaning aids or detergents.
- Flammable liquids can catch fire in the cooking compartment when it is hot (explosion). Do not fill the water tank with any flammable fluids (e.g. alcoholic drinks). Only fill the water tank with water or with the descaling solution that is recommended by us.

## **Risk of electric shock!**

- Incorrect repairs are dangerous. Repairs may only be carried out by one of our trained after-sales engineers. If the appliance is faulty, unplug the mains plug or switch off the fuse in the fuse box. Contact the after-sales service.
- The cable insulation on electrical appliances may melt when touching hot parts of the appliance. Never bring electrical appliance cables into contact with hot parts of the appliance.
- Penetrating moisture may cause an electric shock. Do not use any high-pressure cleaners or steam cleaners.

- When replacing the cooking compartment bulb, the bulb socket contacts are live. Before replacing the bulb, unplug the appliance from the mains or switch off the circuit breaker in the fuse box.
- A defective appliance may cause electric shock. Never switch on a defective appliance. Unplug the appliance from the mains or switch off the circuit breaker in the fuse box. Contact the after-sales service.

## **Causes of damage**

### **Caution!**

- Do not place anything on the cooking compartment floor. Do not cover it with aluminium foil. A build-up of heat could damage the appliance.  
The cooking compartment floor and the evaporator dish must always be kept clear. Always place ovenware in a perforated cooking container or on a wire rack.
- Aluminium foil in the cooking compartment must not come into contact with the door panel. This could cause permanent discolouration of the door panel.
- Ovenware must be heat and steam resistant. Silicone baking tins are not suitable for combined operation with steam.
- Do not use ovenware that shows signs of rust. Even the smallest spots of rust can lead to corrosion in the cooking compartment.
- When steaming with a perforated cooking container, always insert the baking tray or the solid cooking container underneath. Dripping liquid is caught.
- Do not store moist food in the closed cooking compartment for long periods. It can lead to corrosion in the cooking compartment.
- Fruit juice may leave stains in the cooking compartment. Always remove fruit juice immediately and wipe the cooking compartment with a moist and dry cloth.
- If the door seal is very dirty, the appliance door will no longer close properly during operation. The fronts of adjacent units could be damaged. Always keep the door seal clean and replace when necessary.
- Do not place anything on the open appliance door. The appliance could be damaged.
- Do not carry or hold the appliance by the door handle. The door handle cannot support the weight of the appliance, and could break.
- The cooking compartment in your appliance is made of high grade stainless steel. Improper care can lead to corrosion in the cooking compartment. Refer to the care and cleaning instructions in the instruction manual. Remove food residues from the cooking compartment as soon as the appliance has cooled.

# Your new appliance

In this section, you will find information on

- the control panel
- the operating modes
- automatic calibration

## Control panel

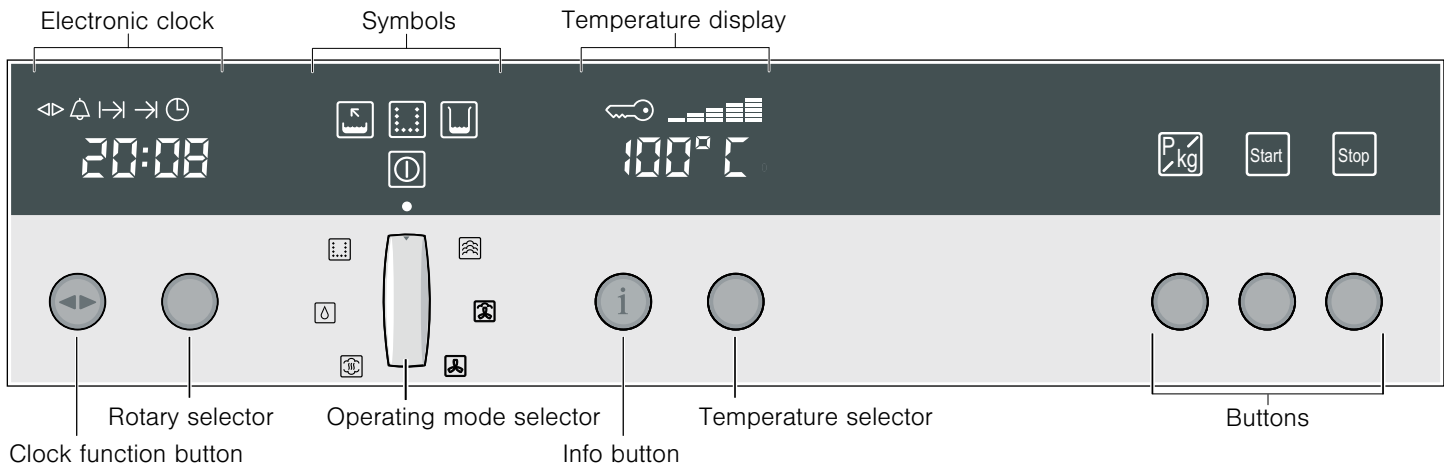







Control element	Use/meaning	
Operating mode selector	Switching the appliance on and off Selects the desired operating mode	
<b>Electronic clock</b>		
◀▶	Clock function button	Selects the clock function (see section: Electronic clock)
	Rotary selector	Makes settings within a clock function (see section: Electronic clock)
<b>Symbols</b>		
	Emptying the evaporator dish	If the symbol  lights up: Remove the remaining water from the evaporator dish.
	Descaling	When the  symbol flashes, the appliance needs descaling (see section: Descaling)
	Fill the water tank	When the symbol  lights up, fill the water tank or change the water in the water tank (e.g. during descaling)
<b>Temperature display (Basic settings)</b>		
	Info button	Press briefly: calls up additional information, for example the current temperature during the heating up phase Press and hold: calls up the Basic settings menu (see section: Changing the Basic settings)
	Temperature selector	Sets the temperature Changes the settings in the Basic settings menu (see section: Changing the Basic settings)
<b>Buttons</b>		
	Programme button	Set the programme or enter the weight (see section: Automatic programmes)
	Start button	Starts operation
	Stop button	Short press: stops the operation (pause) Press and hold: ends the operation

## Pop-out operating knob

The rotary, temperature and operating mode selectors can all be popped out. Push the required operating knob to pop it in or out.

## Operating modes

You can use the operating mode selector to set your appliance for various different applications.

Operating mode	Application
 Steam cooking 35 - 100 °C	For vegetables, fish, side dishes, for juicing fruit and for blanching. For proving dough (at 35 °C).
 CircoSteam® 120 - 230 °C	For meat, bakes, and pastries. Hot air and steam are combined.
 Hot air 30 - 230 °C	For moist cakes, sponges and pot roasts. A fan in the back wall of the oven distributes the heat evenly inside the cooking compartment.
 Reheat 100 - 180 °C	For plated meals and baked items. Cooked food is gently reheated. The steam ensures that the food does not dry out.
 EasyClean®	Makes cleaning the cooking compartment easier (See the section: Cleaning aid EasyClean®)
 Descaling	For descaling the water system and the evaporator dish (see section: Descaling)

## Automatic calibration

The boiling temperature of water depends on the air pressure. During calibration, the appliance is adapted to the pressure conditions in the location where it is installed. This happens automatically when you first use the appliance (see section: First use). More steam develops than usual.

It is important that the appliance steams without interruption for 20 minutes at 100 °C. Do not open the appliance door during this time.

If the appliance was not able to calibrate itself automatically (for example, because the appliance door was opened), the calibration process is carried out again during the next cooking operation.

### After moving house

So that the appliance automatically adjusts itself to its new location, you must reset the appliance to the factory settings (see section: Basic settings) and repeat the initial start-up process (see section: First use).

### After a power cut

The appliance saves the calibration settings even in the event of a power cut or disconnection from the mains. Recalibration is not necessary.

## Your accessories

The accessories supplied with your appliance are suitable for making many dishes. Ensure that you always insert the accessories into the cooking compartment the right way round.

### Accessories

The following accessories are supplied with your appliance:

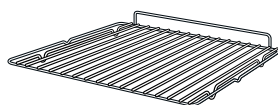

#### Wire rack

For ovenware, cakes and ovenproof dishes, and for roasting

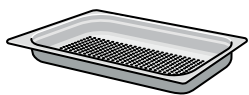

#### Cooking container, perforated, GN 1/3, 40 mm deep

For steaming vegetables, juicing berries and defrosting



#### Cooking container, solid, GN 1/3, 40 mm deep

For cooking rice, pulses and cereals

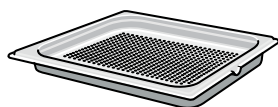

#### Cooking container, perforated, GN 2/3, 40 mm deep

for the steaming of whole fish or large quantities of vegetables, for juicing berries, etc.



#### Cooking container, solid, GN 2/3, 28 mm deep (baking tray)

For baking tray bakes and for catching dripping liquid during steaming

You can buy accessories from the after-sales service, from specialist retailers or online.

**Note:** The cooking containers may warp during and after cooking. This is caused by the considerable temperature differences acting on the accessories. It may occur if only a part of the accessory is occupied with food or if you place frozen items, such as pizza, on the accessory. Once accessories cool down again, they regain their original shape. This does not affect their function.

## Inserting accessories

The accessories are equipped with a locking function. The locking function prevents the accessories from tilting when they are pulled out. The accessories must be inserted into the cooking compartment correctly for the tilt protection to work properly.

When inserting the wire rack, check

- that the lug (a) is pointing downwards
- that the safety lug on the wire rack is at the back and facing upwards.

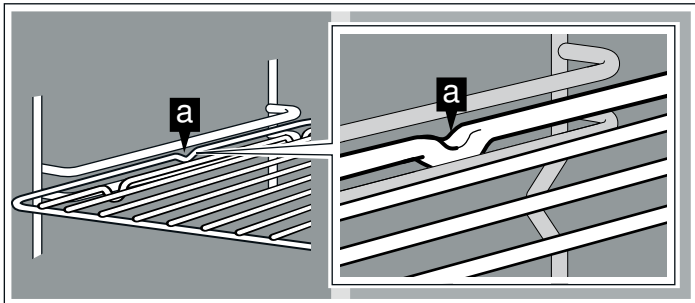

When inserting the cooking container, ensure that the lug (a) is facing downwards.

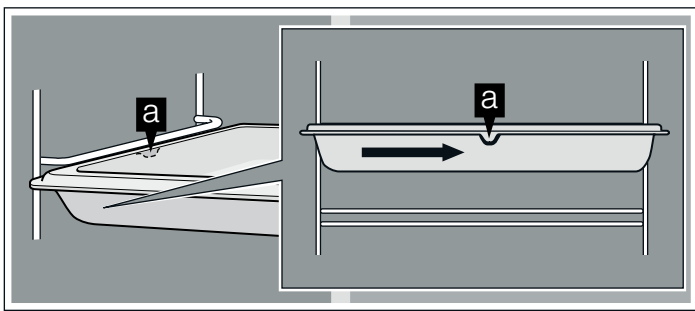

## Cooking compartment

The cooking compartment has four shelf positions. The shelf positions are counted from the bottom up.

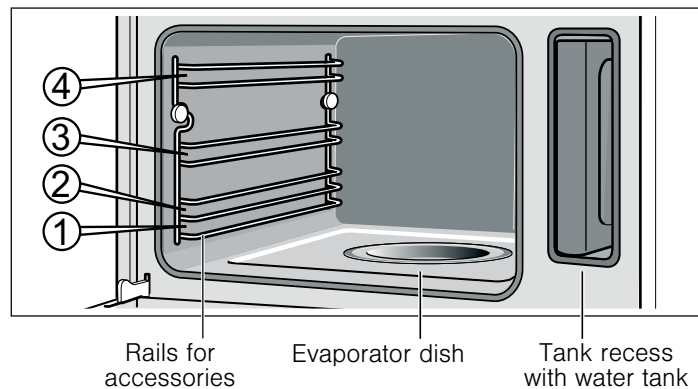

### Caution!

- Do not place anything on the cooking compartment floor. Do not cover it with aluminium foil. A build-up of heat could damage the appliance.

The cooking compartment floor and the evaporator dish must always be kept clear. Always place ovenware in a perforated cooking container or on a wire rack.

- Do not slide any accessories between the shelf positions, or they may tip.

## Optional accessories

You can obtain further accessories from specialist retailers:

Accessories	Order no.
Cooking container, solid, GN $\frac{2}{3}$ , 40 mm deep	Z1683X3
Cooking container, perforated, GN $\frac{2}{3}$ , 40 mm deep	Z1682X3
Cooking container, solid, GN $\frac{2}{3}$ , 28 mm deep (baking tray)	Z1673X3
Cooking container, solid, GN $\frac{1}{3}$ , 40 mm deep	Z1663X0
Cooking container, perforated, GN $\frac{1}{3}$ , 40 mm deep	Z1662X0
Porcelain cooking container, solid, GN $\frac{2}{3}$	Z1685X0
Porcelain cooking container, solid, GN $\frac{1}{3}$	Z1665X0
Wire rack	Z1664X3
Roasting set	Z1684X3
Grease filter	Z1610X0
Cleaning sponge	643 254
Descaler	311 138
Honeycomb microfibre cloth	460 770



# Before using for the first time

In this section you will find out which steps are required before using the appliance for the first time:

- Setting the clock
- Setting the water hardness range
- Starting the appliance for the first time
- Cleaning the accessories before use

## Setting the clock

**Note:** When you press the ◀▶ clock function button, you have 3 seconds to set the clock using the rotary selector. Should this have been insufficient for you, you can amend the clock time later.

0:00 flashes in the clock display.

1. Briefly press the ◀▶ clock function button to go to the setting mode.  
The ◀▶ and ⌚ symbols light up. 12:00 appears in the clock display.
2. Set the current time using the rotary selector.  
Your setting is accepted after 3 seconds.

## Changing the clock

To subsequently change the time, press the ◀▶ clock function button repeatedly until the ◀▶ and ⌚ symbols light up again. Change the time with the rotary selector.



## Setting the water hardness range

### Caution!

The appliance may become damaged due to the use of unsuitable liquids.

Do not use distilled water, highly chlorinated tap water (> 40 mg/l) or other liquids.

Only use cold, fresh tap water, softened water or uncarbonated mineral water.

The water hardness "medium" (c 52) is the default setting. Change the value if your water is softer or harder.

You can check the water hardness with the test strips supplied or ask your water supplier.

## Notes

- If your water is very hard, we recommend that you use softened water.
- If you use only softened water, you can set your appliance to the "softened" water hardness range.
- If you use mineral water, set the water hardness to hard.
- If you use mineral water, you must only use non-carbonated mineral water (see section "Filling and emptying the water tank").

You can change the water hardness range in the basic settings when the appliance is switched on.

1. If required, turn the operating mode selector to the O position.
2. Press and hold the i information button until c 10 appears in the temperature display.
3. Briefly press the i information button repeatedly until c 52 appears in the temperature display (water hardness "medium").
4. Use the temperature selector to set the water hardness.

Water hardness	Setting symbol (temperature display)
softened	c 50
soft	c 51
medium	c 52
hard	c 53
very hard	c 54

5. Press and hold the i info button for 3 seconds.  
Your setting is saved.

## First use

Before first use, heat the empty appliance with Steam cooking for 20 minutes at 100 °C. Do not open the appliance door during this time. The appliance is automatically calibrated (see section: Automatic calibration).

1. Press the operating mode selector so that it pops out.  
The appliance switches on.
2. Fill and insert the water tank (see section: Filling the water tank).  
Before using for the first time, moisten the seal in the tank cover with a little water.
3. Turn the operating mode selector round to Steam cooking.
4. Press the Start button.  
The appliance heats up to 100 °C. The cooking time (20 minutes) does not start to count down until the set temperature has been reached. Do not open the appliance door during this time.  
The cooking operation ends automatically and an audible signal sounds.
5. Press the ◀▶ clock function button to exit the clock function.
6. Turn the operating mode selector back to the O position and click in place to turn off the appliance.  
Leave the appliance door ajar until the appliance has cooled down.

## Cleaning the accessories before use

Using soapy water and a soft cloth, clean the accessories thoroughly before first use.

# Operating the appliance

In this section, you can read about

- how to fill the water tank
- how to switch the appliance on and off
- what to note after each cooking operation

## Filling the water tank

When you open the appliance door, you will see the water tank on the right-hand side.

### Caution!

Use of unsuitable liquids may damage the appliance

- Only use fresh tap water, softened water or uncarbonated mineral water.
- If your tap water is very hard, we recommend that you use softened water.
- Do not use distilled water, highly chlorinated tap water (> 40 mg/l) or other liquids.

You can obtain information about your tap water from your water supplier. The water hardness can be checked with the test strips enclosed.

Fill the water tank before each use:

1. Open the appliance door and take out the water tank (fig. A).
2. Fill the water tank with cold water up to the "max" mark (fig. B).

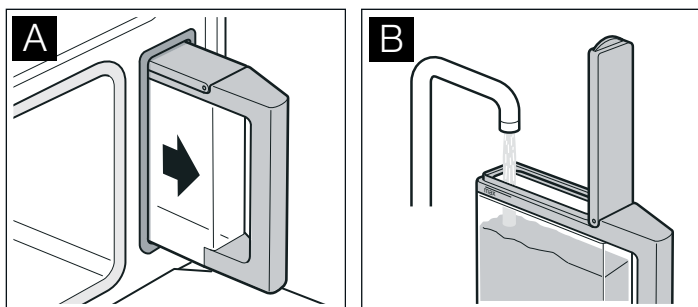

3. Close the tank cover until you feel it engage.
4. Slide in the water tank all the way (fig. C).

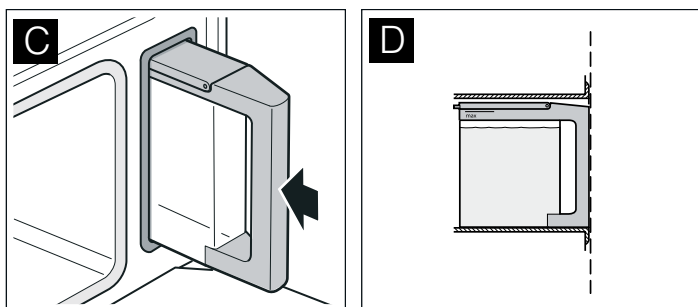

The tank must be flush with the water tank recess (fig. D).

## Switching on the appliance

### ⚠ Risk of scalding!

When you open the appliance door and remove the cooking containers, hot liquids may squirt out because the cooking containers may have warped. When opening, do not stand too close to the appliance. Open the appliance door carefully. Remove the cooking container carefully. Keep children at a safe distance.

**Note:** Always use the cooking container and wire rack in their standard position (not the other way up).



1. Press the operating mode selector so that it pops out. The appliance switches on.
2. Turn the operating mode selector until the required operating mode lights up. A default temperature appears on the temperature display.

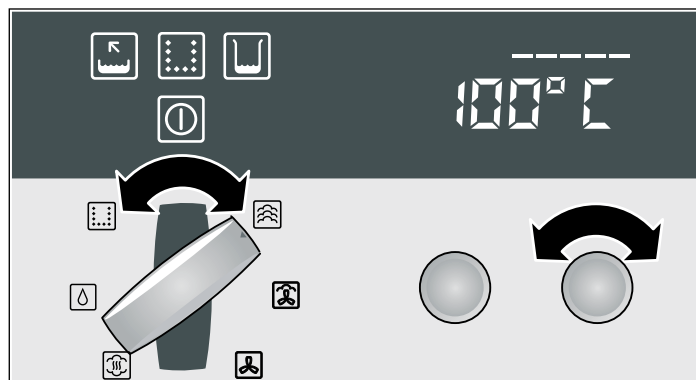

3. Turn the temperature selector to change the default temperature.

Operating mode	Temperature range	Default cooking time
Steam cooking	35 - 100 °C	20 minutes
CircoSteam®	120 - 230 °C	30 minutes
Hot air	30 - 230 °C	-
Reheat	80 - 100 °C	10 minutes

For operating modes that use steam, a default cooking time appears in the clock display. The ◀▶ and |→| (cooking time) symbols light up.

4. Turn the rotary selector to change the default cooking time. The new cooking time is saved automatically after 3 seconds. You can also set the cooking time for operating modes that do not use steam (see section: Electronic clock).
5. Press the Start button. If you do not press the Start button, an audible signal sounds.

When Steam cooking, the cooking time does not start until the heating time has elapsed.

### Heating indicator

The heating indicator displays the rising temperature in the cooking compartment.

- Temperature reached (fig. A)
- Appliance reheating (fig. B)



### Current temperature

Press the info button. The current temperature is displayed for 3 seconds.

### Displaying and changing the cooking time.

Press the <|> clock function button repeatedly until the <|> and |> symbols light up. The current cooking time is displayed. Turn the rotary selector to change the cooking time. The change is saved automatically.

### Changing the temperature

You can change the temperature at any time. To change the temperature, turn the temperature selector until the required temperature is displayed.

### Pause

Briefly press the Stop button to interrupt cooking (pause). The cooling fan may continue running. Press the Start button to restart.

If you open the appliance door during cooking, operation is interrupted. Close the appliance door and press the Start button to restart.

If you have switched on the Auto start, there is no need to restart the appliance (see section: Basic settings).

### Display

When the water tank is empty, an audible signal sounds and the  indicator appears. Cooking is interrupted.

1. Open the appliance door carefully.  
N.B.: Hot steam will escape.
2. Remove the water tank, fill up to the "max" mark and slide the tank back in.
3. Press the Start button.

### Switching off the appliance

#### Risk of scalding!

Hot steam may escape when the appliance door is opened. Open the appliance door carefully during or after cooking. When opening the door, do not lean over it. Ensure that, depending on the temperature, steam is not visible.

Press and hold the Stop button to stop the cooking.

If you have set a cooking time, cooking is ended automatically. A signal sounds. Press the <|> clock function button to stop the signal.

The cooling fan may continue to run when you open the appliance door.

Turn the operating mode selector back to the 0 position and push it in to turn off the appliance.

You can see in the temperature display whether there is high or low residual heat in the cooking compartment.

Temperature display	Meaning
H	Residual heat high
h	Residual heat low

### After each use

#### Emptying the water tank.

1. Open the appliance door carefully.  
Hot steam will escape.
2. Remove and clean the water tank.
3. Thoroughly dry the seal in the tank cover and the tank recess in the appliance.

#### Caution!

Do not dry the water tank in the hot cooking compartment. This will damage the water tank.

#### Drying the cooking compartment

##### Risk of scalding!

The water in the evaporator dish may still be hot. Allow it to cool before wiping.

1. Leave the appliance door ajar until the appliance has cooled down.
2. Once it has cooled down, wipe out the cooking compartment and the evaporator dish with the enclosed cleaning sponge and dry well with a soft cloth.
3. Remove food residues from the cooking compartment as soon as the appliance has cooled. Burnt-on remains will be much harder to remove later.
4. Wipe kitchen units or handles if condensation has formed on them.

## Electronic clock

In this section, you can read about

- how to set the timer
- how to switch your appliance off automatically (cooking time and end of operation)
- how to switch your appliance on and off automatically (preset operation)
- how to set the time

### Clock display

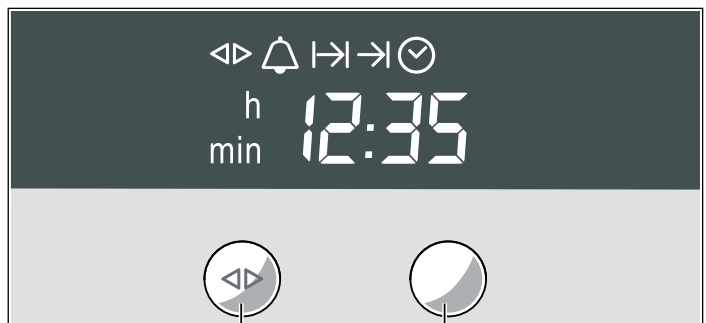

Clock function button

Rotary selector

Clock function	Use
Minute minder	You can use the minute minder as an egg timer or a kitchen timer. The appliance does not switch on or off automatically
Cooking time	The appliances switches off automatically after a cooking time setting has elapsed (e.g. <b>1:30</b> hours)
End of operation	The appliance switches off automatically at a set time (e.g. <b>12:30</b> o'clock)
Preset operation	The appliance switches on and off automatically. Cooking time and end of operation have been combined.
Clock	Setting the clock

### Notes

- Between the times **22:00** and **5:59** the clock display is dimmed if you do not make any settings in that period or no clock function is activated.
- When you set a clock function, the time interval increases when you set higher values (e.g. cooking time up to **1:00h** to the minute, using **1:00h** to the nearest 5 minutes).
- For the minute minder, cooking time, end of operation and preselection mode clock functions, a signal sounds when the settings have elapsed and the or symbol flashes. To cancel the audible signal before it ends, press the clock function button.
- Briefly press the clock function button to select a clock function. You then have 3 seconds to set the selected clock function. After this time, the setting mode is exited automatically.

### Switching the clock display on and off

1. Press and hold the clock function button for 6 seconds. The clock display switches off. If a clock function is active, the associated symbol remains lit.
2. Press the clock function button briefly. The clock display switches on.

### Timer

1. Press the clock function button repeatedly until the and symbols light up.
2. Set the duration using the rotary selector (e.g. **5:00** minutes). The setting is applied automatically. Then the clock is displayed again and the minute minder starts counting down.



### Cooking time

Automatic switch-off after a cooking time setting has elapsed.

1. Set the operating mode and temperature.
2. Press the clock function button repeatedly until the and symbols light up.
3. Set the cooking time with the rotary selector (e.g. **1:30** hours).
4. Press the Start button.

When steam cooking, the cooking time does not start until the heating up time has elapsed.



Once the cooking time has elapsed, the appliance switches off automatically.

1. Turn the operating mode selector back to the **o** position.
2. Press the clock function button to exit the clock function.

### End of operation

Automatic switch-off at a set time. This function is only possible for operating modes that do not use steam.

1. Set the operating mode and temperature. Press the Start button. The appliance heats up.
2. Press the clock function button repeatedly until the and symbols light up.
3. Set the end of operation using the rotary selector (e.g. **12:30** o'clock). The setting is applied automatically. The clock is then displayed again.



The appliance switches off automatically at the time set for the end of operation.

1. Turn the operating mode selector back to the **o** position.
2. Press the clock function button to exit the clock function.





## Preset operation

The appliance switches on automatically, then switches off automatically at the time preselected for the end of operation.

Bear in mind that food that spoils easily must not stay in the cooking compartment for too long.

Preselection mode is not possible with some of the automatic programmes.

When  Steam cooking, the cooking time does not start until the heating up time has elapsed. The end of operation which was set is therefore delayed by the length of time required for heating-up.

1. Set the operating mode and temperature.
2. Press the clock function button repeatedly until the  and  symbols light up.
3. Set the cooking time with the rotary selector (e.g. **1:30** hours).
4. Press the clock function button repeatedly until the  and  symbols light up.
5. Set the end of operation using the rotary selector (e.g. **12:30**).
6. Press the Start button.



The appliance waits until the appropriate time to switch on (in the example at **11:00**).

The appliance switches off automatically at the time set for the end of operation (**12:30**). A signal sounds and the  symbol flashes.

1. Turn the operating mode selector back to the  position.
2. Press the clock function button to end the preselection mode.

## Setting the clock

You can only change the clock when no other clock function is active.

1. Press the  clock function button repeatedly until the  and  symbols light up.
2. Set the clock using the rotary selector.  
The setting is applied automatically.

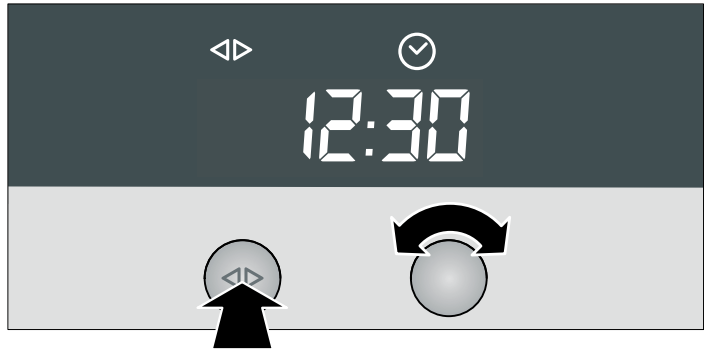

## Checking, correcting or deleting settings

1. To check your settings, press the  clock function button repeatedly until the corresponding symbol lights up.
2. If necessary, you can correct your setting using the rotary selector.
3. If you wish to cancel your setting, turn the rotary selector anti-clockwise to the original value.

## Automatic programmes

You can prepare food really easily with 40 different programmes.

In this section, you will find out

- how to set one of the automatic programmes
- hints and tips on the programmes
- which programmes you can set

### Setting a programme

Select the appropriate programme from the programme table. Follow the instructions for the programmes.

1. Press on the operating mode selector to turn on the appliance.
2. Press the  button.  
The first programme **P:01** appears on the temperature display.
3. Select the programme with the temperature selector.



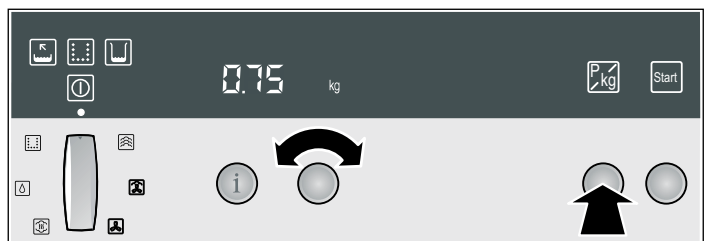

4. Press the  button again.  
A default weight appears on the temperature display.  
For some programmes, you do not have to enter a weight. In such cases, no default weight is displayed.
5. Turn the temperature selector to set the weight.



6. Press the Start button.  
No heating indicator appears.

### Checking the cooking time

Press the clock function button  repeatedly until the  and  symbols light up.

### Programme with preselected mode

For some programmes, you can set a  Preselection mode. The programme will be started later and finish at the desired time (see Section: Electronic clock).

### Cancelling the programme

Press and hold the Stop button.

### End of the programme

An audible signal sounds. Cooking has finished. To turn off the appliance, press in the operating mode selector so that it clicks into place.

### Risk of scalding!

Hot steam may escape when the appliance door is opened. Open the appliance door carefully during or after cooking. When opening the door, do not lean over it. Ensure that, depending on the temperature, steam is not visible.

## Notes about the programmes

All programmes are designed for cooking on one level.

The cooking result can vary according to the size and quality of the food.

### Ovenware

Use the suggested ovenware. All meals have been tested using this ovenware. The cooking result may change if you use different ovenware.

When cooking in the perforated cooking container, also insert the solid cooking container at level 1. Dripping liquid is caught.

### Amount/weight

Do not fill the food more than 4 cm deep in the accessories.

The automatic programmes require the weight of the food. With individual pieces, always enter the weight of the largest. The total weight must be within the specified weight range.

### Cooking time

After the programme is started the cooking time is displayed. It may change during the first 10 minutes, as the heating-up time depends, among other things, on the temperature of the food and the water.

### Preparing vegetables P1 - P8

Do not season vegetables until after cooking.

### Preparing rice P9 - P 10

Weigh the rice and add to the water in a ratio of 1:1.5. Enter the weight excluding liquid. Stir the rice after cooking. The remaining water is then quickly absorbed.

### Cook poultry P 11 - P 13

Do not place chicken breasts or chicken portions on top of each other in the ovenware. The chicken portions can be marinated beforehand.

### Cook sirloin at low temperature P 15

With sirloin, it is recommended that you use a thick piece. Sear the meat well beforehand.

### Slow-cooked leg of lamb P 19

Sear the meat well beforehand.

### Steam fish P 21 - P 22

When preparing fish, grease the perforated cooking container.

Do not place whole fish or fish fillets on top of each other. Enter the weight of the heaviest fish and choose pieces as similar in size as possible.

### Bake plaited loaf P 24

Leave the yeast dough to prove in the combination steam oven for half an hour in Steam cooking mode at 40 °C.

### Prepare rice pudding P 25

Weigh the rice and add 2.5 times the amount of milk. Ensure the amount of rice and milk in the accessory is no deeper than 2.5 cm. Stir after cooking. The remaining milk is quickly absorbed.

### Prepare yoghurt P 26

Heat the milk to 90 °C on the hob. Then leave to cool to 40 °C. If you are using UHT milk, you do not need to heat it.

Stir in one to two teaspoons of natural yoghurt per 100 ml milk, or the corresponding amount of yoghurt culture into the milk. Pour the mixture into clean jars and seal them.

After preparation, leave the glass jars to cool in the refrigerator.

### Bake bread P 27 - P 28

The programmes are designed for baking loaves of bread without a tin. The dough should not be too soft. Cut into the dough several times with a sharp knife to a depth of approx. 1 cm before baking.

### Bake bread rolls P 29

The bread rolls should all be the same weight. Enter the weight of an individual bread roll.

### Defrost P 35 - P 37

When freezing, lay the food as flat as possible and in portion-sized pieces at -18 °C. Do not freeze excessively large quantities. Once defrosted, food will not keep for as long and spoils more quickly than fresh food.

Leave the food to defrost in the freezer bag, on a plate or on the perforated cooking container. Always insert the baking tray underneath. The food is then not left lying in the defrost water and the cooking compartment remains clean.

All defrost programmes apply to raw food.

If necessary, the food can occasionally be split apart or pieces which have already defrosted can be removed from the appliance.

After defrosting, allow the food to stand for a further 5 - 15 minutes to come up to room temperature.

### Health risk!

When defrosting food from animal sources, you must remove the liquid that escapes during defrosting. It must never come into contact with other food. Bacteria could be transferred. After defrosting, operate the combination steam oven for 15 minutes using Hot air at 180 °C.

Defrosting fish fillets (P 35): Never place the fish fillets on top of each other.

Defrosting whole poultry (P 36): Remove the packaging before defrosting. Leave the poultry to stand after defrosting. With large poultry (e.g. small turkeys), you can remove the giblets after approximately 30 minutes standing time.

### Disinfect bottles P 38

Always clean baby bottles with a bottle brush immediately after feeding. Then clean them in the dishwasher.

Place the bottles in the perforated cooking container so that they do not touch one another.

Dry the bottles with a clean cloth after disinfecting. The process corresponds to normal sterilisation by boiling.

### Preserve P 39

This programme is suitable for fruits with a stone or core and for vegetables (except beans).

Blanch pumpkin before preserving.

The programme is designed for 1 litre jars.

After the end of the programme, open the appliance door to prevent cooking from continuing. Leave the jars to cool down for a few minutes in the cooking compartment.

### Cook eggs P 40

Pierce the eggs before cooking. Do not place eggs on top of each other. Size M corresponds to a unit weight of approx. 50 g.

## Programme table

This section contains all your combination steam oven programmes. Follow the instructions for the programmes.

Programme	Notes	Accessories	Level
<i>P 1*</i> Steam cauliflower florets	florets of equal size	Perforated cooking container + Baking tray	3 1
<i>P 2*</i> Steam broccoli florets	florets of equal size	Perforated cooking container + Baking tray	3 1
<i>P 3*</i> Steam green beans	-	Perforated cooking container + Baking tray	3 1
<i>P 4*</i> Steam sliced carrots	slices, approx. 3 mm thick	Perforated cooking container + Baking tray	3 1
<i>P 5*</i> Steam white asparagus	-	Perforated cooking container + Baking tray	3 1
<i>P 6</i> Steam frozen mixed vegetables	-	Perforated cooking container + Baking tray	3 1
<i>P 7*</i> Boiled potatoes	medium-sized, quartered, 30 - 40 g each	Perforated cooking container + Baking tray	3 1
<i>P 8*</i> Unpeeled boiled potatoes	medium-sized, dia. 4 - 5 cm	Perforated cooking container + Baking tray	3 1
<i>P 9</i> Long grain rice	max. 0.75 kg	Solid cooking container	2
<i>P 10</i> Basmati rice	max. 0.75 kg	Solid cooking container	2
<i>P 11</i> Fresh chicken	total weight 0.7 - 1.5 kg	Wire rack + baking tray	2
<i>P 12</i> Fresh chicken portions	0.04 - 0.35 kg each	Wire rack + baking tray	2
<i>P 13</i> Steam fresh chicken breast	total weight 0.2 - -1.5 kg	Perforated cooking container + Baking tray	3 1
<i>P 14*</i> Fresh pot roast	1 - 1.5 kg	Baking tray	2
<i>P 15</i> Cook fresh sirloin (medium) at low temperature	total weight 1 - 2 kg	Baking tray	2
<i>P 16*</i> Fresh lean joint of veal	1 - 2 kg	Wire rack + baking tray	2
<i>P 17*</i> Stuffed breast of veal	1 - 2 kg	Wire rack + baking tray	2
<i>P 18*</i> Fresh joint of pork (neck), boned	0.8 - 2 kg	Wire rack + baking tray	2
<i>P 19</i> Cook fresh leg of lamb (boned) at low temperature (medium)	1 - 2 kg	Baking tray	2
<i>P20</i> Meat loaf made from fresh minced meat	total weight 0.5 - 2 kg	Baking tray	2
<i>P21</i> Steam whole fresh fish	0.3 - 2 kg	Perforated cooking container + Baking tray	3 1
<i>P22</i> Steam fresh fish fillet	max. 2.5 cm thick	Perforated cooking container + Baking tray	3 1
<i>P23</i> Blue mussels	-	Perforated cooking container + Baking tray	3 1
<i>P24</i> Plaited loaf	0.6 - 1.8 kg	Baking tray + greaseproof paper	2
<i>P25</i> Rice pudding	-	Baking tray	2
<i>P26</i> Yogurt in glass jars	-	Jars + Perforated cooking container	2
<i>P27*</i> Bake multigrain bread	0.6 - 2 kg	Baking tray + greaseproof paper	2
<i>P28*</i> Bake rye bread	0.6 - 2 kg	Baking tray + greaseproof paper	2
<i>P29*</i> Bake fresh bread rolls	weight per piece 0.05 - 0.1 kg	Baking tray + greaseproof paper	2
<i>P30*</i> Reheat 1 portion	-	Wire rack	2
<i>P31*</i> Reheat cooked side dishes	-	Baking tray	2
<i>P32*</i> Reheat cooked vegetables	-	Baking tray	2
<i>P33*</i> Reheat cooked pizza (thin base)	-	Wire rack + baking tray	3
<i>P34*</i> Reheat cooked pizza (deep-pan base)	-	Wire rack + baking tray	3

\* You can set a preselection mode for this programme

Programme	Notes	Accessories	Level
P35	Defrost fish fillet	max. 2.5 cm thick	Perforated cooking container + 3 Baking tray 1
P36	Defrost whole poultry	max. 1.5 kg	Perforated cooking container + 3 Baking tray 1
P37	Defrost berries	-	Perforated cooking container + 3 Baking tray 1
P38*	Disinfect bottles	-	Perforated cooking container 2
P39	Preserve	in 1 litre jars	Perforated cooking container + 3 Baking tray 1
P40*	Soft-boiled eggs	eggs, size M, max. 1 kg	Perforated cooking container + 3 Baking tray 1

\* You can set a preselection mode for this programme

## Childproof lock

In this section, you can read about

- how to lock your appliance
- how to lock your appliance permanently

### Lock

Once it has been locked, the appliance cannot be switched on accidentally or by unauthorised users (e.g. by children playing).

To switch the appliance on again, you must unlock it. After appliance operation, the appliance is not automatically locked. Lock it again if necessary or activate the permanent lock.

#### Locking the appliance

1. Switch on the appliance.
2. Press and hold the **i** info button until **c i** (Appliance unlocked) appears.
3. Turn the temperature selector until **c i i** (Appliance locked) appears.
4. Press and hold the **i** info button until the **↔** symbol appears.

**Note:** If you try to switch the locked appliance on, **-S-** (Appliance locked) appears.

#### Unlocking the appliance

1. Press and hold the **i** info button until **c i i** (Appliance locked) appears.
2. Turn the temperature selector until **c i** (Appliance unlocked) appears.
3. Press and hold the **i** info button until the **↔** symbol goes out.

### Permanent lock

Once it has been permanently locked, the appliance cannot be switched on accidentally or by unauthorised users (e.g. by children playing).

To switch the appliance on, you must interrupt the permanent lock briefly. After you have switched your appliance off, it locks again automatically.

#### Locking the appliance permanently

1. Switch on the appliance.
2. Press and hold the **i** info button until **c i** (Appliance locked) appears.
3. Turn the temperature selector until **c 2 i** (Appliance permanently locked) appears.
4. Press and hold the **i** info button for 3 seconds. Your appliance will be locked after 30 seconds. The **↔** symbol appears.

**Note:** If you try to switch the locked appliance on, **-SP-** (Appliance permanently locked) appears.

#### Interrupting permanent lock

1. Press and hold the **i** info button until **c 2 i** (Appliance permanently locked) appears.
2. Turn the temperature selector until **c 2 0** (Appliance unlocked once) appears.
3. Press and hold the **i** info button until the **↔** symbol goes out. The permanent lock is interrupted.
4. Switch the appliance on within 30 seconds. After switching it off, the permanent lock is reactivated after 30 seconds.

#### Unlocking the appliance permanently

1. Press and hold the **i** info button until **c 2 i** (Appliance permanently locked) appears.
2. Turn the temperature selector until **c 2 0** (Appliance unlocked once) appears.
3. Press and hold the **i** info button until the **↔** symbol goes out.
4. Within 30 seconds, press and hold the info button **i** again for 3 seconds.
5. Turn the temperature selector until **c i** (Appliance unlocked) appears.
6. Press and hold the **i** info button for 3 seconds. The appliance is permanently unlocked.



## Basic settings

Your appliance has various basic settings, which are preset at the factory. You can change the basic settings as you require.

If you want to cancel all the changes, you can restore the factory settings.

You can only change the basic settings if the appliance is switched on.

1. If required, turn the operating mode selector to **O**.
2. Press and hold the **i** information button until **c 10** (Lock is not activated) appears in the temperature display.
3. Briefly press the **i** information button repeatedly until the desired basic setting is displayed.
4. Use the temperature selector to change the basic setting.
5. Press and hold the **i** info button for 3 seconds. The change is saved.

You can change the following basic settings:

Basic settings menu		
Submenu	Basic setting	Setting symbol
Childproof lock	Lock is not activated	<b>c 10</b>
	Lock is activated	<b>c 11</b>
	Permanent lock is activated	<b>c 21</b>

\* Restore the appliance to the factory settings:

- all changes to the basic settings are cleared
- Automatic calibration is carried out again

Basic settings menu		
Submenu	Basic setting	Setting symbol
Audible signal	Audible signal off	<b>c 30</b>
	Audible signal duration 30 seconds	<b>c 31</b>
	Audible signal duration 2 minutes	<b>c 32</b>
Audible signal duration 10 minutes	Audible signal duration 10 minutes	<b>c 33</b>
Auto start	off	<b>c 40</b>
	on	<b>c 41</b>
Water hardness range	softened	<b>c 50</b>
	soft (I)	<b>c 51</b>
	medium (II)	<b>c 52</b>
	hard (III)	<b>c 53</b>
very hard (IV)	very hard (IV)	<b>c 54</b>
Steam heating up signal	off	<b>c 60</b>
	on	<b>c 61</b>
Factory settings*	Do not restore	<b>c 70</b>
	Restore	<b>c 71</b>

\* Restore the appliance to the factory settings:

- all changes to the basic settings are cleared
- Automatic calibration is carried out again

## Automatic safety cut-out

The automatic safety cut-out is only activated if you have not made any settings on your appliance for a prolonged period.

The length of time after which your appliance switches itself off depends on the settings that you make.

**000** flashes in the temperature display. Cooking is interrupted.

Turn the operating mode selector back to the **O** position to deactivate the automatic safety switch-off function. You can now make new settings.

## Care and cleaning

In this section, you will find information on

- Care and cleaning of your appliance
- Oven cleaning aid EasyClean®
- Descaling

### Risk of short circuit!

Do not use high-pressure cleaners or steam jet cleaners to clean your appliance.

### Caution!

Risk of surface damage: Do not use

- harsh or abrasive cleaning agents
- oven cleaners
- corrosive or aggressive cleaners, or those containing chlorine
- cleaning agents with a high alcohol content

If such an agent comes into contact with the front of the appliance, wash it off immediately with water.

**Caution!**

Risk of surface damage: If descaler or the oven and grill cleaning gel comes into contact with the front of the appliance or other sensitive surfaces, wash it off immediately with water.

Remove food residues from the cooking compartment as soon as the appliance has cooled. Burnt-on remains will be much harder to remove later.

For heavy soiling use the cleaning aid (see section: Cleaning aid EasyClean®).

Salts are very corrosive and can cause rust. Remove remains of acidic sauces (ketchup, mustard) or salted food from the cooking compartment immediately after cooling.

Do not use hard scouring pads or cleaning sponges.

**Cleaning agents**

Appliance exterior (with aluminium front)	Use soapy water and dry with a soft cloth. Mild window cleaning agent – wipe the aluminium front horizontally and without applying pressure using a soft window cloth or a lint-free microfibre cloth
Appliance exterior (with stainless-steel front)	Use soapy water and dry with a soft cloth. Always remove any flecks of limescale, grease, starch and albumin (e.g. egg white) immediately. Special stainless steel cleaning agents can be obtained from the after-sales service or from specialist retailers
Cooking compartment interior with evaporator dish	Hot, soapy water or a vinegar solution – use the enclosed cleaning sponge or a soft dish brush.  <b>Caution!</b> The cooking compartment could rust.: Do not use steel pads or scourers. If the cooking compartment is very dirty, use only the oven and grill cleaning gel recommended by the after-sales service (product no. 463 582, also available online in the eShop). Follow the manufacturers instructions. Other oven cleaners could damage the appliance. The cooking compartment light and the seals around the door, light and evaporator dish must not come into contact with the gel. Allow the gel to act for a maximum of 12 hours and do not switch on the appliance during this time. Then rinse the cooking compartment thoroughly with water (e.g. with a spray bottle) to remove all traces of the gel
Water tank	Soapy water – do not clean in the dishwasher.
Tank recess	Rub dry after every use
Seal in the water tank lid	Thoroughly dry after every use
Rails	See section: Cleaning the rails
Door panels	See section: Cleaning the door panels  <b>Caution!</b> Risk of surface damage: After cleaning, wipe the door panels with glass cleaner, then dry. Otherwise, stains will be caused that will not be able to be removed.
Door seal	Hot soapy water
Accessories	Soak in hot soapy water. Clean with a washing-up brush or sponge, or in the dishwasher.  Clean stains caused by starchy food (e.g. rice) with a vinegar solution

**Cleaning sponge**

The enclosed cleaning sponge is very absorbent. Use the cleaning sponge only for cleaning the cooking compartment and for removing residual water from the evaporator dish.

Wash the cleaning sponge thoroughly before using for the first time. You can wash the cleaning sponge in the washing machine (hot wash).

**Microfibre cloth**

The honeycomb microfibre cloth is particularly suitable for cleaning sensitive surfaces such as glass, glass ceramic, stainless steel or aluminium (product no. 460 770, also available from our online eShop). It removes liquid and greasy deposits in one go.

**Roasting set**

If possible use the roasting set when roasting (ordering no. Z1684X3, also available online in the eShop). This considerably reduces the amount of spatter from the roast and therefore the amount of soiling in the cooking compartment.

**Oven cleaning aid**

The cleaning aid loosens dirt in the cooking compartment using steam. It can then be removed easily.

The cleaning process consists of:

- Cleaning (approx. 30 minutes), then empty the evaporator dish and wipe out the appliance
- 1st rinse (20 seconds), then empty the evaporator dish
- 2nd rinse (20 seconds), then remove the remaining water

All three steps must be completed in full. The appliance is ready for operation again only after the 2nd rinse.

**Preparation**

Allow the cooking compartment to cool down and remove the accessories. Clean the evaporator dish with the enclosed cleaning sponge.

Put a drop of washing-up liquid into the evaporator dish on the cooking compartment floor.

## Starting the cleaning aid

1. Press the operating mode selector to make it pop out.  
The appliance switches on.
2. Turn the operating mode selector to  EasyClean®.
3. Fill the water tank with water up to the "max" mark and slide it in.
4. Press the Start button.  
The cleaning aid starts running. The light in the cooking compartment remains switched off. **ELS** appears in the temperature display.

## Emptying the evaporator dish and wiping out the appliance

A signal sounds after approx. 30 minutes. The  (Empty evaporator dish) symbol and **I→: 00:40** min appear.

1. Open the appliance door.
2. Take the rails out of the cooking compartment and clean them (see section: Cleaning the rails).
3. Wipe out all loosened food residues from the cooking compartment and the evaporator dish using a soft washing-up brush and the cleaning sponge.
4. If required, fill the water tank with water and reinsert it.
5. Close the appliance door.

### 1st rinse

Press the Start button.  
The appliance starts rinsing.

### Empty evaporator dish

 (Empty evaporator dish) and **I→ 00:20** min appear after 20 seconds.

1. Open the appliance door.
2. Thoroughly rinse out the cleaning sponge.
3. Remove the remaining water from the evaporator dish using the cleaning sponge.
4. Close the appliance door.

### 2nd rinse

Press the Start button.  
The appliance starts rinsing.

## Removing the remaining water

After 20 seconds,  (Empty evaporator dish) and **00:00** appear.

1. Open the appliance door.
2. Remove the remaining water from the evaporator dish using the cleaning sponge.
3. Wipe out the cooking compartment using the cleaning sponge and then dry with a soft cloth.
4. Turn the operating mode selector back to **O**.
5. To turn off the appliance, press in the operating mode selector so that it clicks into place.

The cleaning aid is complete.

## Cancelling the cleaning aid

**Note:** After cancelling the cleaning aid, the appliance must be rinsed twice. The appliance is locked against other applications until the second rinsing operation is complete.

1. Press and hold the Stop button to cancel the Cleaning aid.  
**I→ 00:40** min appears in the clock display.  
To ensure that no washing-up liquid remains in the appliance, it must be rinsed twice after a cancellation.
2. Press the Start button.  
The  symbol (empty evaporator dish) appears.
3. If required, fill the water tank with water, reinsert it and press the Start button.

Now proceed as described in the section "Emptying the evaporator dish and wiping out the appliance".

## Descaling

The appliance must be descaled at regular intervals in order for it to continue operating correctly. The  indicator reminds you to do this.

You can only dispense with descaling completely if you exclusively use softened water.

The descaling operation consists of:

- Descale (approx. 30 minutes), then refill the water tank and empty the evaporator dish
- 1st rinse (20 seconds), then empty the evaporator dish
- 2nd rinse (20 seconds), then remove the remaining water

All three steps must be completed in full. The appliance is ready for operation again only after the 2nd rinse.

## Descaler

Only use the liquid descaler recommended by the after-sales service for descaling (product no. 311 138, also available online from the eShop). Other descalers may damage the appliance.

1. Prepare a descaling solution by mixing 300 ml water and 60 ml liquid descaler.
2. Empty the water tank and fill with descaling solution.

### Caution!

Risk of surface damage: If descaler comes into contact with the front of the appliance or any other sensitive surfaces, wash it off immediately with water.

## Starting descaling

The cooking compartment must have cooled down completely.

1. Press the operating mode selector to make it pop out.  
The appliance switches on.
2. Turn the operating mode selector to  Descal.
3. Slide in the water tank containing the descaling solution and close the appliance door.
4. Press the Start button.  
The descaling process starts. The light in the cooking compartment remains switched off.

## Emptying the evaporator dish and refilling the water tank



A signal sounds after approx. 30 minutes. The  symbol (Fill water tank) and **I→ 00:40** min are displayed.

1. Open the appliance door.
2. Rinse the water tank thoroughly, fill with water and reinsert.  
The  symbol (empty evaporator dish) appears.
3. Remove the descaling solution from the evaporator dish using the cleaning sponge provided.
4. Close the appliance door.

### 1st rinse

Press the Start button.  
The appliance starts rinsing.

### Empty evaporator dish

 (Empty evaporator dish) and  00:20 min appear after 20 seconds.

1. Open the appliance door.
2. Thoroughly rinse out the cleaning sponge.
3. Remove the remaining water from the evaporator dish using the cleaning sponge.
4. Close the appliance door.

### 2nd rinse

Press the Start button.  
The appliance starts rinsing.

### Removing the remaining water

After 20 seconds,  (Empty evaporator dish) appears.



1. Open the appliance door.
2. Remove the remaining water from the evaporator dish using the cleaning sponge.
3. Wipe out the cooking compartment using the cleaning sponge and then dry with a soft cloth.
4. Turn the operating mode selector back to .
5. To turn off the appliance, press in the operating mode selector so that it clicks into place.

Descaling is complete.

### Cancelling descaling

**Note:** After cancelling, the appliance must be rinsed twice. The appliance is locked against other applications until the second rinsing operation is complete.

Press and hold the Stop button to cancel the descaling process.

The  symbol (Fill water tank) and  00:40 min are displayed.

To ensure that no descaling solution remains in the appliance, it must be rinsed twice after a cancellation.

Now proceed as described in the section: "Emptying the evaporator dish and refilling the water tank".

### Descaling the evaporator dish only

You can also use "Descal" if you do not wish to descale the whole appliance, but only the evaporator dish in the cooking compartment.

The only difference is as follows:

1. Prepare a descaling solution by mixing 100 ml water and 20 ml liquid descaler.
2. Completely fill the evaporator dish with descaling solution.
3. Fill the water tank with water only.
4. Start "Descal" as described.

You can also descale the evaporator dish manually.

### Removing and fitting the appliance door

You can remove the appliance door to clean it more thoroughly.

#### Risk of injury!

The hinges of the appliance door may snap shut with great force. Always open the hinge locking lever fully when removing the appliance door and close it fully after refitting. Do not reach into the hinge.

#### Risk of injury!

If the appliance door has only been unhinged on one side, do not reach into the hinge. The hinge can snap back with great force. Call the after-sales service.

### Removing the appliance door

1. Open the appliance door fully.
2. Fold out the locking levers on the left and right fully (figure A). The hinges are secured and cannot snap closed.
3. Close the appliance door until you feel some resistance.
4. With both hands, grip the door on the left and right-hand side, close the door a little more and pull it out (Fig. B).

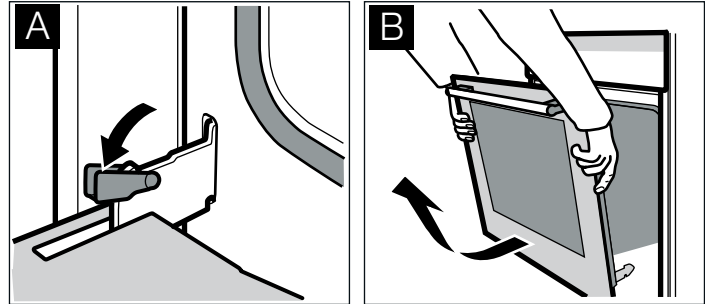

### Fitting the appliance door

Refit the appliance door after cleaning.

1. Insert the hinges in the left and right-hand bracket (figure C). The notch on both hinges must engage.
2. Open the appliance door fully.
3. Close the locking levers on the left and right-hand side fully (figure D).

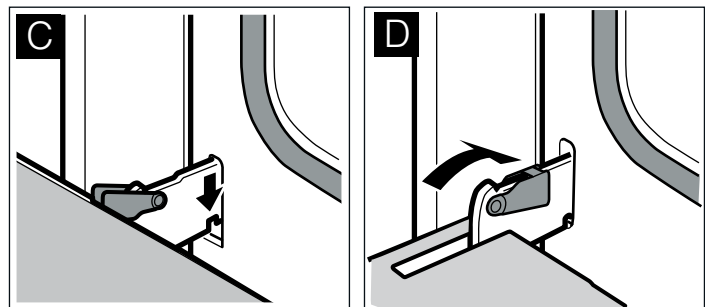

The appliance door is secured and can no longer be removed.

4. Close the appliance door.

### Cleaning the door panels

To facilitate cleaning, you can remove the door panels from the appliance door.

#### Risk of injury!

The components inside the appliance door may have sharp edges. Take care not to cut yourself. Wear protective gloves.

#### Risk of injury!

The appliance must not be used again until the door panels and appliance door have been correctly fitted.

### Removing the door panel

**Note:** Before removing, make a note of the orientation in which the door panel is fitted, so that it is not refitted the wrong way round.

1. Unhook the appliance door and lay it on a soft, clean surface with the front side facing downwards (see section: Removing and installing the appliance door).
2. Unscrew the cover at the top left and right of the appliance door and detach it (figure A).
3. Lift the door panel and remove it (figure B).

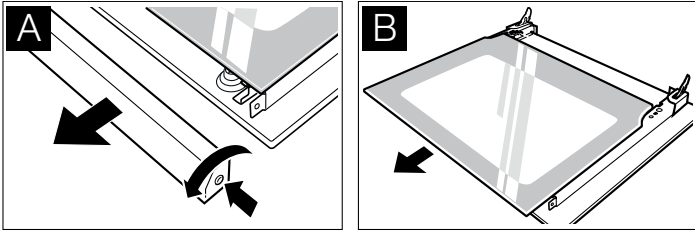

### Removing the intermediate panel

Before removing, make a note of the position in which the intermediate panel is fitted, so that you do not refit it the wrong way round later.

1. Press the left and right-hand holders outwards.
2. Lift the intermediate panel slightly and take it out.

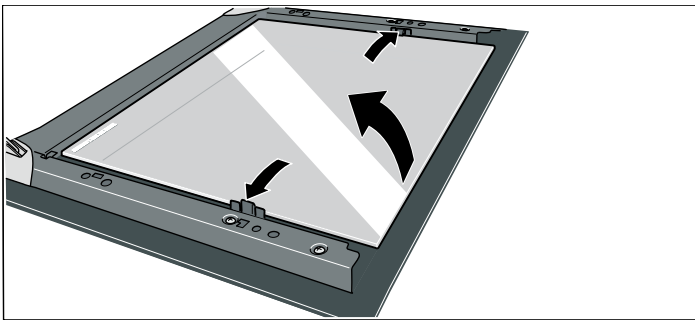

### Cleaning

Clean the door panels with glass cleaner and a soft cloth.

#### Caution!

Do not use any sharp or abrasive medium or a glass scraper. The glass could be damaged.

### Fitting the intermediate panel

1. Insert the intermediate panel on the left and right into the supports.
2. Push the intermediate panel downwards in the retainers.

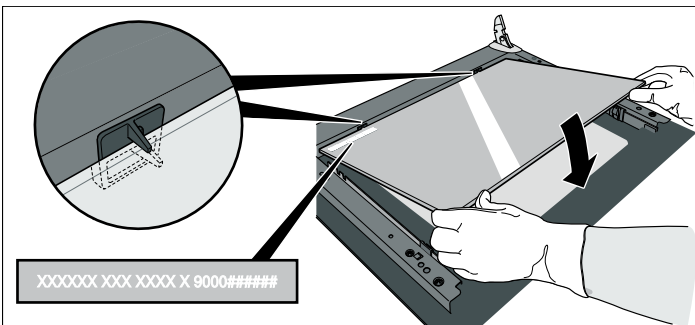

### Fitting the door panel

1. Slide in the door panel all the way.
2. Put the cover back in place and screw it in.
3. Refit the appliance door.

### Cleaning the rails

The rails can be removed for cleaning.

**⚠ Risk of burning due to hot components in the cooking compartment!**

Wait until the cooking compartment has cooled down.

### Detaching the rails

**Note:** Swing the front of the rail as far as possible (until you feel resistance), because otherwise the appliance side panel may become bent.

1. Carefully press the front of the rail upwards until it becomes detached, and release it from the holder at the side (fig. A).
2. Detach the rail from the holder and remove it (fig. B).

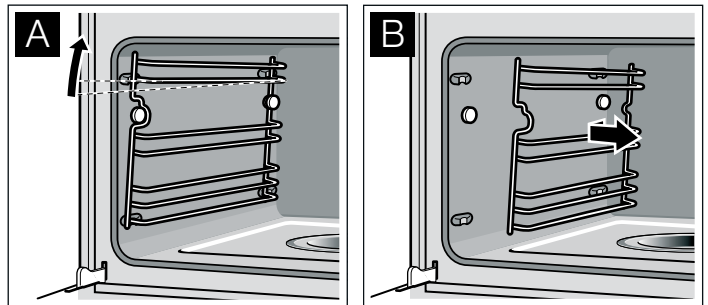

3. Clean the rails with washing-up liquid and a sponge/brush or  
Clean the rails in the dishwasher.

### Attaching the rail

1. Position the rail so that the indentations are facing upwards.
2. Hook the rail in at the back and push it towards the rear until it engages (fig. C).
3. Hook the front of the rail onto the holder and press down until it engages and is fixed level in place in the appliance once more (fig. D).

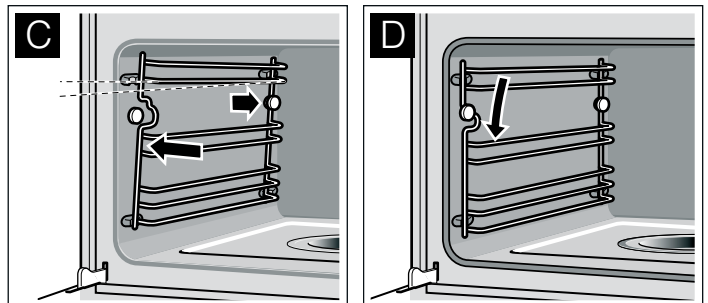

Each set of rails only fits on one side.

# Troubleshooting





Malfunctions often have simple explanations. Please read the following instructions before calling the after-sales service.

Repairs may only be carried out by fully trained after-sales service technicians. Incorrect repairs to your appliance may present considerable risks for the user.

## Risk of electric shock!

- Work on the appliance electronics may only be performed by a specialist.
- Always disconnect the appliance from the power supply when work is carried out on the electronics. Switch off the circuit breaker or remove the fuse from your household fuse box.

Problem	Possible cause	Notes/remedy
The appliance does not work	The plug is not plugged in	Connect the appliance to the electricity supply
	Power cut	Check whether other kitchen appliances are working
	Circuit-breaker faulty	Check in the fuse box to make sure that the circuit-breaker for the appliance is OK
	Faulty operation	Switch off the circuit-breaker for the appliance in the fuse box and switch it back on after approx. 10 seconds
The appliance cannot be started	The appliance door is not fully closed	Close the appliance door
	The appliance is not switched off	Turn the operating mode selector back to the 0 position and switch on again.
The appliance cannot be started, I→I and 00:40 min appear in the clock display	Cleaning aid or descaling was cancelled	Turn the operating mode selector to the  EasyClean® cleaning aid or  Descal, and rinse the appliance twice (see the section: Cancelling the cleaning aid or cancelling descaling)
0:00 flashes in the clock display	Power cut	Reset the clock (see section: Electronic clock)
0:00 flashes in the clock display, rrr appears in the temperature display	Power cut during cooking	Press the  clock function button, reset the clock (see section: Electronic clock)
The appliance is not in operation. A cooking time is shown in the clock display	The Start button was not pressed after the setting had been made	Press the Start button or delete the setting with the Stop button
000 flashes in the temperature display	Automatic safety cut-out is active	Turn the operating mode selector back to 0 and lock it in place
	The appliance is not switched off	Turn the operating mode selector back to 0 and lock it in place
The  indicator appears even though the water tank is full	The water tank has not been inserted properly	Push in the water tank until it locks into place.
	The detection system is not working	Call the after-sales service
The  indicator appears even though the water tank is not yet empty or the water tank is empty, but the  indicator does not appear	The water tank is dirty. The moving water level indicators are jammed	Shake and clean the water tank. If the parts cannot be freed, obtain a new water tank from the after-sales service
The water tank empties for no discernible reason. The evaporator dish overflows	The water tank was not closed properly	Close the lid until you feel it lock into place
	The tank lid seal is dirty	Clean the seal
	The tank lid seal is faulty	Obtain a new water tank from the after-sales service
The evaporator dish has boiled empty even though the water tank is full.	The water tank has not been inserted properly	Push in the water tank until it locks into place
	The feed line is blocked	Descal the appliance. Check whether the water hardness range is set correctly
The  indicator appears	The appliance has not been used for at least two days and the water tank is full	Empty and clean the water tank. Always empty the water tank after cooking
There is a "pop" noise during cooking	Cold/warm effect with frozen food, caused by the steam	This is normal
When you cook with steam, a lot of steam is created	The appliance is being automatically calibrated	This is normal

Problem	Possible cause	Notes/remedy
When cooking with steam, a great deal of steam is created again	The appliance is unable to calibrate itself automatically if cooking times are too short	Restore the appliance to the factory setting (see section: Basic settings). Then start  Steam cooking at 100 °C for 20 minutes
Steam escapes from the ventilation slots during cooking		This is normal
The appliance is not producing steam properly	Limescale has formed in the appliance	Descale the appliance (see section: Descaling).
The error message <b>E0 11</b> appears in the temperature display	A button was pressed for too long or is jammed	Press the  clock function button to delete the error message. Press all of the buttons individually and check if they are clean
An <b>E0...</b> error message appears in the temperature display	Technical fault	Press the  clock function button to delete the error message, and reset the clock if necessary. If the error message appears again, call the after-sales service
The appliance is no longer heating. The colon is flashing in the clock display. For example, <b>1000</b> appears in the temperature display	A button combination was actuated	Switch off the appliance. Press the <b>i</b> information button for 3 seconds, then press the  clock function button for 4 seconds and then press the <b>i</b> information button again for another 3 seconds

## Replacing the cooking compartment bulb

Heat-resistant 230 V/25 W halogen bulbs with seals are available from the after-sales service. Please specify the E number and FD number of your appliance.

### Risk of burns!

Allow the cooking compartment and cooking compartment light to cool before changing the bulb.

Always use a dry cloth to remove a new halogen bulb from the packaging, otherwise it will not last as long.

1. Switch off the fuse in the fuse box or unplug at the mains.
2. Turn the cover anti-clockwise to remove.
3. Remove the bulb and replace with a bulb of the same type.
4. Slide the new seals and the clamping ring onto the glass cover in the right order.

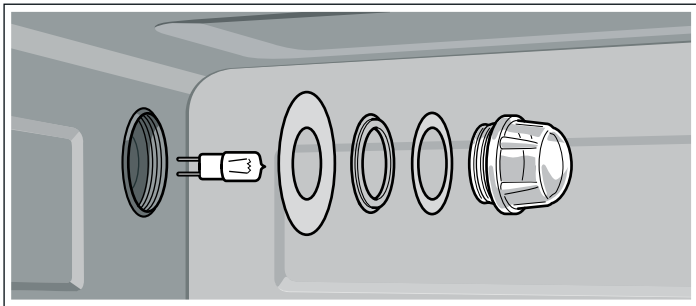

5. Screw the glass cover with the seals back on again.
  6. Connect the appliance to the mains and reset the clock.
- Never operate the appliance without the glass cover and seals.

### Replacing the glass cover or seals

Any damaged glass cover or seals must be replaced. Please provide the after-sales service with the E number and FD number of your appliance.

## Changing the door seal

If the seal around the outside of the cooking compartment is faulty, it must be replaced. Replacement seals for your appliance can be obtained from the after-sales service. Please specify the E number and FD number of your appliance.

1. Open the appliance door.
2. Pull off the old seal.
3. Push in the new door seal at one point and pull it in all the way round. The joint must be at the side.
4. Check again that the seal is correctly fitted in the corners.

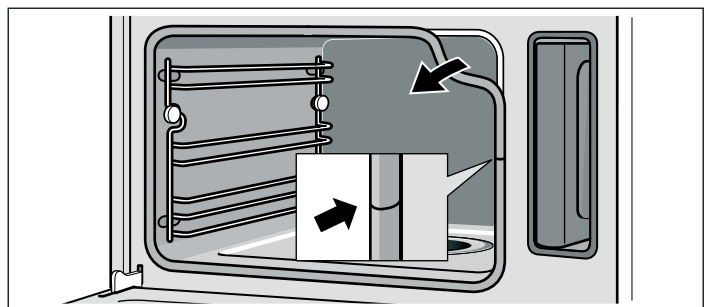

# After-sales service

Our after-sales service is there for you if your appliance needs to be repaired. We will always find the right solution in order to avoid unnecessary visits from a service technician.

## E number and FD number

When calling us, please give the product number (E no.) and the production number (FD no.) so that we can provide you with the correct advice. The rating plate bearing these numbers can be found on the lower left-hand side when you open the appliance door.

You can make a note of the numbers of your appliance and the telephone number of the after-sales service in the space below to save time should it be required.

---

E no.	FD no.
-------	--------

---

---

## After-sales service

---

Please note that there will be a fee for a visit by a service technician in the event of a malfunction, even during the warranty period.

Please find the contact data of all countries in the enclosed customer service list.

### To book an engineer visit and product advice

**GB** 0844 8928989

Calls from a BT landline will be charged at up to 3 pence per minute. A call set-up fee of up to 6 pence may apply.

**IE** 01450 2655

Trust the expertise of the manufacturer, and rest assured that the repair will be carried out by trained service technicians using original spare parts for your domestic appliance.

---

# Environmental protection

## Environmentally-friendly disposal

Dispose of packaging in an environmentally-friendly manner.



This appliance is labelled in accordance with European Directive 2012/19/EU concerning used electrical and electronic appliances (waste electrical and electronic equipment - WEEE). The guideline determines the framework for the return and recycling of used appliances as applicable throughout the EU.

## Tips for saving energy

- Only preheat the appliance if this is specified in the recipe or in the operating instructions table.
- Open the appliance door as infrequently as possible while the food is cooking.
- Use dark, black lacquered or enamelled baking tins for baking. They absorb the heat particularly well.
- It is best to bake several cakes one after the other. The combination steam oven will still be hot. This reduces the baking time for the second cake. You can also place two loaf tins next to each other.
- If the cooking time is relatively long, you can switch off the combination steam oven 10 minutes before the end of the cooking time and use the oven's residual heat to complete the cooking process.
- When steaming, you can cook on several levels at the same time. When preparing foods with different cooking times, those with the longest cooking time should be placed in the oven first.



## Tables and tips

The tables contain a selection of dishes which are particularly suitable for your combination steam oven. You can find out which operating mode, accessories and cooking time to select. Unless otherwise stated, the information given applies to inserting accessories when the appliance is cold.

### Accessories

Use the accessories provided.

When steaming in the perforated cooking container, always insert the baking tray underneath. Dripping liquid is caught.

### Ovenware

When using ovenware, always place it in the middle of the wire rack.

Ovenware must be heat and steam resistant. Cooking times are increased if thick-sided ovenware is used.

Food which would normally be prepared in a bain-marie should always be covered with foil (e.g. when melting chocolate).

## Steam cooking

Steaming is a particularly gentle way of cooking food. The steam surrounds the dish thereby preventing a loss of nutrients from the food. Cooking takes place without excess pressure. As a result, the shape, colour and typical aroma of the dishes are retained.

### Cooking times and quantities

The cooking times when steaming depend on the item size, but do not depend on the total quantity. The appliance can steam food to a maximum of 2 kg.

Follow the unit sizes given in the tables. The cooking time is reduced for smaller pieces and increased for larger ones. Cooking time is also influenced by the quality and ripeness of the food. The values quoted can therefore only serve as a guideline.

## Vegetables

Place the vegetables in the perforated cooking container and insert at level 3. Insert the baking tray underneath at level 1. Dripping liquid is caught.

Food	Size	Accessories	Operating mode	Temperature in °C	Cooking time in min.
Artichokes	whole	Perforated + baking tray	Steam cooking	100	30 - 35
Cauliflower	whole	Perforated + baking tray	Steam cooking	100	30 - 40
Cauliflower	Florets	Perforated + baking tray	Steam cooking	100	10 - 15
Broccoli	Florets	Perforated + baking tray	Steam cooking	100	8 - 10
Peas	-	Perforated + baking tray	Steam cooking	100	5 - 10
Fennel	Slices	Perforated + baking tray	Steam cooking	100	10 - 14
Stuffed vegetables (courgettes, aubergines, peppers)	Do not pre-cook vegetables	Baking tray at level 2	CircoSteam®	160 - 180	15 - 30
Vegetable flan	-	1.5 l bain-marie dish + wire rack at level 2	Steam cooking	100	50 - 70
Green beans	-	Perforated + baking tray	Steam cooking	100	15 - 20
Carrots	Slices	Perforated + baking tray	Steam cooking	100	10 - 20
Kohlrabi	Slices	Perforated + baking tray	Steam cooking	100	15 - 20

\* Preheat the appliance

### Distributing food evenly

Always distribute the food evenly in the ovenware. It will not cook evenly if the layers are of different depths.

### Pressure-sensitive food

When layering delicate foods in the cooking container, do not pile them too high. It is better to use two containers.

### Cooking a menu

With steam, you can cook a whole menu at once, without the different flavours mixing. Place the food with the longest cooking time in the appliance first and delay the rest until the appropriate time. This means that all the food will be ready at the same time.

The overall cooking time is extended with menu cooking, as a little steam escapes each time the appliance door is opened and has to be reheated.

## Hot air

The Hot Air operating mode is ideal for sweet and savoury baking, pot roasts and various cakes.

## CircoSteam®

The CircoSteam® operating mode uses a combination of hot air and steam, and is particularly suitable for the preparation of roast dishes, chicken and baked items such as yeast-risen pastry and bread.

Roasts and chicken are nice and crisp on the outside and juicy inside. What is more, meat loses less of its weight.

Baked items, such as yeast-risen pastry and bread, take on a particularly attractive surface shine and they do not dry out.

Food	Size	Accessories	Operating mode	Temperature in °C	Cooking time in min.
Leeks	Slices	Perforated + baking tray	Steam cooking	100	4 - 6
Sweetcorn	whole	Perforated + baking tray	Steam cooking	100	25 - 35
Swiss chard*	Shredded	Perforated + baking tray	Steam cooking	100	8 - 10
Green asparagus*	whole	Perforated + baking tray	Steam cooking	100	7 - 12
White asparagus*	whole	Perforated + baking tray	Steam cooking	100	10 - 15
Spinach*	-	Perforated + baking tray	Steam cooking	100	2 - 3
Romanesco	Florets	Perforated + baking tray	Steam cooking	100	8 - 10
Brussels sprouts	Florets	Perforated + baking tray	Steam cooking	100	20 - 30
Beetroot	Whole	Perforated + baking tray	Steam cooking	100	40 - 50
Red cabbage	shredded	Perforated + baking tray	Steam cooking	100	30 - 35
White cabbage	shredded	Perforated + baking tray	Steam cooking	100	25 - 35
Courgettes	Slices	Perforated + baking tray	Steam cooking	100	2 - 3
Mangetout	-	Perforated + baking tray	Steam cooking	100	8 - 12

\* Preheat the appliance

## Side dishes and pulses

Add water or liquid in the proportion specified. Example: 1:1.5 = for every 100 g of rice add 150 ml of liquid.

You may select any shelf position you wish for the solid cooking container.

Food	Ratio	Accessories	Level	Operating mode	Temperature in °C	Cooking time in min.
Unpeeled boiled potatoes (medium size)	-	Perforated + Baking tray	3 1	Steam cooking	100	35 - 45
Boiled potatoes (quartered)	-	Perforated + Baking tray	3 1	Steam cooking	100	20 - 25
Potato gratin	-	Baking tray	2	Hot air	170 - 180	35 - 45
Brown rice	1:1.5	Solid	-	Steam cooking	100	30 - 40
Long grain rice	1:1.5	Solid	-	Steam cooking	100	20 - 30
Basmati rice	1:1.5	Solid	-	Steam cooking	100	20 - 30
Parboiled rice	1:1.5	Solid	-	Steam cooking	100	15 - 20
Risotto	1:2	Solid	-	Steam cooking	100	30 - 35
Lentils	1:2	Solid	-	Steam cooking	100	30 - 45
Canellini beans, pre-softened	1:2	Solid	-	Steam cooking	100	65 - 75
Couscous	1:1	Solid	-	Steam cooking	100	6 - 10
Unripe spelt grain, coarse ground	1:2.5	Solid	-	Steam cooking	100	15 - 20
Millet, whole	1:2.5	Solid	-	Steam cooking	100	25 - 35
Wheat, whole	1:1	Solid	-	Steam cooking	100	60 - 70
Dumplings	-	Perforated + Baking tray	3 1	Steam cooking	95	20 - 25

## Poultry and meat

Insert the wire rack and baking tray together at the same level.

When the roast is cooked, switch off the combination steam oven and leave it to rest for a further 10 minutes with the door closed. This will keep the meat juicy.

Using the CircoSteam® operating mode, the meat remains particularly tender on the inside while crispy on the outside.

### Poultry

Food	Amount	Accessories	Level	Operating mode	Temperature in °C	Cooking time in min.
Chicken, whole	1.2 kg	Wire rack + baking tray	2	CircoSteam®	180 - 190	50 - 60
Chicken, halved	0.4 kg each	Wire rack + baking tray	2	CircoSteam®	180 - 190	35 - 45
Chicken breast	0.15 kg each	Perforated + Baking tray	3 1	Steam cooking	100	15 - 25
Chicken portions	0.12 kg each	Wire rack + baking tray	2	CircoSteam®	180 - 200	20 - 35
Duck, whole	2 kg	Wire rack + baking tray	2	CircoSteam®	170	60 - 80
				Hot air	210	15 - 20
Duck breast*	0.35 kg each	Wire rack + baking tray	2	CircoSteam®	170 - 180	10 - 15
Rolled turkey joint	1.5 kg	Wire rack + baking tray	2	CircoSteam®	150 - 160	70 - 90
Turkey breast	1 kg	Wire rack + baking tray	2	CircoSteam®	150 - 160	60 - 80

\* Sear first

### Beef

Food	Amount	Accessories	Level	Operating mode	Temperature in °C	Cooking time in min.
Pot-roasted beef*	1.5 kg	Wire rack + baking tray	2	Reheat	140 - 150	100 - 140
Fillet of beef, medium*	1 kg	Wire rack + baking tray	2	Reheat	170 - 180	20 - 28
Thin slice of sirloin, medium*	1 kg	Wire rack + baking tray	2	Hot air	170 - 180	40 - 55
Thin slice of sirloin, rare*	1 kg	Wire rack + baking tray	2	Hot air	170 - 180	30 - 45
Thick piece of sirloin, medium*	1 kg	Wire rack + baking tray	2	Hot air	170 - 180	45 - 60
Thick piece of sirloin, rare*	1 kg	Wire rack + baking tray	2	Hot air	170 - 180	35 - 50

\* Sear first

### Veal

Food	Amount	Accessories	Level	Operating mode	Temperature in °C	Cooking time in min.
Joint of veal, marbled	1 kg	Wire rack + baking tray	2	CircoSteam®	160 - 170	60 - 70
Joint of veal, lean	1 kg	Wire rack + baking tray	2	CircoSteam®	160 - 170	50 - 60
Veal back*	1 kg	Wire rack + baking tray	2	CircoSteam®	160 - 180	15 - 25
Breast of veal, stuffed	1.5 kg	Wire rack + baking tray	2	CircoSteam®	140 - 160	75 - 120

\* Sear first

### Pork

Food	Amount	Accessories	Level	Operating mode	Temperature in °C	Cooking time in min.
Joint without rind (e.g. neck)	1.5 kg	Wire rack + baking tray	2	CircoSteam®	170 - 180	70 - 80
Joint with rind (crackling)	1.5 kg	Wire rack + baking tray	2	Steam cooking	100	20 - 25
				CircoSteam®	140 - 160	40 - 50
				Hot air	210 - 220	20
Pork fillet*	0.5 kg	Wire rack + baking tray	2	CircoSteam®	160 - 180	20 - 30

\* Sear first

Food	Amount	Accessories	Level	Operating mode	Temperature in °C	Cooking time in min.
Fillet in puff pastry	1 kg	Baking tray	2	CircoSteam®	180 - 200	40 - 60
Smoked pork on the bone	1 kg	Wire rack + baking tray	2	CircoSteam®	120 - 140	60 - 70
Smoked pork ribs	sliced	Baking tray	2	Steam cooking	100	15 - 20
Rolled joint	1.5 kg	Wire rack + baking tray	2	CircoSteam®	170 - 180	70 - 80

\* Sear first

### Miscellaneous

Food	Amount	Accessories	Level	Operating mode	Temperature in °C	Cooking time in min.
Meat loaf	made from 0.5 kg minced meat	Baking tray	2	CircoSteam®	140 - 150	45 - 60
Saddle of venison on the bone*	0.6 - 0.8 kg	Wire rack + baking tray	2	CircoSteam®	150 - 170	15 - 30
Boned leg of lamb	1.5 kg	Wire rack + baking tray	2	CircoSteam®	170 - 180	60 - 80
Saddle of lamb on the bone*	1.5 kg	Wire rack + baking tray	2	CircoSteam®	160 - 170	15 - 25
Rabbit portions	1.5 kg	Wire rack + baking tray	2	CircoSteam®	150 - 160	40 - 60
Wiener sausages	-	Perforated + Baking tray	3 1	Steam cooking	80 - 85	12 - 18
Bavarian veal sausages	-	Perforated + Baking tray	3 1	Steam cooking	80 - 85	15 - 20

\* Sear first

### Roasting tips

Using the roasting set	Using the roasting set will give optimum results and the cooking compartment will stay as clean as possible. You can purchase the roasting set as an accessory from specialist retailers (see section: Accessories)
When is the roast ready?	Use a meat thermometer (available from specialist retailers) or carry out the "spoon test": press down on the roast with a spoon. If it feels firm, it is ready. If the spoon can be pressed in, it needs to be cooked for a little longer.
The roast is too dark and the outside is burnt in places.	Check the shelf height and temperature.
The roast looks good but the juices are burnt.	Next time, choose a smaller roasting dish or add more liquid.
The roast looks good, but the juices are too clear and watery.	Next time, choose a larger roasting dish or add less liquid.

### Fish

Food	Amount	Accessories	Level	Operating mode	Temperature in °C	Cooking time in min.
Sea bream, whole	per 0.3 kg	Perforated + Baking tray	3 1	Steam cooking	80 - 90	15 - 25
Sea bream fillet	per 0.15 kg	Perforated + Baking tray	3 1	Steam cooking	80 - 90	10 - 20
Fish terrine	Bain marie 1.5 l	Wire rack	2	Steam cooking	70 - 80	40 - 80
Trout, whole	per 0.2 kg	Perforated + Baking tray	3 1	Steam cooking	80 - 90	12 - 15
Cod fillet	per 0.15 kg	Perforated + Baking tray	3 1	Steam cooking	80 - 90	10 - 14
Salmon fillet	per 0.15 kg	Perforated + Baking tray	3 1	Steam cooking	100	8 - 10
Mussels	1.5 kg	Baking tray	2	Steam cooking	100	10 - 15
Ocean perch fillet	per 0.15 kg	Perforated + Baking tray	3 1	Steam cooking	80 - 90	10 - 20
Sole rolls, stuffed	-	Perforated + Baking tray	3 1	Steam cooking	80 - 90	10 - 20

## Bakes, soup ingredients, etc.

Food	Accessories	Level	Operating mode	Temperature in °C	Cooking time in min.
Savoury bake made from cooked ingredients	Ovenproof dish + wire rack	2	CircoSteam®	150 - 170	30 - 40
Sweet bake	Ovenproof dish + wire rack	2	CircoSteam®	150 - 170	30 - 45
Lasagne	Baking tray	2	CircoSteam®	160 - 170	35 - 45
Soufflé	Mould + wire rack	2	CircoSteam®	180 - 200	15 - 25
Royale	Solid	2	Steam cooking	90	15 - 20
Semolina dumplings	Perforated + Baking tray	3 1	Steam cooking	90 - 95	7 - 10
Hard-boiled eggs (Size M, max. 1.8 kg)	Perforated + Baking tray	3 1	Steam cooking	100	10 - 12
Soft-boiled eggs (Size M, max. 1 kg)	Perforated + Baking tray	3 1	Steam cooking	100	6 - 8

## Dessert, compote

### Compote:

Weigh the fruit and add approximately  $\frac{1}{3}$  the amount of water, then add sugar and spices to taste.

### Rice pudding

Weigh the rice and add 2.5 times the amount of milk. Ensure the level of rice and milk in the accessory is no higher than 2.5 cm. Stir after cooking. The remaining milk is quickly absorbed.

### Yoghurt

Heat the milk to 90 °C on the hob. Then leave to cool to 40 °C. If you are using UHT milk, you do not need to heat it.

Stir in one to two teaspoons of natural yoghurt per 100 ml milk, or the corresponding amount of yoghurt culture into the milk. Pour the mixture into clean jars and seal them.

After preparation, leave the glasses to cool in the refrigerator.

Food	Accessories	Operating mode	Temperature in °C	Cooking time in min.
Yeast dumplings	Baking tray	Steam cooking	100	20 - 25
Crème caramel	Mould + wire rack	Steam cooking	90 - 95	15 - 20
Sweet bake (e.g. semolina pudding)	Ovenproof dish + wire rack	CircoSteam®	160 - 170	50 - 60
Rice pudding*	Baking tray	Steam cooking	100	25 - 35
Yoghurt*	Portion-sized glasses + wire rack	Steam cooking	40	300 - 360
Apple compote	Baking tray	Steam cooking	100	10 - 15
Pear compote	Baking tray	Steam cooking	100	10 - 15
Cherry compote	Baking tray	Steam cooking	100	10 - 15
Rhubarb compote	Baking tray	Steam cooking	100	10 - 15
Plum compote	Baking tray	Steam cooking	100	15 - 20

\* You can also use the appropriate programme (see section: Automatic programmes)

## Cakes and pastries

It is best to use dark-coloured metal baking tins.

The temperature and cooking time depend on the quantity and composition of the dough. That is why ranges of temperatures are given in the tables.

First set the lower temperature. This will brown the dish more evenly. A higher temperature can be selected next time, if required.

Do not overpack the wire rack or baking tray with food.

### Cakes in tins

Food	Accessories	Level	Operating mode	Temperature in °C	Cooking time in min.
Sponge cake	Ring/loaf tin	2	Hot air	150 - 160	60 - 70
Sponge flan base	Flan tin	2	Hot air	150 - 160	30 - 45
Delicate fruit flan, sponge	Springform cake tin	2	Hot air	150 - 160	45 - 55
Sponge base (2 eggs)	Flan tin	2	Hot air	180 - 190	12 - 16
Fatless sponge cake (6 eggs)	Springform cake tin	2	Hot air	150 - 160	25 - 35
Shortcrust pastry base with crust	Springform cake tin	2	Hot air	150 - 160	40 - 50
Swiss flan	Springform cake tin	2	Hot air	180 - 190	35 - 60

Food	Accessories	Level	Operating mode	Temperature in °C	Cooking time in min.
Ring cake	Ring cake tin	2	CircoSteam®	150 - 160	35 - 45
Savoury cakes (e.g. quiche)	Quiche dish	2	Hot air	180 - 190	35 - 60
Apple tart	Flan-base cake tin	2	Hot air	170 - 190	35 - 50

### Cakes on trays

Food	Accessories	Level	Operating mode	Temperature in °C	Cooking time in min.
Yeast cake with dry topping	Baking tray	2	CircoSteam®	150 - 160	35 - 45
Yeast cake with moist topping (fruit)	Baking tray	2	Hot air	150 - 160	35 - 45
Swiss roll	Baking tray	2	Hot air	180 - 200	10 - 15
Plaited loaf (500 g flour)	Baking tray + greaseproof paper	2	CircoSteam®	150 - 160	25 - 35
Strudel, sweet	Baking tray	2	CircoSteam®	160 - 180	40 - 60
Onion cake	Baking tray	2	CircoSteam®	170 - 180	30 - 40

### Bread, bread rolls

Food	Accessories	Level	Operating mode	Temperature in °C	Cooking time in min.
White bread (750 g flour)	Baking tray + greaseproof paper	2	CircoSteam®	200 - 210	15 - 20
			Hot air	160 - 170	20 - 25
Sourdough bread (750 g flour)	Baking tray + greaseproof paper	2	CircoSteam®	200 - 220	15 - 25
			Hot air	150 - 160	40 - 60
Multigrain bread (750 g flour)	Baking tray + greaseproof paper	2	CircoSteam®	200 - 220	15 - 20
			Hot air	160 - 170	25 - 40
Wholemeal bread (750 g flour)	Baking tray + greaseproof paper	2	CircoSteam®	200 - 220	20 - 30
			Hot air	140 - 150	40 - 60
Rye bread (750 g flour)	Baking tray + greaseproof paper	2	CircoSteam®	200 - 220	20 - 30
			Hot air	150 - 160	50 - 60
Bread rolls (70 g each, unbaked)	Baking tray + greaseproof paper	2	CircoSteam®	190 - 200	25 - 30
Bread rolls made with sweet yeast dough (70 g each, unbaked)	Baking tray + greaseproof paper	2	CircoSteam®	170 - 180	20 - 30

### Small baked items

Food	Accessories	Level	Operating mode	Temperature in °C	Cooking time in min.
Meringue	Baking tray	2	Hot air	80 - 90	120 - 180
Macaroons	Baking tray	2	Hot air	140 - 160	15 - 25
Puff pastry	Baking tray	2	CircoSteam®	170 - 190	10 - 20
Muffins	Bun tray	2	Hot air	170 - 180	20 - 30
Choux pastry	Baking tray	2	Hot air	170 - 190	27 - 35
Biscuits	Baking tray	2	Hot air	150 - 160	12 - 17
Leavened cake	Baking tray	2	Hot air	150 - 160	15 - 20

### Baking tips

You want to bake according to your own recipe Use similar items in the baking tables as a guide

How to tell whether sponge cake is baked through Approx. 10 minutes before the end of the baking time stated in the recipe, insert a cocktail stick into the cake at its deepest point. If the cocktail stick comes out clean, the cake is ready.

The cake collapses Next time, use less liquid or set the baking temperature 10 °C lower. Note the stirring times indicated in the recipe.

The cake has risen in the middle but is lower around the edge Do not grease the edge of the springform cake tin. After baking, carefully loosen the cake using a knife

Cakes baked in a tray or tin are over-browned at the back	Place the baking tray in the middle of the accessories, not directly against the rear wall
The cake is too dry	Make tiny holes in the finished cake using a cocktail stick. Then drizzle fruit juice or an alcoholic drink over it. Next time, set the temperature 10 °C higher and shorten the baking times or use the CircoSteam® operating mode
The bread or cake looks good but it is soggy inside (overmoist with wet streaks)	Next time, use less liquid. Bake at a lower temperature for a little longer. For cakes with a moist topping, bake the base first. Cover the base with almonds or bread crumbs first and then apply the topping. Observe the baking time in the recipe
The cake or pastry is unevenly browned	Next time, set the temperature a little lower

## Reheating food

Using Reheat, dishes can be gently reheated. They taste and look like they have been freshly prepared. Even baked items from the day before can be recrisped.

Food	Accessories	Level	Operating mode	Temperature in °C	Cooking time in min.
Meals on plates	Wire rack	2	Reheat	120	12 - 18
Vegetables	Baking tray	3	Reheat	100	12 - 15
Pasta, potatoes, rice	Baking tray	3	Reheat	100	5 - 10
Bread rolls*	Wire rack	2	CircoSteam®	170 - 180	6 - 8
Baguette*	Wire rack	2	CircoSteam®	170 - 180	5 - 10
Bread*	Wire rack	2	CircoSteam®	170 - 180	8 - 12
Pizza	Wire rack + baking tray	3	Reheat	170 - 180	12 - 15

\* Preheat for 5 minutes

## Defrosting

When freezing, lay the food as flat as possible and in portion-sized pieces at -18 °C. Do not freeze excessively large quantities. Once defrosted, food will not keep for as long and spoils more quickly than fresh food.

Leave the food to defrost in the freezer bag, on a plate or on the perforated cooking container. Always insert the baking tray underneath. The food is then not left lying in the defrost water and the cooking compartment remains clean.

Use the Steam cooking operating mode.

If necessary, the food can occasionally be split apart or pieces which have already defrosted can be removed from the appliance.

After defrosting, allow the food to stand for a further 5 - 15 minutes to come up to room temperature.

### Health risk!

When defrosting food from animal sources, you must remove the liquid that escapes during defrosting. It must never come into contact with other food. Bacteria could be transferred. After defrosting, operate the combination steam oven for 15 minutes using Hot air at 180 °C.

#### Defrost meat

Allow pieces of meat which are to be breadcrumbed to defrost to the point where seasoning and breadcrumbs adhere to the meat.

#### Defrosting poultry

Remove from packaging before defrosting. You must tip the defrost liquid away.

Food	Amount	Accessories	Level	Temperature in °C	Cooking time in min.
Chicken	1 kg	perforated + baking tray	3 1	45 - 50	60 - 70
Chicken drumsticks	0.4 kg	perforated + baking tray	3 1	45 - 50	30 - 35
Vegetables frozen in blocks (e.g. spinach)	0.4 kg	perforated + baking tray	3 1	45 - 50	20 - 30
Berries	0.3 kg	perforated + baking tray	3 1	45 - 50	5 - 8
Fish fillet	0.4 kg	perforated + baking tray	3 1	45 - 50	15 - 20
Whole fish	1 kg	perforated + baking tray	3 1	45 - 50	40 - 50
Goulash	-	perforated + baking tray	3 1	45 - 50	40 - 50
Joint of beef	-	perforated + baking tray	3 1	45 - 50	70 - 80

## Proving dough

With Steam cooking, dough will prove considerably more quickly than at room temperature.

You can select any shelf position you wish for the wire rack or you can place the wire rack carefully on the cooking

compartment floor.

Caution: Do not scratch the cooking compartment floor.

Stand the dough bowl on the wire rack. Do not cover the dough.

Food	Amount	Accessories	Temperature in °C	Cooking time in min.
Yeast dough	1 kg	Bowl + wire rack	35	20 - 30
Sourdough	1 kg	Bowl + wire rack	35	20 - 30

## Juicing

Before juicing, place the berries in a bowl and sprinkle with sugar. Leave to stand for at least one hour to draw out the juice.

Add the berries to the perforated cooking container and insert at level 3. Slide the baking tray into level 1 to catch the juice.

Finally, place the berries in a cloth and squeeze out the rest of the juice.

Food	Accessories	Level	Operating mode	Temperature in °C	Cooking time in min.
Raspberries	Perforated cooking container + baking tray	3 1	Steam cooking	100	30 - 45
Redcurrants	Perforated cooking container + baking tray	3 1	Steam cooking	100	40 - 50

## Preserve

Preserve food which is as fresh as possible. When foods are stored for a relatively long period, their vitamin content is reduced and they cook more readily.

Only use fruit and vegetables which are in perfect condition.

The following foods cannot be preserved with your appliance: Contents of tins, meat, fish or pastry dough.

Check preserving jars, rubber rings, clips and springs.

Clean rubber rings and jars thoroughly with hot water. The "Sterilise bottles" programme is also suitable for cleaning glasses.

Place the jars in the perforated cooking container. They must not be in contact with each other.

After the specified cooking time, open the appliance door.

Do not remove the preserving jars from the appliance until they have completely cooled down.

Food	Accessories	Level	Operating mode	Temperature in °C	Cooking time in min.
Vegetables	1-litre preserving jars	2	Steam cooking	100	30 - 120
Stone fruits	1-litre preserving jars	2	Steam cooking	100	25 - 30
Pip fruits	1-litre preserving jars	2	Steam cooking	100	25 - 30

## Frozen products

Observe the instructions on the packaging.

The cooking times indicated apply to dishes placed in a cold cooking compartment.

Food	Accessories	Level	Operating mode	Temperature in °C	Cooking time in min.
Chips	Baking tray + greaseproof paper	2	Hot air	170 - 190	25 - 35
Croquettes	Baking tray + greaseproof paper	2	Hot air	180 - 200	18 - 22
Rösti	Baking tray + greaseproof paper	2	Hot air	180 - 200	25 - 30
Pasta, fresh, refrigerated*	Baking tray	2	Steam cooking	100	5 - 10
Lasagne, frozen	Baking tray + wire rack	2	CircoSteam®	190 - 210	35 - 55
Pizza, thin base	Baking tray + wire rack	2	Hot air	180 - 200	15 - 23
Pizza, deep pan	Baking tray + wire rack	2	Hot air	180 - 200	18 - 25
Pizza baguette	Baking tray + wire rack	2	Hot air	180 - 200	18 - 22
Pizza, chilled	Baking tray	2	Hot air	170 - 180	12 - 17

\* Add a little liquid



<b>Food</b>	<b>Accessories</b>	<b>Level</b>	<b>Operating mode</b>	<b>Temperature in °C</b>	<b>Cooking time in min.</b>
Herb butter baguette, refrigerated	Baking tray	2	Hot air	180 - 200	15 - 20
Bread rolls, baguette, frozen	Baking tray + wire rack	2	Hot air	180 - 200	18 - 22
Pretzels, frozen	Baking tray + greaseproof paper	2	Hot air	180 - 200	18 - 22
Croissant, frozen	Baking tray + greaseproof paper	2	CircoSteam®	180 - 200	20 - 25
Part-cooked rolls or baguette, pre-baked	Baking tray + greaseproof paper	2	Hot air	150 - 170	12 - 15
Strudel, frozen	Baking tray + greaseproof paper	2	CircoSteam®	160 - 180	45 - 60
Fish fingers	Baking tray + greaseproof paper	2	Hot air	195 - 205	20 - 24
Trout	Perforated + Baking tray	3 1	Steam cooking	80 - 100	20 - 25
Frozen fish fillet	Baking tray + wire rack	2	CircoSteam®	180 - 200	35 - 50
Salmon fillet	Perforated cooking container + Baking tray	3 1	Steam cooking	80 - 100	20 - 25
Squid rings	Baking tray + greaseproof paper	2	Hot air	190 - 210	25 - 30
Broccoli	Perforated cooking container + Baking tray	3 1	Steam cooking	100	4 - 6
Cauliflower	Perforated cooking container + Baking tray	3 1	Steam cooking	100	5 - 8
Beans	Perforated cooking container + Baking tray	3 1	Steam cooking	100	4 - 6
Peas	Perforated cooking container + Baking tray	3 1	Steam cooking	100	4 - 6
Carrots	Perforated cooking container + Baking tray	3 1	Steam cooking	100	3 - 5
Mixed vegetables	Perforated cooking container + Baking tray	3 1	Steam cooking	100	4 - 8
Brussels sprouts	Perforated cooking container + Baking tray	3 1	Steam cooking	100	5 - 10

\* Add a little liquid

# Test dishes

These tables have been produced for test institutes to facilitate the inspection and testing of the various appliances.

## Baking

Test dishes tested in accordance with standards EN 50304/ EN 60350 (2009) and IEC 60350.

**Note:** For baking, use the lower of the temperatures indicated first.

The values in the table apply to dishes placed in a cold cooking compartment.

Food	Accessories	Level	Operating mode	Temperature in °C	Cooking time in min.
Piped cookies	Baking tray	2	Hot air	160 - 170	17 - 20
Small cakes	Baking tray	2	Hot air	160 - 170	25 - 33
Hot water sponge cake	26 cm springform cake tin	2	Hot air	150 - 160	35 - 40
Double crust apple pie	20 cm springform cake tin	2	Hot air	160 - 170	60 - 70

## Steaming

Test dishes tested in accordance with standard EN 60350-1.

Food	Accessories	Level	Operating mode	Temperature in °C	Cooking time in min.
Broccoli (Steam distribution)	Perforated + baking tray	3 1	Steam cooking	100	*
Broccoli (Steam supply)	Perforated + baking tray	3 1	Steam cooking	100	*
Peas** (Maximum load)	Perforated + baking tray	3 1	Steam cooking	100	***

\* The cooking time for "al dente" must be established beforehand.

\*\* Spread out 2.0 kg of peas evenly in the container.

\*\*\* The end of the cooking time has been reached when the peas at the coldest point have reached a temperature of 85 °C.



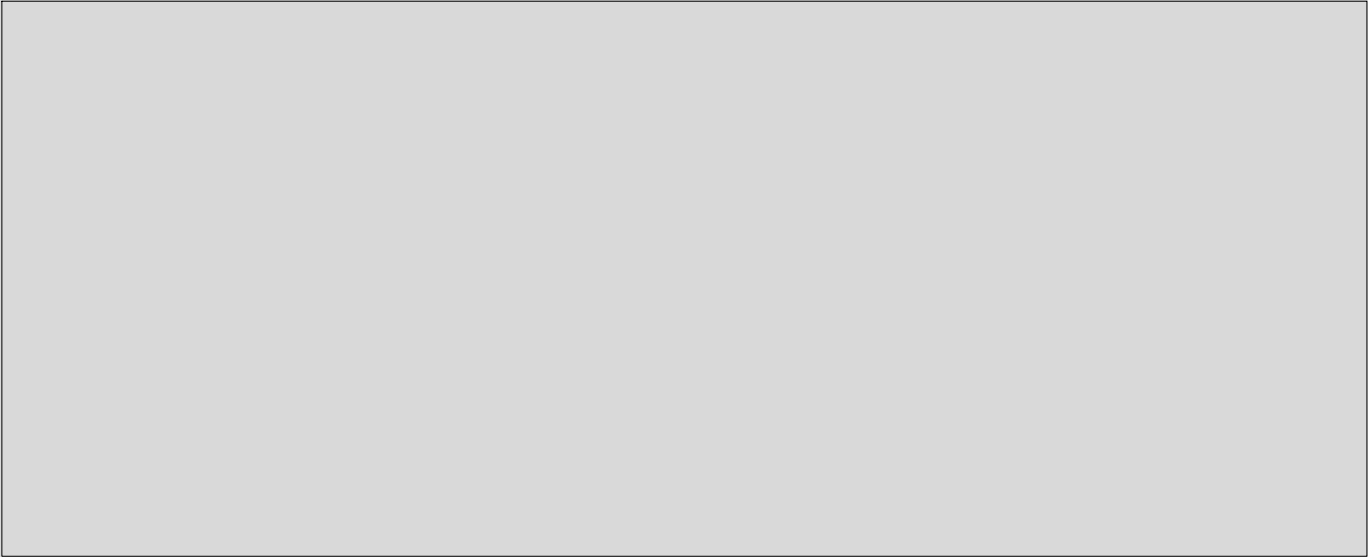

Constructa Neff  
Vertriebs-GmbH  
Carl-Wery-Straße 34  
D-81739 München



9000762279

930208