

Vacuuming drawer











Instruction manual

N17XH10.0B





# Table of contents

	<b>Intended use</b> . . . . .	<b>4</b>
	<b>Important safety information</b> . . . . .	<b>4</b>
	<b>Causes of damage</b> . . . . .	<b>5</b>
	<b>Environmental protection</b> . . . . .	<b>5</b>
	Environmentally-friendly disposal . . . . .	5
	<b>Getting to know your appliance</b> . . . . .	<b>6</b>
	How does a vacuuming drawer work? . . . . .	6
	Structure of the vacuuming drawer . . . . .	6
	Control panel . . . . .	6
	Opening and closing . . . . .	7
	Accessory . . . . .	7
	<b>Operating the appliance</b> . . . . .	<b>7</b>
	Switch the appliance on and off. . . . .	7
	Vacuumping in the bag . . . . .	7
	Vacuumping in the container . . . . .	9
	Carrying out the drying program for vacuum pump . . . . .	9
	<b>Settings table and tips</b> . . . . .	<b>10</b>
	Vacuum for sous-vide cooking . . . . .	10
	Fast marinating and flavouring . . . . .	10
	Storage and transport . . . . .	10
	Recommended settings . . . . .	11
	<b>Cleaning</b> . . . . .	<b>12</b>
	<b>Trouble shooting</b> . . . . .	<b>13</b>
	<b>Customer service</b> . . . . .	<b>15</b>
	E number and FD number . . . . .	15
	Technical specifications . . . . .	15

---

Additional information on products, accessories, replacement parts and services can be found at **www.neff-international.com** and in the online shop **www.neff-eshop.com**

## Intended use

Read these instructions carefully. Only then will you be able to operate your appliance safely and correctly. Retain the instruction manual and installation instructions for future use or for subsequent owners.

Check the appliance for damage after unpacking it. Do not connect the appliance if it has been damaged in transport.

This appliance is intended for domestic use and the household environment only. Only use the appliance to vacuum food in suitable vacuuming bags and vacuuming containers, and to heat-seal film.

Only operate this appliance in enclosed rooms.

This appliance may be used by children over the age of 8 years old and by persons with reduced physical, sensory or mental capabilities or by persons with a lack of experience or knowledge if they are supervised or are instructed by a person responsible for their safety how to use the appliance safely and have understood the associated hazards.

Children must not play with, on, or around the appliance. Children must not clean the appliance or carry out general maintenance unless they are at least 15 years old and are being supervised.

Keep children below the age of 8 years old at a safe distance from the appliance and power cable.

This appliance is intended for use up to a maximum height of 4000 metres above sea level.

## Important safety information

### **Warning** **Risk of burns!**

The sealing bar in the vacuuming chamber becomes extremely hot if the appliance is used frequently and there are long heat-sealing times. Never touch the hot sealing bar. Keep children away from the appliance.

### **Warning** **Risk of electric shock!**

- Do not use any high-pressure cleaners or steam cleaners, which can result in an electric shock.
- A defective appliance may cause electric shock. Never switch on a defective appliance. Unplug the appliance from the mains or switch off the circuit breaker in the fuse box. Contact the after-sales service.

- Incorrect repairs are dangerous. Repairs may only be carried out by one of our trained after-sales engineers. If the appliance is faulty, unplug the mains plug or switch off the fuse in the fuse box. Contact the after-sales service.

### **Warning** **Risk of fire!**

The sealing bar in the vacuuming chamber becomes extremely hot. Combustible vapours may ignite. Do not vacuum any combustible liquids in the vacuuming bag. Do not store any combustible materials and objects inside the appliance.

### **Warning** **Risk of injury!**

- The smallest cracks in the glass lid may result in it imploding when the vacuum is attached. Unplug the appliance from the mains or switch off the circuit breaker in the fuse box. Call the after-sales service.
- During the vacuuming process, the vacuuming chamber and the glass lid deform. Screw-top jars, other hard containers, and indeformable food that are vacuumed in the compartment when the lid is closed must not come into contact with this lid. Otherwise, the protective layer on the glass will be damaged and the glass lid may break. Hard containers and indeformable food must not protrude over a maximum height of 80 mm.
- Any misuse of the vacuuming drawer may lead to injury. Do not insert any hoses that are connected to the appliance into any body cavities. Do not vacuum any living animals.

## Causes of damage

### Caution!

- Check the appliance for damage before each use. Pay particular attention to the intactness of the glass lid. Do not operate the appliance if the glass lid is damaged. Call the after-sales service.
- Slowly open and close the glass lid.
- Do not place any objects on the glass lid. Do not use the appliance as a work surface or storage space. Ensure that no objects can fall onto the glass lid. To use it, pull the drawer out fully until it reaches a stop. Completely close the drawer if you are not using it.
- Before closing the glass lid, ensure that there is no debris in the vacuuming chamber.
- Ensure that the seals are not damaged by pointed or sharp objects.
- Check that the seal on the glass lid is positioned correctly. Ensure that the seal's contact surface is clean and free from debris. Otherwise, this may impair the functionality of the appliance. Do not operate the appliance if the seal is defective. If you do so, this may damage the appliance. Call the after-sales service.
- Observe the cleaning instructions.
- In the event of a power failure, the vacuum remains in the vacuuming chamber during the vacuuming process. Never attempt to use a tool to open the glass lid. Wait until the power supply has been re-established and restart the vacuuming process.
- Do not vacuum food in its original packaging after you have opened it. Only use bags that are suitable for vacuuming food.
- In the vacuum, liquids start to boil at low temperatures. This produces vapour and may cause the appliance to malfunction.
- Ensure that the food to be vacuumed is at the lowest possible initial temperature – within the range of 1 – 8 °C is best.
- Never vacuum liquids in the vacuuming bag at the maximum vacuuming level.
- Recommendation: Vacuum liquids in the vacuuming bag at vacuuming level 2.
- Carefully monitor the vacuuming process. It is normal for some bubbles to form when vacuuming liquids. Heat-seal the bag in good time as soon as the bubble formation visibly increases.
- Tip: You can also vacuum liquids in fixed, commercially available vacuuming containers. Use vacuuming level 3 for this. When vacuuming, do not use any plastic bottles or other vessels that contract during external vacuuming.

## Environmental protection

### Environmentally-friendly disposal

Dispose of packaging in an environmentally-friendly manner.



This appliance is labelled in accordance with European Directive 2012/19/EU concerning used electrical and electronic appliances (waste electrical and electronic equipment - WEEE). The guideline determines the framework for the return and recycling of used appliances as applicable throughout the EU.

# Getting to know your appliance

In the vacuuming drawer, you can vacuum food in suitable bags and containers. This chapter provides you with information about the assembly and the basic functions of your appliance.

## How does a vacuuming drawer work?

During the vacuuming process, air is pumped out of the vacuuming chamber and the bag. This produces a high vacuum in the chamber. The higher the vacuuming level, the less air remains in the chamber and the bag, and the higher the pressure difference to the environment.

If the selected vacuuming level has been reached, the sealing bar is pressed against the silicone column on the glass lid. During this, the bag is heat-sealed. After a short cooling time, air flows back into the chamber, creating a loud noise. During this process, the bag suddenly contracts and encloses the food. The drawer's glass lid then opens.

Different degrees of vacuum can be created with vacuuming levels 1 to 3. The degrees that are reached here vary depending on the use case: When vacuuming in the container, the degrees of vacuum are lower and therefore better suited for the particular food. When the external vacuuming adaptor is attached, the vacuuming drawer automatically detects which mode has just been activated.

Vacuuming levels	1	2	3
Vacuuming in the bag	80%	95%	99%
Vacuuming containers and bottles	50%	75%	90%

## Structure of the vacuuming drawer

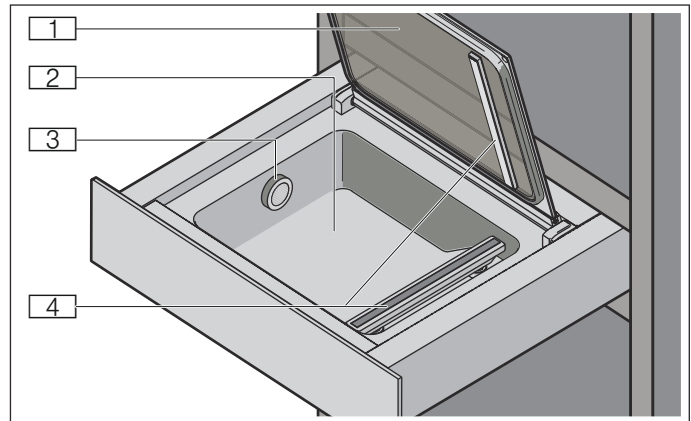

- 1 Safety glass cover
- 2 Stainless steel vacuuming chamber
- 3 Air outlet
- 4 Sealing bar

## Control panel

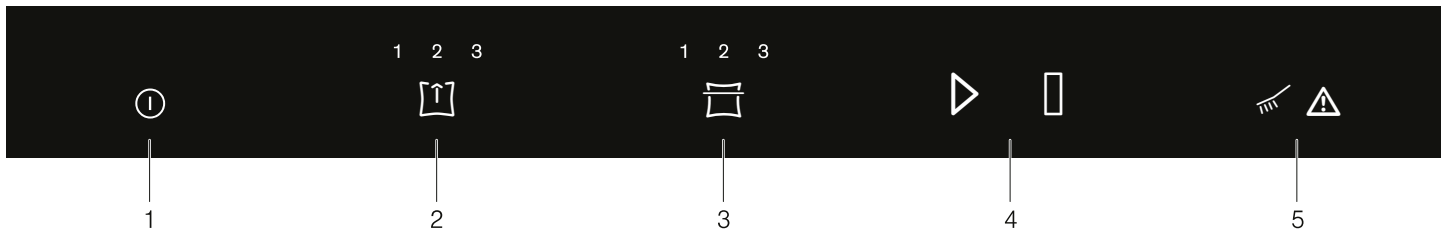



Symbol	Explanation
1	Switch on/off Switch the appliance on and off
2	Vacuum-sealing level Select the vacuum-sealing level
3	Heat-sealing time Select a heat-sealing time Heat-seal the vacuum-sealing bag early
4	Start Start the vacuum-sealing process
	Stop Cancel the vacuum-sealing process
5	Dry Dry the pump
	Note Refer to the fault table

## Opening and closing

Press on the middle of the drawer to open or close it. The drawer will spring out gently when you open it. You can then easily pull it out.

## Accessory

The following accessories are included with the vacuum-sealing drawer:

	<p><b>External vacuum-sealing adapter</b></p> <p>The adapter is attached to the air outlet on the vacuum-sealing drawer in order to vacuum-seal vacuum-sealing containers.</p>
	<p><b>Vacuum-sealing hose</b></p> <p>The vacuum-sealing hose connects the external vacuum-sealing adapter to the vacuum-sealing container.</p>
	<p><b>Vacuum-sealing bags</b></p> <p>180 x 280 mm (50 pcs) 240 x 350 mm (50 pcs)</p>

## Optional accessories

You can order optional accessories from our after-sales service or from your specialist retailer:

Accessories	Specialist retailer order number	After-sales service order number
Vacuum-sealing bag 180 x 280 mm (x 100)	Z13CX62X0	17000224
Vacuum-sealing bag 240 x 350 mm (x 100)	Z13CX64X0	17000225

## Operating the appliance

### Switch the appliance on and off

Touch the  symbol to switch the appliance on or off. If you do not make any changes, the appliance automatically switches off after 10 minutes.

### Vacuuming in the bag

Vacuum the food in a suitable vacuuming bag in order to preserve the food for longer, to marinate it or to prepare it for sous-vide cooking.

#### Suitable vacuuming bag

Use the original vacuuming bags that are enclosed with the appliance or can be ordered as accessories. These bags are suitable for a temperature range of -40 °C – 100 °C. This means that they can be used for storing food at low temperatures and also for cooking the vacuum-sealed food that is contained in the bags. The optimum heat-sealing time for this bag is level 2. The bags are suitable for use in the microwave. Pierce the bag before you heat it up in the microwave.

Only use bags that are suitable for vacuuming food. Commercially available products are different when it comes to the quality of the food, temperature resistance, material and surface. Ensure that the bag is used only for the purpose for which it is intended.

The heat-sealing time for the vacuuming bag always depends on the material from which it is made. In most cases, heat-sealing level 1 is sufficient for heat-sealing thin bags. Vacuuming bags that are made from a thicker material require a longer heat-sealing time at heat-sealing level 2 or higher.

The length of the heat-sealing column limits the size of the vacuuming bag that can be used. You should therefore only use bags with a maximum width of 240 mm.

#### Filling the bag

Where possible, position the items of food in the vacuum-sealing bag next to each other and not on top of each other.

To ensure that the sealing seam is perfect, it is important that the edge of the bag is clean and dry. To ensure that the seam is perfect during the heat-sealing process, it is important that there is no food residue around the seam on the edge of the bag. Before you fill the bag, you should therefore fold over its edge by approx. 3 cm. Unfold the edge again once the bag has been filled.

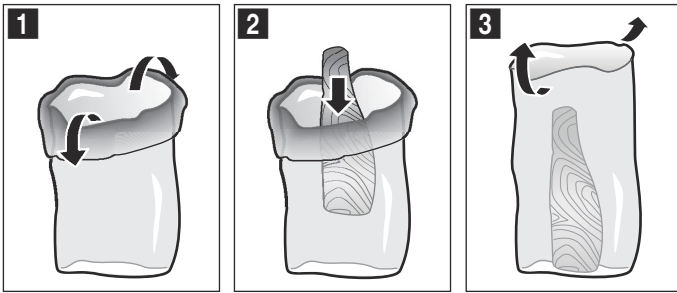

To ensure that you can keep track of your bags and the food that is vacuumed within them, we recommend that you make a note on the bag of the date of the vacuuming along with the contents.

**Proceed as follows:**

1. Open the glass lid.
2. Place the vacuum-sealing bag in the compartment.

**Notes**

- Make sure that the food is at the lowest possible initial temperature – within the range of 1 – 8 °C is best.
- Make sure that the air outlet is not covered so that the pump can extract the air from the compartment.
- Make sure that the centre of the bag and the ends of the bag are lying flat on top of the heat-sealing column. This will ensure that the heat-sealing seam is perfectly closed.
- Make sure that the open end of the bag is protruding over the heat-sealing column by approx. 3 cm but that it is not touching the lid seal.

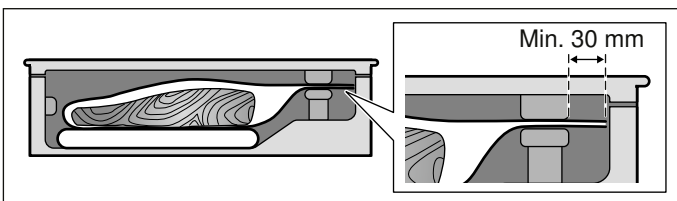

**Note:** Elevate the bag if necessary using an item such as a chopping board to prevent the bag from sliding down.

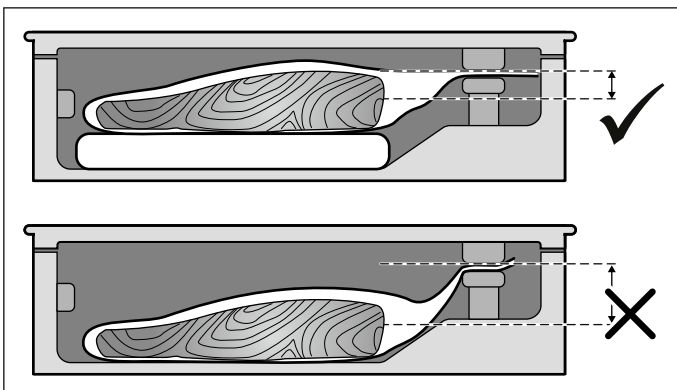

3. Touch the [1] symbol to select a vacuum-sealing level.
4. Touch the [2] symbol to select a heat-sealing time.
5. Tightly close the glass lid and hold it there.

6. Touch the ▷ symbol to start the vacuum-sealing process.

The vacuum-sealing process will now start. The vacuum-sealing level indicators will flash red one after the other until the value you selected has been reached.

The heat-sealing process will now start. The heat-sealing level indicators will flash red one after the other until the value you selected has been reached.

At the end of the process, the chamber is ventilated and an acoustic signal sounds. You can now open the glass lid and remove the heat-sealed vacuum-sealing bag from the chamber.

**Warning**

**Risk of burns!**

The sealing bar in the vacuuming chamber becomes extremely hot if the appliance is used frequently and there are long heat-sealing times. Never touch the hot sealing bar. Keep children away from the appliance.

**Notes**

- At the highest vacuuming level, the process may last up to 2 minutes. After this time, the bag is heat-sealed and the vacuuming level that is reached lights up.
- After vacuuming, check the heat-sealing seam on the bag. Carefully try to pull the seam apart. If it comes apart, select a higher heat-sealing level the next time. If the seam is deformed, it has become too hot. Select a lower heat-sealing level the next time or leave the appliance to cool.
- If you vacuum food in bags several times in succession, the heat-sealing column becomes increasingly hotter. This may impair the quality of the heat-sealing seam. After several vacuuming processes, you should therefore select a lower heat-sealing time or leave the appliance to cool for approx. 2 minutes between the processes.

**Heat-sealing in good time**

Use this function if you only want to pack your delicate food in a bag so that it is air-tight, without the contents sitting too tightly against the bag.

When air is being extracted from the bag, touch the [3] symbol to end the process and heat-seal the bag early.

The appliance displays the vacuuming level until it is reached.

At the end of the process, the chamber is ventilated and an acoustic signal sounds. You can now open the glass lid and remove the heat-sealed vacuuming bag from the chamber.

**Note:** To heat-seal the bag, the vacuum-sealing drawer requires a specific degree of vacuum. If you touch the [3] symbol first, the vacuum-sealing drawer pumps air out of the chamber until this degree has been reached. The bag is then heat-sealed.



### Cancelling the vacuuming process

When air is being extracted from the bag, touch the  symbol to cancel the process early.

The appliance displays the vacuuming level until it is reached.

The bag is not heat-sealed. The lid opens slightly and the chamber is ventilated. An acoustic signal sounds. You can now remove the vacuuming bag from the chamber.

### Vacuuming in the container

Vacuum the food in a suitable vacuuming container in order to preserve the food for longer.

#### Suitable vacuuming containers



Only use containers that are suitable for vacuuming food. Commercially available products are different when it comes to the quality of the food and the material.

The vacuum hose that is enclosed with this appliance has an inner diameter of 3 mm. To ensure that the hose fits, you may require an adaptor for your container. In many cases, these adaptors are already included with the vacuuming containers.

#### Proceed as follows:

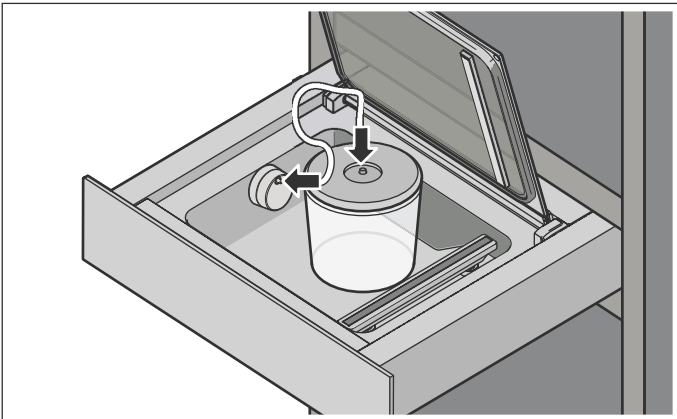
1. Open the glass lid.



2. Plug the vacuuming adaptor into the air outlet.
3. Secure the hose to the vacuuming adaptor and the vacuuming container.
4. Touch the  symbol to select a vacuum-sealing level.
5. Touch the  symbol to start the vacuum-sealing process.

The vacuum-sealing process will now start. The vacuum-sealing level indicators will flash red one after the other until the value you selected has been reached.

The vacuuming levels stop pulsating as soon as the target value has been reached. The vacuuming level that has been reached lights up and an acoustic signal sounds. You can now detach the hose from the container and the external vacuuming adaptor.

**Note:** If larger bubbles form, cancel the vacuuming process.

### Cancelling the vacuuming process

When air is being extracted from the bag, touch the  symbol to cancel the process early.

The appliance displays the vacuuming level until it is reached.

You can now detach the hose from the container and the external vacuuming adaptor.

### Carrying out the drying program for vacuum pump

When vacuuming food, the smallest volume of water gets into the vacuum pump system. This effect is exacerbated when you are vacuuming liquids or extremely moist food. For this reason, the appliance comes with a drying function, which further removes any liquid that gathers in the pump.

If the  symbol is lit white, it is recommended that you run a drying cycle. However, at this point, you can continue to use the appliance as normal if you wish.



If the  symbol is lit red, you must run a drying cycle.

#### Proceed as follows:

1. Tightly close the glass lid and hold it there.
2. Touch the  symbol.

Drying will now start. It will take between 5 and 20 minutes. The  symbol will flash red while drying is in progress. You can close the vacuum-sealing drawer while drying is in progress.

At the end of the program, the chamber is ventilated and an acoustic signal sounds. You can now open the glass lid.

**Note:** It may be the case that a single drying cycle is not sufficient. If, after one drying cycle, the  and  symbols are lit red, there is still moisture in the pump system. Wait until the  symbol goes out and start another drying cycle.

## Settings table and tips

### Vacuum for sous-vide cooking

You can use your vacuuming drawer to prepare food for sous-vide cooking. Sous-vide cooking is a method of cooking "under a vacuum" at low temperatures between 50-95 °C and in 100% steam or in a bain marie.

The vacuuming drawer is used to heat-seal the food in a special air-tight, heat-resistant cooking bag.

#### Warning

##### Health risk!

Sous-vide cooking is a method of cooking at low temperatures. As a result, it is important that you always follow the application and hygiene instructions below:

- Only use high-quality, perfectly fresh food.
- Wash and disinfect your hands. Use disposable gloves or cooking/grill tongs.
- Take extra care when preparing critical food, such as poultry, eggs and fish.
- Always thoroughly rinse and/or peel fruit and vegetables.
- Always keep work surfaces and chopping boards clean. Use different chopping boards for different types of food.
- Maintain the cold chain. Make sure that you only interrupt it briefly to prepare the food, and then return the food in its vacuum-sealed bag to the refrigerator for storage before you cook it.
- Food is suitable for immediate consumption only. Once the food is cooked, consume it immediately. Do not store it after cooking – not even in the refrigerator. It is not suitable for reheating.

#### Vacuuming bags

Use the enclosed vacuuming bags for sous-vide cooking. You can reorder the vacuuming bags.

Do not cook the food in the bag you bought it in (e.g. portions of fish). These bags are not suitable for sous-vide cooking.

Where possible, position the items of food in the bag next to each other and not on top of each other.

#### Vacuuming

Where possible, use the highest vacuuming level to vacuum-seal the food. This is the only way to achieve even heat transfer and therefore a perfect cooking result.

Before cooking the food, check whether the vacuum in the bag is intact. Make sure that:

- There is no/hardly any air in the vacuuming bag.
- The heat-sealing seam is perfectly sealed.
- There are no holes in the vacuuming bag – do not use the core temperature probe.
- Pieces of meat or fish that have been vacuumed together are not pressed directly against one another.
- As far as possible, avoid piling up vegetables and desserts when vacuuming them.

If in doubt, place the food into a new bag and vacuum it again.

Food should be vacuumed at most one day before it is cooked. This is the only way to prevent the escape of gases from the food (e.g. from vegetables) which inhibit the transfer of heat, or to prevent the texture of the food from changing, and thus altering how it cooks.

### Fast marinating and flavouring

You can use your vacuuming bag to quickly add flavour to or marinate food such as meat, fruit and vegetables. Marinating your food in the traditional way usually takes a long time and is not particularly intensive. When you vacuum in a bag, the food's cell pores open and the marinade that is added can be absorbed quickly. This produces a more intensive taste in a much shorter time.

### Storage and transport

Extend the storage time for food. Due to the low-oxygen environment in the vacuum, freshly vacuumed food remains edible for longer when it is stored correctly. The freezer burn is lower when the food has been frozen and vacuumed.

Re-seal food in glass containers (such as jams and sauces). The vacuuming significantly increases the storage time.

#### Notes

- You must ensure that the glass containers that are used are no taller than 80 mm. Taller containers may damage the appliance's glass lid.

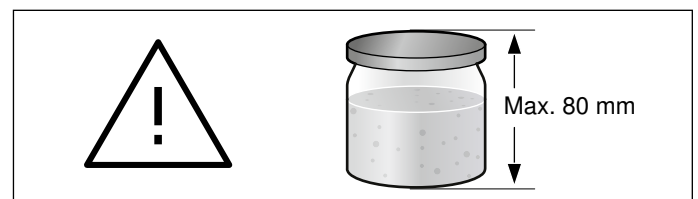

- Only use screw-top jars that are robust and intact.
- Only tighten the container by hand. The container is automatically sealed by the vacuum-sealing process.
- Not all jars or lids are suitable for being re-sealed under a vacuum. After the vacuuming process, check whether a vacuum has occurred: A lid that is curving inwards and can only be opened with a lot of force is an indication that the vacuuming process has worked. If the lid makes a "clicking" sound when it is pushed in and released and if it is easy to open, no vacuum has occurred. Repeat the vacuuming process or use more suitable screw-top jars.▮

Store food such as cheese, fish or garlic without any unpleasant odours. The hermetic sealing that takes place during vacuuming means that no unwanted odours can get out and the flavour cannot be absorbed by the other food.

Sealed vacuuming bags or vacuuming containers are the ideal means of transport for liquid foods. They are easy to handle, leak-proof and space-saving.

## Recommended settings

When stored appropriately, vacuumed food remains fresh for significantly longer. At higher vacuuming levels, the quality, appearance and ingredients of the food are better preserved.

The following table provides you with recommendations for the vacuumed levels for different foods. Observe the specific information on the recommended vacuuming levels and on preparing the food.

### Notes

- Only use fresh food. Check the quality of the food before vacuuming it.
- Only vacuum cold food – within a temperature range of 1 – 8 °C is best.
- Start at the lowest of the recommended vacuuming levels.
- Check the quality of the food after you remove it from storage. Do not use any food that is of dubious quality.

	Recommended vacuuming levels	Special instructions
<b>Food that is stored at room temperature (20 °C to 23 °C)</b>		
Baked goods	1, 2, 3	
Dried baked items/biscuits	1	
Tea/coffee	1, 2, 3	Store in a dark place
Rice/pasta	2	Vacuum in a container
Flour/semolina	1	
Nuts without shell	3	Store in a dark place
Dried fruits	3	
Crackers/chips	1, 2	Vacuum in a container
<b>Fresh food that has been frozen (-18 °C to -16 °C) or stored in a refrigerator (3 °C to 7 °C)</b>		
Fish	3	
Poultry	3	
Meat	3	
Whole sausage	3	
Sliced sausage	3	
Hard cheese	3	
Soft cheese	2	Vacuum in a container
Vegetables	2	Peel and blanch beforehand
Washed green salad	2	Vacuum in a container
Herbs	1, 2	Vacuum in a container
Fruit (hard)	3	
Fruit (soft)	2	Vacuum in a container Pre-frosting recommended
*Pre-frost the food laid out on a plate for approx. 1 hour to preserve its structure.		

## Cleaning

Only clean the appliance when it has been switched off.  
Ensure that the sealing bar in the vacuuming chamber has cooled down.

### **Warning**

#### **Risk of burns!**

The sealing bar in the vacuuming chamber becomes extremely hot if the appliance is used frequently and there are long heat-sealing times. Never touch the hot sealing bar. Keep children away from the appliance.

During cleaning, ensure that no water or other liquid gets into the vacuum-sealing compartment or, in particular, into the vacuum pump's air outlet. Never spray the inside or outside of the appliance with water.

Use a high-pressure cleaner or steam jet cleaner.

Only use natural cleaning agents, such as washing-up liquid and water. Do not use any abrasive materials or cleaning agents that contain alcohol.

Clean the appliance using only a damp cloth.

Do not use any abrasive sponges that may scratch or any glass scrapers.

**Note:** Leave the appliance and accessory parts to fully dry after they have been cleaned.

### **Glass front and glass lid**

Clean the glass front and the glass lid with glass cleaner and a soft cloth.

Do not use any abrasive sponges that may scratch or any glass scrapers.

### **Stainless steel vacuuming chamber**

Always remove flecks of limescale, grease, starch and albumin (e.g. egg white) immediately. Corrosion can form under these patches or splashes. Clean with water and some washing-up liquid. Dry the surface with a soft cloth.

### **Plastic control panel**

Do not use any abrasive sponges that may scratch or any glass scrapers.

### **Sealing bar**

Remove the remaining film from the sealing bar.

Never use abrasive cleaning agents to clean the sealing bar. Use a soft cloth.

The sealing bar is not suitable for dishwashers.

### **External vacuum-sealing adapter**

Wash the adapter by hand. It is not suitable for dishwashers.





### **Vacuum hose**

Rinse the vacuum hose by hand. It is not suitable for dishwashers.

## Trouble shooting

Faults often have simple explanations. Before you call our after-sales service, please read the information in the table below.

**Note:** Any repair work must only be carried out by qualified experts. Incorrect repairs to your appliance may present considerable risks for the user.

Fault	Error	Causes	Possible remedy
The  symbol will appear after a few seconds.	The vacuum cannot be created properly.	The glass lid has not been closed properly.	Open and close the glass lid again. When doing so, lightly press on the glass lid for the first few seconds.
		The seal on the glass lid is not fitted properly or is defective.	Check the seal.
		The seal on the glass lid has deformed.	Gently press the seal to straighten it out.
		The lid on the external vacuum-sealing container has not been closed properly.	Check the position of the vacuum-sealing lid. Only use suitable vacuum-sealing containers.
		The external vacuum-sealing connection is not positioned correctly on the vacuum-sealing chamber's air outlet.	Check the position of the external vacuum-sealing connection.
The  symbol will appear after the pump has been running for 2 minutes.	It is taking too long to create a vacuum. Your selected vacuum-sealing level cannot be reached.	As the temperature rises, liquids begin to boil. At this point, the process of creating a vacuum stops.	Only vacuum-seal cold liquids.
			If the vacuum-sealing chamber is wet, wipe it dry.
			Heat-seal the vacuum-sealing bag early if large bubbles form.
			Select a lower vacuum-sealing level.
The vacuum-sealing process will not start. The  symbol does not appear even though the lid is closed.	The appliance is not detecting the lid.	The door switch on the glass lid is missing or is not being detected by the appliance.	Call the after-sales service.
If you try to operate the appliance several times in succession, the vacuum-sealing process seems to run as normal but the bag is not heat-sealed.		The thermal switch on the heat-sealing transformer has been triggered.	Allow the appliance to cool for at least 10 minutes. Then try again. Allow the appliance to cool for at least 2 minutes between vacuum-sealing operations.
The vacuum-sealing process is taking longer and longer.		There is too much moisture in the pump system.	The appliance monitors the vacuum-sealing as it progresses. If too much liquid is retained in the pump oil, the  symbol will appear. Initiate drying.
		The pump system is extremely hot.	Allow the appliance to cool and then try again.
After the drying cycle has ended, the appliance is displaying the  and  symbols.		One drying cycle alone was not sufficient.	Wait until the  symbol is no longer lit up. Then start another drying cycle.

Fault	Error	Causes	Possible remedy
The vacuum in the plastic bag is not retained.	The bag is defective.	Sharp parts of the food (for example bones) may poke holes in the bag.	Check the bag for damage. Use a different bag if it is damaged. If the damage is caused by sharp-edged parts of the food, as far as possible, position these in the bag in such a way that they cannot damage the wall of the bag.
	The heat-sealed seam is defective.	The heat-sealing time you have selected is unsuitable for the plastic from which the bag is made.	Select a different heat-sealing time.
		There is liquid, grease or crumbs along the heat-sealed seam. The bag has creases along the heat-sealed seam.	Make sure that the bag is dry, that it has no creases, and that it is positioned fully on the heat-sealing bar. Use a different bag. Fold over the edge of the bag by 3 cm before you fill it.
The lid cannot be opened.		A slight vacuum has formed and it is holding the lid closed.	Do not use force or tools to open it. Initiate vacuum-sealing again and then cancel it immediately.
			Disconnect the appliance from the mains power supply. Wait 30 seconds and then start up the appliance again.
			Touch the  symbol for more than 5 seconds. The system is reset.

## Customer service

Our after-sales service is there for you if your appliance needs to be repaired. We will always find an appropriate solution, also in order to avoid after-sales personnel having to make unnecessary visits.

### E number and FD number

When calling us, please quote the full product number (E no.) and the production number (FD no.) so that we can provide you with the correct advice. The rating plate bearing these numbers can be found when you open the appliance door.

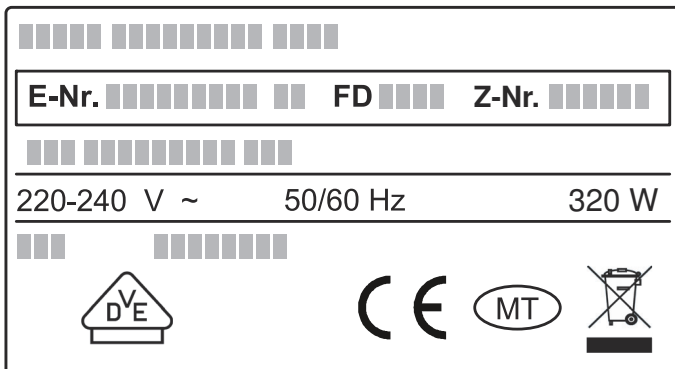

To save time, you can make a note of the numbers for your appliance and the telephone number of the after-sales service in the space below in case you need them.

**E no.**

**FD no.**

**After-sales service** 

Please note that a visit from an after-sales service engineer is not free of charge in the event that the appliance has been misused, even during the warranty period.

Please find the contact data of all countries in the enclosed customer service list.

### To book an engineer visit and product advice

**GB** 0344 892 8989

Calls charged at local or mobile rate.

**IE** 01450 2655

0.03 € per minute at peak. Off peak 0.0088 € per minute.

Rely on the professionalism of the manufacturer. You can therefore be sure that the repair is carried out by trained service technicians who carry original spare parts for your appliances.

## Technical specifications

Power supply:	220-240 V 50/60 Hz
Total connected load:	320 W
VDE approved:	Yes
CE mark:	Yes



Constructa Neff  
Vertriebs-GmbH  
Carl-Wery-Straße 34  
D-81739 München

Register your product online

[www.neff-international.com](http://www.neff-international.com)



9001274738

970419