



Built-in oven C17E64.3



en Table of contents

Important safety information	4	Low-temperature cooking	21
Causes of damage	5	Using Low-temperature cooking.....	21
Energy and environment tips	5	Table for Low-temperature cooking	21
Saving energy.....	5	Tips and tricks.....	22
Environmentally-friendly disposal.....	5	Defrosting	22
Your new appliance	6	Defrosting with CircoTherm®.....	22
Control panel	6	Defrost	22
Operating modes.....	6	Preserve	23
Your accessories	7	Cleaning and care	23
Accessories	7	Cleaning the appliance exterior.....	24
Inserting accessories	7	Cleaning the cooking compartment.....	24
Shelf positions.....	7	Self-cleaning surface.....	24
Optional accessories	8	EasyClean®.....	25
Before using the appliance for the first time	8	Removing and fitting the appliance door.....	25
Setting the language	8	Cleaning the door panels.....	26
Setting the clock.....	8	Cleaning the cooking compartment ceiling.....	27
Cleaning the appliance.....	8	Cleaning the hook-in racks.....	27
Operating the appliance	9	Cleaning the telescopic shelves.....	27
Switching on the appliance.....	9	Faults and repairs	27
Switching off the appliance.....	9	Replacing the oven light bulb	29
Changing the basic settings.....	9	Changing the door seal.....	29
Automatic safety cut-out.....	10	After-sales service	29
Electronic clock	10	E number and FD number.....	29
Clock display	10	Test dishes	30
Timer	11		
Cooking time	11		
End of operation	11		
Preset operation.....	11		
Setting the clock.....	11		
Rapid heat up.....	12		
Checking, correcting or deleting settings	12		
Childproof lock	12		
Lock.....	12		
Permanent lock	12		
Baking	13		
Baking in tins and on trays	13		
Baking on two or more levels	13		
Baking table for basic doughs/cake mixtures	13		
Bread-baking	14		
Baking table for fresh meals and frozen convenience products	15		
Tips and tricks.....	16		
Roasting	16		
Open roasting.....	16		
Closed roasting.....	17		
Roasting table	17		
Tips and tricks.....	18		
Grilling	18		
Circo-roasting	18		
Radiant grilling	19		
Steam cooking	20		
Dough proving	20		
Yeast dough.....	20		
Yoghurt	21		

Additional information on products, accessories, replacement parts and services can be found at www.neff-international.com and in the online shop www.neff-eshop.com

Important safety information

Read these instructions carefully. Only then will you be able to operate your appliance safely and correctly. Retain the instruction manual and installation instructions for future use or for subsequent owners.

This appliance is only intended to be fully fitted in a kitchen. Observe the special installation instructions.

Check the appliance for damage after unpacking it. Do not connect the appliance if it has been damaged in transport.

Only a licensed professional may connect appliances without plugs. Damage caused by incorrect connection is not covered under warranty.

This appliance is intended for domestic use only. The appliance must only be used for the preparation of food and drink. The appliance must be supervised during operation. Only use this appliance indoors.

This appliance may be used by children over the age of 8 years old and by persons with reduced physical, sensory or mental capacity or by persons with a lack of experience or knowledge if they are supervised or are instructed by a person responsible for their safety how to use the appliance safely and have understood the associated hazards.

Children must not play with the appliance. Children must not clean the appliance or carry out general maintenance unless they are at least 8 years old and are being supervised.

Keep children below the age of 8 years old at a safe distance from the appliance and power cable.

Always slide accessories into the cooking compartment correctly. See "*Description of accessories*" in the instruction manual.

Risk of fire!

- Combustible items stored in the cooking compartment may catch fire. Never store combustible items in the cooking compartment. Never open the appliance door if there is smoke inside. Switch off the appliance and unplug it from the mains or switch off the circuit breaker in the fuse box.

- A draught is created when the appliance door is opened. Greaseproof paper may come into contact with the heating element and catch fire. Do not place greaseproof paper loosely over accessories during preheating. Always weight down the greaseproof paper with a dish or a baking tin. Only cover the surface required with greaseproof paper. Greaseproof paper must not protrude over the accessories.

Risk of burns!

- The appliance becomes very hot. Never touch the interior surfaces of the cooking compartment or the heating elements. Always allow the appliance to cool down. Keep children at a safe distance.
- Accessories and ovenware become very hot. Always use oven gloves to remove accessories or ovenware from the cooking compartment.
- Alcoholic vapours may catch fire in the hot cooking compartment. Never prepare food containing large quantities of drinks with a high alcohol content. Only use small quantities of drinks with a high alcohol content. Open the appliance door with care.

Risk of scalding!

- The accessible parts become hot during operation. Never touch the hot parts. Keep children at a safe distance.
- When you open the appliance door, hot steam may escape. Open the appliance door with care. Keep children at a safe distance.
- Water in a hot cooking compartment may create hot steam. Never pour water into the hot cooking compartment.

Risk of injury!

Scratched glass in the appliance door may develop into a crack. Do not use a glass scraper, or sharp or abrasive cleaning aids or detergents.

Risk of electric shock!

- Incorrect repairs are dangerous. Repairs may only be carried out by one of our trained after-sales engineers. If the appliance is faulty, unplug the mains plug or switch off the fuse in the fuse box. Contact the after-sales service.
- The cable insulation on electrical appliances may melt when touching hot parts of the appliance. Never bring electrical appliance cables into contact with hot parts of the appliance.
- Penetrating moisture may cause an electric shock. Do not use any high-pressure cleaners or steam cleaners.
- When replacing the cooking compartment bulb, the bulb socket contacts are live. Before replacing the bulb, unplug the appliance from the mains or switch off the circuit breaker in the fuse box.
- A defective appliance may cause electric shock. Never switch on a defective appliance. Unplug the appliance from the mains or switch off the circuit breaker in the fuse box. Contact the after-sales service.

Causes of damage

Caution!

- Accessories, foil, greaseproof paper or ovenware on the cooking compartment floor: do not place accessories on the cooking compartment floor. Do not cover the cooking compartment floor with any sort of foil or greaseproof paper. Do not place ovenware on the cooking compartment floor if a temperature of over 50 °C has been set. This will cause heat to accumulate. The baking and roasting times will no longer be correct and the enamel will be damaged.
- Water in a hot cooking compartment: do not pour water into the cooking compartment when it is hot. This will cause steam. The temperature change can cause damage to the enamel.
- Moist food: do not store moist food in the cooking compartment when it is closed for prolonged periods. This will damage the enamel.
- Fruit juice: when baking particularly juicy fruit pies, do not pack the baking tray too generously. Fruit juice dripping from the baking tray leaves stains that cannot be removed. If possible, use the deeper universal pan.
- Cooling with the appliance door open: only allow the cooking compartment to cool when it is closed. Even if the appliance door is only open a little, front panels of adjacent units could be damaged over time.
- Very dirty door seal: If the door seal is very dirty, the appliance door will no longer close properly when the appliance is in use. The fronts of adjacent units could be damaged. Always keep the door seal clean.
- Appliance door as a seat, shelf or worktop: Do not sit on the appliance door, or place or hang anything on it. Do not place any cookware or accessories on the appliance door.
- Inserting accessories: depending on the appliance model, accessories can scratch the door panel when closing the appliance door. Always insert the accessories into the cooking compartment as far as they will go.
- Carrying the appliance: do not carry or hold the appliance by the door handle. The door handle cannot support the weight of the appliance and could break.

Energy and environment tips

Here you can find tips on how to save energy when baking and roasting and how to dispose of your appliance properly.

Saving energy

Only preheat the oven if this is specified in the recipe or in the operating instruction tables.

Use dark, black lacquered or enamelled baking tins. They absorb the heat particularly well.

Open the appliance door as little as possible during cooking, baking or roasting.

It is best to bake several cakes one after the other. The cooking compartment is still warm. This may reduce the baking time for the second cake.

For longer cooking times, you can switch the oven off 10 minutes before the end of the cooking time and use the residual heat to finish cooking.

Environmentally-friendly disposal

Dispose of packaging in an environmentally-friendly manner.



This appliance complies with European Directive 2002/96/EC on Waste Electrical and Electronic Equipment (WEEE). The directive gives a framework for the collection and recycling of old appliances, which is valid across the EU.

Your new appliance

In this section, you will find information on

- the control panel
- the operating modes

Control panel

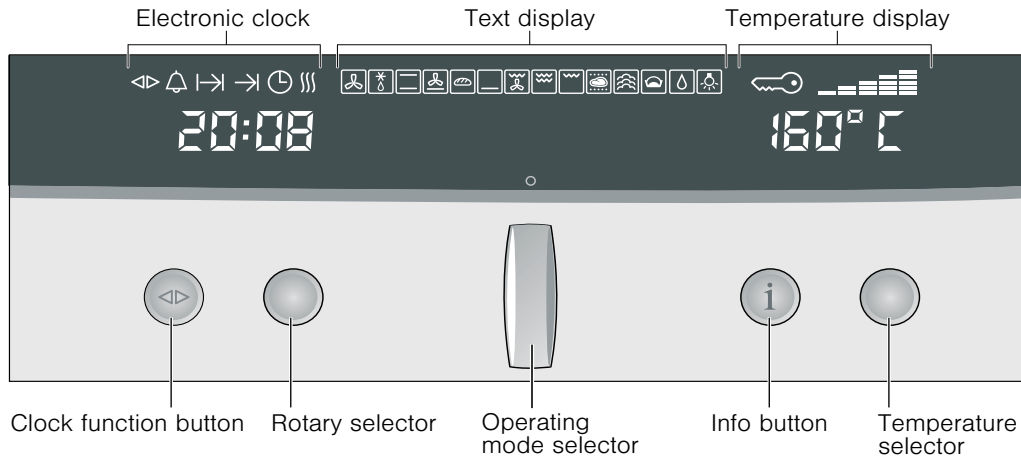

Control element	Use
◀▶	Clock function button Selects the required clock function or Rapid heat up (see section: Electronic clock)
	Rotary selector Makes settings within a clock function or activates Rapid heat up (see section: Electronic clock)
	Operating mode selector Selects the desired operating mode (see section: Switching on the appliance)
i	Info button When the appliance is switched on: displays the current oven temperature during the heating up phase (see section: Switching on the appliance) When the appliance is switched off: calls up the basic settings menu (see section: Changing the basic settings)
	Temperature selector When the appliance is switched on: sets the temperature (see section: Switching on the appliance) When the appliance is switched off: changes the settings in the basic settings menu (see section: Changing the basic settings)





Pop-out operating knob

The rotary, temperature and operating mode selectors can all be popped out. Push the required operating knob to pop it in or out.

Operating modes

Here is an overview of the operating modes of your appliance.

Operating mode	Used for
☞	CircoTherm® For baking and roasting on one or more levels
☞	Defrost setting For gentle defrosting of pieces of meat, bread and delicate pastries (e.g. cream gateau)
☞	Top/bottom heating For baking and roasting on one level. Especially suitable for cakes with moist toppings (e.g. cheesecake)
☞	CircoTherm intensive For frozen ready-made products and dishes which require a lot of heat from underneath. (see section: Baking)
☞	Bread-baking For baked goods which need to be baked at high temperatures
☞	Bottom heat For food and baked goods which should form a crust or need more browning on the underside. Only activate bottom heat for a short while at the end of the baking time.
☞	Circo-roasting For poultry and larger pieces of meat
☞	Full-surface grill For large amounts of flat, small items for grilling (e.g. steaks, sausages)
☞	Centre area grill For small amounts of flat, small items for grilling (e.g. steaks, bread)
☞	Slow cook For tender pieces of meat, that are to be cooked medium/medium-rare or à point

Operating mode	Used for
 Steam cooking	For gentle preparation of vegetables, meat and fish
 Dough proving	For preparing yeast dough and yoghurt
 EasyClean®	Makes cleaning the cooking compartment easier
 Interior lighting	Provides assistance when maintaining and cleaning the cooking compartment

Your accessories

In this section, you will find information on

- Your accessories
- the correct way to insert the accessories into the cooking compartment
- the shelf positions
- the optional accessories

Accessories

The following accessories are included with your appliance:



Baking tray, enameled
for baking tray bakes and small items



Wire rack
for baking in baking tins, roasting in roasting dishes and grilling



Universal pan, enameled
for baking moist cakes, roasting, grilling and collecting drops of liquid during cooking

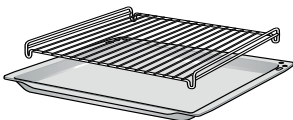

Insert grid
for roasting and grilling

Note: The wire insert is always used together with the universal pan. In this combination, the wire insert is placed in the universal pan.

Note: The baking tray and universal pan may become distorted when the appliance is in operation. This is caused by the considerable temperature differences acting on the accessories. These differences may occur if only a part of the accessory is covered with food, or if frozen items such as pizza are placed on the accessory.

Inserting accessories

The accessories are equipped with a locking function. The locking function prevents the accessories from tilting when they are pulled out. The accessories must be inserted into the cooking compartment correctly for the tilt protection to work properly.

When inserting the wire rack, check

- that the lug (a) is pointing downwards
- that the lug (a) is in the rear part of the wire rack

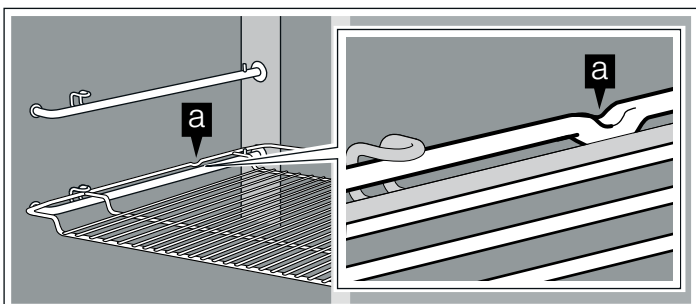

When inserting the baking tray or the universal pan, check

- that the lug (a) is in the rear part of the accessory
- that the sloping edge of the accessory faces towards the appliance door when it is inserted

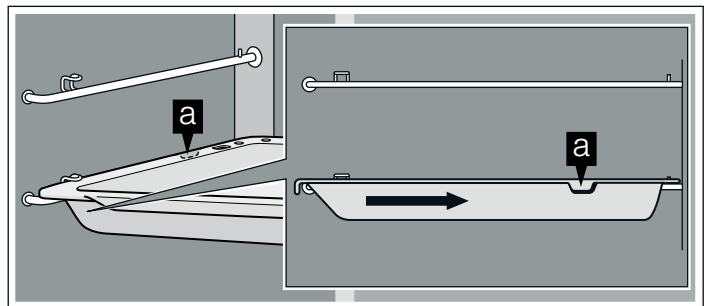

Shelf positions

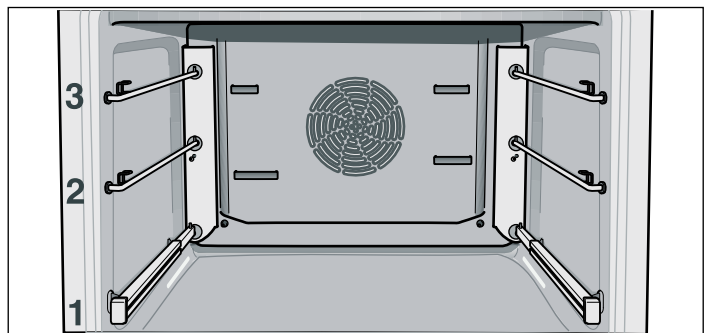

The cooking compartment has three shelf positions. The shelf positions are counted from the bottom up. They are marked in the cooking compartment.

Risk of burns!

The telescopic shelves become hot when the appliance is in use. Take special care not to get burnt when they are pulled out.

The individual shelf units can be inserted into your preferred shelf positions. This simple insertion system allows flexible and quick handling when changing shelves.

Note: Do not use shelf height 2 when baking and roasting with CircoTherm®. This will adversely affect air circulation and your baking and roasting results will not be as good.

Optional accessories

You can purchase optional accessories from the after-sales service or specialist retailers. A comprehensive range of products for your appliance can be found in our brochures or on our home page.

Accessories	Ordering no.
Mega system steamer	N8642X3
Universal pan, enamelled	Z1232X3
Universal pan, non-stick	Z1233X3
Extra-deep pan, enamelled	Z1272X0

Accessories	Ordering no.
Baking tray, aluminium	Z1332X0
Baking tray, enamelled	Z1342X0
Baking tray, non-stick	Z1343X0
Pizza tray	Z1352X0
Baking and roasting wire rack	Z1432X3
Roasting tray, enamelled, two-piece	Z1512X0
VarioCLOU® telescopic shelf with full extension	Z1785X3

Before using the appliance for the first time

In this section, you can read about

- how to set the language
- how to set the time
- How to clean your appliance before using it for the first time

Setting the language

Once the appliance has been connected to the power supply, you must set the language for the text display.

1. Turn the temperature selector until the language you require appears on the text display.
2. Press and hold the **i** info button for 3 seconds. Your setting is saved.

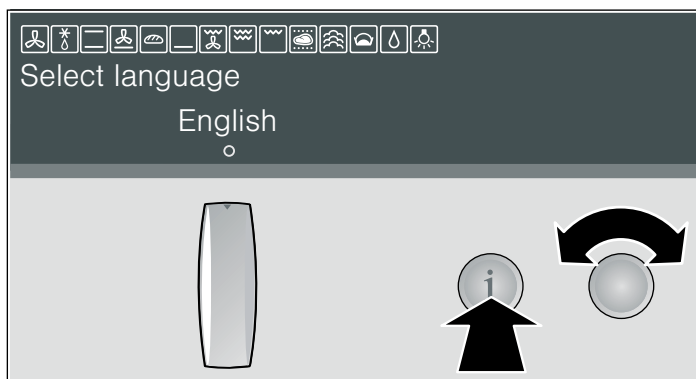

Changing the language

Your appliance must be switched off.

1. Press and hold the **i** info button for 3 seconds. This takes you directly to the language selection screen.
2. Turn the temperature selector until the language you require appears on the text display.
3. Press and hold the **i** info button for 3 seconds. Your setting is saved.

Setting the clock

Note: When you press the **<>** clock function button, you have 3 seconds to set the clock using the rotary selector. Should this have been insufficient for you, you can amend the clock time later.

0:00 flashes in the clock display.

1. Briefly press the **<>** clock function button to go to the setting mode. The **<>** and **⌚** symbols light up. **12:00** appears in the clock display.
2. Set the current time using the rotary selector. Your setting is accepted after 3 seconds.

Changing the clock

To subsequently change the time, press the **<>** clock function button repeatedly until the **<>** and **⌚** symbols light up again. Change the time with the rotary selector.



Cleaning the appliance

Clean your appliance before using it for the first time.

1. Remove the accessories from the cooking compartment.
2. Completely remove any residual packaging (e.g. chips of polystyrene) from the cooking compartment.
3. Clean the accessories and cooking compartment with hot soapy water (see section: Cleaning and care).
4. Heat with **☐** Top/bottom heat at 240 °C for 60 minutes.
5. Afterwards, wipe the cooled cooking compartment with hot, soapy water.
6. Clean the outside of the appliance with a soft, damp cloth and soapy water.

Operating the appliance

In this section, you can read about

- how to switch your appliance on and off
- how to select an operating mode and temperature
- how you can change the basic settings
- when your appliance switches off automatically

Switching on the appliance

1. Turn the operating mode selector until the desired operating mode appears on the text display.
A default temperature appears on the temperature display.
2. Turn the temperature selector to change the default temperature.
The appliance begins heating.

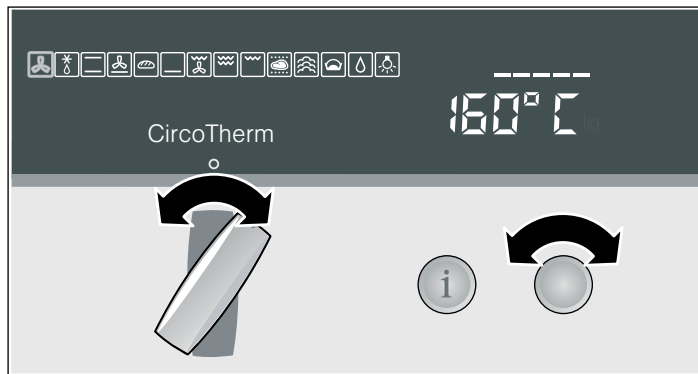

Notes

- The Low-temperature cooking, Steam cooking, Dough proving and EasyClean® operating modes can only be started if neither **H** nor **h** is displayed in the temperature display.
- If no default temperature is displayed, the temperature of your selected operating mode is a fixed setting. You cannot change this temperature.

Operating mode	Default temperature in °C	Temperature range in °C
CircoTherm®	160	40 - 200
Defrost	Fixed setting	
Top/bottom heat	170	50 - 275
CircoTherm intensive	220	50 - 275
Bread-baking	200	180 - 220
Bottom heat	200	50 - 225
Circo-roasting	170	50 - 250
Full-surface grill	220	50 - 275
Full-surface grill (intensive)*	Fixed setting	
Centre area grill	180	50 - 275
Centre-area grill (intensive)*	Fixed setting	
Slow cook	Fixed setting	
Steam cooking	Fixed setting	
Dough proving	Fixed setting	
EasyClean®	Fixed setting	
Interior lighting	Fixed setting	

* Turn the temperature selector beyond 275 °C. **int** appears in the temperature display

Current temperature

Press the **i** info button. The current temperature appears for 3 seconds.

Note: The current temperature can only be displayed with operating modes with a default temperature.

Heating indicator

The heating indicator displays the rising temperature in the cooking compartment.

- Temperature reached (figure A)
- Appliance reheating (figure B)

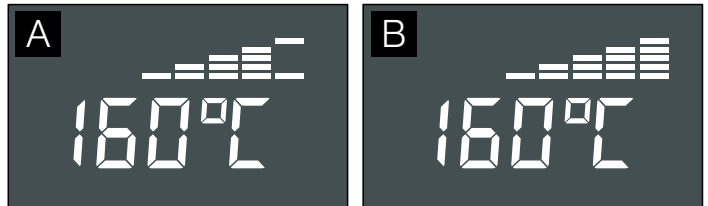

Switching off the appliance

Turn the operating mode selector to the **o** position. The appliance is switched off.

The appliance has a cooling fan. After the appliance is switched off, the cooling fan may continue to run.

You can see in the temperature display whether there is high or low residual heat in the cooking compartment.

Temperature display	Text display	Meaning
H	Residual heat high	Residual heat high (above 120 °C)
h	Residual heat low	Residual heat low (between 60 °C and 120 °C)

Changing the basic settings

Your appliance has various basic settings, which are preset at the factory. You can, however, change these basic settings as required.

The appliance must be switched off.

1. Press and hold the **i** info button for 3 seconds to go to the basic settings menu.
The text display shows "Select language: German". If the appliance controls are locked, you must unlock them first.
2. Press the **i** info button repeatedly until the current basic setting for the relevant submenu is displayed on the text display (e.g. "Audible signal off").
3. Using the temperature selector, set the required basic setting within a submenu (e.g. "Audible signal 2 minutes").
4. Press and hold the **i** info button for 3 seconds.
Your basic setting is saved.

You can change the following basic settings:

Basic settings menu		
Submenu	Basic setting	Setting symbol
Language	Select language English	
Childproof lock	Appliance controls unlocked	c 10
	Appliance controls locked	c 11
	Appliance permanently locked	c 21
Audible signal	Audible signal off	c 10
	Audible signal 30 seconds	c 31
	Audible signal 2 minutes	c 32
	Audible signal 10 minutes	c 33

Automatic safety cut-out

The automatic safety cut-out is only activated if you have not made any settings on your appliance for a prolonged period.

You can adjust the period of time after which your appliance shuts off.

"Safety cut-out" appears in the text display and 000 flashes in the temperature display. Appliance operation is interrupted.

Turn the operating mode selector to the 0 position to deactivate it.

Electronic clock

In this section, you can read about

- how to set the timer
- how to switch your appliance off automatically (cooking time and end of operation)
- how to switch your appliance on and off automatically (preset operation)
- how to set the time
- find out how to activate rapid heat up

Clock display



Clock function	Use
Timer	You can use the minute minder as an egg timer or a kitchen timer. The appliance does not switch on or off automatically
Cooking time	The appliances switches off automatically after a cooking time setting has elapsed (e.g. 1:30 hours)
End of operation	The appliance switches off automatically at a set time (e.g. 12:30)
Preset operation	The appliance switches on and off automatically. Cooking time and end of operation have been combined.
Clock	Setting the clock
Rapid heat up	Shortens the heat up time



Notes

- Between the times 22:00 and 5:59 the clock display is dimmed if you do not make any settings in that period or no clock function is activated.
- When you set a clock function, the time interval increases when you set higher values (e.g. cooking time up to 1:00h to the minute, using 1:00h to the nearest 5 minutes).
- For the minute minder, cooking time, end of operation and preselection mode clock functions, a signal sounds when the settings have elapsed and the or symbol flashes. To cancel the audible signal before it ends, press the clock function button.
- Briefly press the clock function button to select a clock function. You then have 3 seconds to set the selected clock function. After this time, the setting mode is exited automatically.

Switching the clock display on and off

1. Press and hold the clock function button for 6 seconds. The clock display switches off. If a clock function is active, the associated symbol remains lit.
2. Press the clock function button briefly. The clock display switches on.



Timer

1. Press the  repeatedly until the  and  symbols light up.
2. Set the duration using the rotary selector (e.g. **5:00** minutes).
The setting is applied automatically. Then the clock is displayed again and the minute minder starts counting down.



Cooking time

Automatic switch-off after a cooking time setting has elapsed.

1. Set the operating mode and temperature.
The appliance heats up.
2. Press the  repeatedly until the  and  symbols light up.
3. Set the cooking time with the rotary selector (e.g. **1:30** hours).
The setting is applied automatically. The time is then displayed again and the set cooking time counts down.





Once the cooking time has elapsed, the appliance switches off automatically.

1. Turn the operating mode and temperature selector back to the 0 position.
2. Press the  clock function button to exit the clock function.

End of operation

Automatic switch-off at a set time.

1. Set the operating mode and temperature.
The appliance heats up.
2. Press the  clock function button repeatedly until the  and  symbols light up.
3. Set the end of operation using the rotary selector (e.g. **12:30** o'clock).
The setting is applied automatically. The clock is then displayed again.









The appliance switches off automatically at the time set for the end of operation.

1. Turn the operating mode and temperature selector back to the 0 position.
2. Press the  clock function button to exit the clock function.

Preset operation



The appliance switches on automatically, then switches off automatically at the time preselected for the end of operation. To set this function, combine the cooking time and end of operation clock functions.

Bear in mind that food which spoils easily should not be left in the cooking compartment for too long.

1. Set the operating mode and temperature.
The appliance heats up.
2. Press the  clock function button repeatedly until the  and  symbols light up.
3. Set the cooking time with the rotary selector (e.g. **1:30** hours).
The setting is applied automatically.
4. Press the  clock function button repeatedly until the  and  symbols light up.
5. Set the end of operation using the rotary selector (e.g. **12:30** o'clock).
The appliance switches off and waits until the appropriate time to switch on (**11:00** in the example). The appliance switches off automatically at the time set for the end of operation (**12:30**).
6. Turn the operating mode and temperature selector back to the 0 position.
7. Press the  clock function button to exit the clock function.



Setting the clock

You can only change the clock when no other clock function is active.







1. Press the  clock function button repeatedly until the  and  symbols light up.
2. Set the clock using the rotary selector.
The setting is applied automatically.





Rapid heat up

You can reduce the heating up time for the  CircoTherm® and  Bread-baking operating modes if the set temperature is higher than 100 °C.

Note: During Rapid heat up, do not place any food in the cooking compartment for as long as the  symbol is lit.

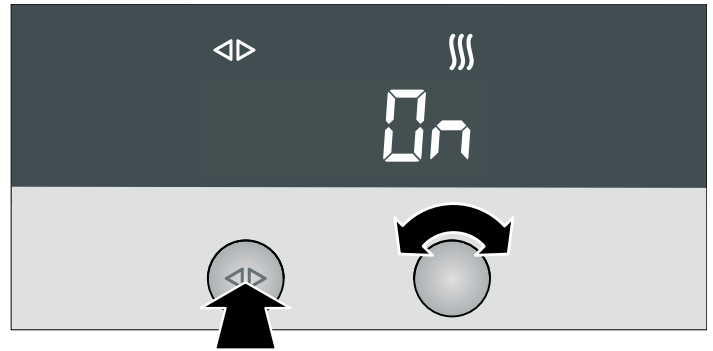
1. Set the operating mode and temperature.
The appliance heats up.
2. Press the  clock function button until the  and  symbols light up and  appears in the clock display.
3. Turn the rotary selector clockwise.
 is displayed in the clock display and the  symbol lights up. Rapid heat up is activated.



After reaching the set temperature, Rapid heat up switches off. The  symbol goes out.

Checking, correcting or deleting settings

1. To check your settings, press the  clock function button repeatedly until the corresponding symbol lights up.
2. If necessary, you can correct your setting using the rotary selector.
3. If you wish to cancel your setting, turn the rotary selector anti-clockwise to the original value.

Childproof lock

In this section, you can read about







- how to lock your appliance
- how to lock your appliance permanently

Lock

Once it has been locked, the appliance cannot be switched on accidentally or by unauthorised users (e.g. by children playing).





To switch the appliance on again, you must unlock it. After appliance operation, the appliance is not automatically locked. Lock it again if necessary or activate the permanent lock.

Lock appliance

1. Switch off the appliance.
2. Press and hold the  info button for 3 seconds to go to the basic settings menu.
3. Press the  info button briefly and repeatedly until  appears in the temperature display.
4. Turn the temperature selector until  appears on the temperature display.
5. Press and hold the  info button until the  symbol appears in the temperature display.

Note: If you try to switch on the locked appliance,  appears on the temperature display and “controls locked” appears on the text display.

Unlocking the appliance







1. Press and hold the  info button until  appears in the temperature display.
2. Turn the temperature selector until  appears on the temperature display.
3. Press and hold the  info button until the  symbol goes out.

Permanent lock

Once it has been permanently locked, the appliance cannot be switched on accidentally or by unauthorised users (e.g. by children playing).





To switch the appliance on, you must interrupt the permanent lock briefly. After you have switched your appliance off, it locks again automatically.

Locking the appliance permanently

1. Switch off the appliance.
2. Press and hold the  info button for 3 seconds to go to the basic settings menu.
3. Press the  info button briefly and repeatedly until  appears in the temperature display.
4. Turn the temperature selector until  appears on the temperature display.
5. Press and hold the  info button for 3 seconds.
Your appliance will be locked after 30 seconds. The  symbol appears in the temperature display

Note: If you try to switch on the locked appliance,  appears on the temperature display and “Appliance permanent lock” appears on the text display.

Interrupting permanent lock

1. Press and hold the  info button until  appears in the temperature display.
2. Turn the temperature selector until  appears on the temperature display.
3. Press and hold the  info button until the  symbol goes out.
The permanent lock is interrupted.
4. Switch the appliance on within 30 seconds.
After the permanent lock is switched off, it is reactivated after 30 seconds.

Unlocking the appliance permanently

1. Press and hold the **i** info button until **⌂** appears in the temperature display.
2. Turn the temperature selector until **⌂** appears on the temperature display.
3. Press and hold the **i** info button until the **↔** symbol goes out.

4. Within 30 seconds, press and hold the **i** info button again for 3 seconds to go to the basic settings menu.
5. Press the **i** info button briefly and repeatedly until **⌂** appears in the temperature display.
6. Turn the temperature selector until **⌂** appears on the temperature display.
7. Press and hold the **i** info button for 3 seconds. The appliance is permanently unlocked.

Baking

In this section, you will find information on

- Baking tins and trays
- Baking on two or more levels
- Baking basic doughs and cake mixtures (baking table)
- Baking pre-prepared frozen products and freshly prepared meals (baking table)
- Tips and tricks for baking

Note: Do not use shelf height 2 when baking with **⌂** CircoTherm®. The air circulation would be impaired and this will have a negative effect on your baking.

Baking in tins and on trays

Baking tins

We recommend that you use dark-coloured metal baking tins.

Tinplate and glass dishes increase the baking time required and the cake will not brown evenly. If you wish to bake using tinplate tins and **☐** Top/bottom heat, you should use shelf position 1.

If you wish to use silicone baking tins, use the information and recipes provided by the manufacturer as a guide. Silicone baking tins are often smaller than normal tins. The amount of mixture and recipe instructions may differ.

If you are baking on one level with **⌂** CircoTherm®, always place a loaf tin diagonally and a round tin in the centre of the wire rack.

Baking trays

We recommend that you only use original baking trays, as these have been optimally designed for the cooking compartment and the operating modes.

Always slide the baking tray or the universal pan in carefully as far as it will go and make sure that the sloping edge is facing the appliance door.

Use the universal pan if you are baking moist cakes, so that the cooking compartment does not get dirty.

Baking on two or more levels

If you are baking on several levels, you should preferably use baking trays and insert these at the same time.

Bear in mind that your items may brown at different rates on each level. The items on the top level will brown more quickly and can be taken out earlier.

If you wish to bake on two levels using a baking tray and a universal pan, you should insert the baking tray at shelf height 3 and the universal pan at shelf height 1.

Baking table for basic doughs/cake mixtures

The values in the table are guidelines and apply to enamelled baking trays and dark baking tins. The values may vary depending on the type and amount of dough/mixture and on the baking tin.



We recommend that you set the lower of the specified temperatures the first time. Lower temperatures will generally allow more even browning.

If you are baking according to your own recipe, use similar recipes in the table as a guide.



Observe the notes in the table about preheating.

Basic dough	CircoTherm® ⌂			☐ Top/bottom heat	
	Shelf height	Temperature in °C	Baking time in minutes	Shelf height	Temperature in °C
Rich sponge mixture					
Tray bakes with topping	1	160 - 170	30 - 40	2	160 - 170
	1 + 3	150 - 160	40 - 50	-	-
Springform cake tin/loaf tin	1	150 - 160	60 - 80	1	160 - 170
Flan tin	1	160 - 170	20 - 35	1	170 - 180
Shortcrust pastry					
Tray bake with dry topping, e.g. crumble	1	160 - 170	45 - 65	2	170 - 180
	1 + 3	160 - 170	60 - 75	-	-
Tray bake with moist topping, e.g. egg custard	1	150 - 170	65 - 85	-	-
Springform cake tin, e.g. sponge base cheesecake	1	160 - 170	50 - 90	1	170 - 180
Flan tin	1	160 - 170*	20 - 35	1	190 - 200*

* Preheat oven

Basic dough	CircoTherm® 			Top/bottom heat 	
	Shelf height	Temperature in °C	Baking time in minutes	Shelf height	Temperature in °C
Sponge mixture					
Swiss roll	1	180 - 190*	10 - 15	2	200 - 210*
Flan tin	1	160 - 170	20 - 30	1	170 - 180
Sponge (6 eggs)	1	150 - 160	30 - 45	1	160 - 170
Sponge (3 eggs)	1	160 - 170*	20 - 35	1	170 - 180*
Yeast dough					
Tray bake with dry topping, e.g. crumble	1	160 - 170	50 - 65	2	170 - 180
	1 + 3	160 - 170	60 - 70	-	-
Savarin/plaited loaf (500 g)	1	160 - 170	30 - 45	2	170 - 180
Springform cake tin	1	160 - 170	30 - 45	1	170 - 180
Ring cake tin	1	160 - 170	30 - 45	1	170 - 180

* Preheat oven

Small baked products	CircoTherm® 			Top/bottom heat 	
	Shelf position	Temperature in °C	Baking time in minutes	Shelf position	Temperature in °C
Yeast dough	1	160 - 170	20 - 25	2	160 - 170
	1 + 3	160 - 170	20 - 30	-	-
Meringue mixture	1	80	100 - 130	2	80 - 90
	1 + 3	80	120 - 150	-	-
Puff pastry	1	180 - 200*	20 - 30	2	200 - 210*
	1 + 3	180 - 200*	25 - 35	-	-
Choux pastry	1	180 - 200*	25 - 35	2	200 - 210*
	1 + 3	180 - 200*	25 - 35	-	-
Sponge mixture, e.g. muffins	1	150 - 160*	20 - 30	1	170 - 180*
	1 + 3	160 - 170*	25 - 35	-	-
Shortcrust pastry, e.g. butter biscuits	1	140 - 150*	15 - 20	2	140 - 150*
	1 + 3	140 - 150*	15 - 20	-	-

* Preheat oven



Bread-baking

The information in the table contains only guide values. It may vary depending on the type and amount of dough.

The values for bread dough apply to both dough placed on a tray and dough placed in a loaf tin.

You should set the lower of the specified temperatures the first time. Lower temperatures will generally allow more even browning.

Please note the information about preheating in the table.

Bread	Bread-baking 			Top/bottom heat 	
	Shelf height	Temperature in °C	Baking time in minutes	Shelf height	Temperature in °C
Bread rolls	1	220*	20 - 30	1	240*
Flatbread	1	220*	10 - 20	1	240*
Pasty	1	220*	30 - 40	1	240*
Bread dough 750 - 1,000 g					
Final baking	1	220*	35 - 40	2	220*
Bread dough 1,000 - 1,250 g					
Initial baking	1	220*	10 - 15	2	240*
Final baking	1	180	40 - 45	2	200

* Preheat oven

Bread	Bread-baking			Top/bottom heat	
	Shelf height	Temperature in °C	Baking time in minutes	Shelf height	Temperature in °C
Bread dough 1,250 - 1,500 g					
Initial baking	1	220*	10 - 15	2	240*
Final baking	1	180	40 - 50	2	200

* Preheat oven

Baking table for fresh meals and frozen convenience products

Circotherm intensive  is particularly suitable for freshly prepared dishes that require a lot of heat from underneath and for frozen convenience products.

Notes

- Use the universal pan for frozen products
- Line the universal pan with greaseproof paper or with special grease absorbing paper if you are baking frozen potato products
- Only use greaseproof paper that is suitable for the selected temperature
- Spread chips out in a single layer
- Turn frozen potato products half way through the baking time
- Only season frozen potato products after they have finished baking

- Leave a little space between bread rolls when crisping them up. Do not place too many on a baking tray
- Do not use frozen products with freezer burn
- Do not use frozen products that are heavily frosted
- Follow the manufacturer's instructions.
- You cannot bake on more than one level with CircoTherm intensive

The values in the table are guidelines and apply to enamelled baking trays. The values may vary depending on the type and amount of dough/mixture and on the baking tin.

We recommend that you set the lower of the specified temperatures the first time. Lower temperatures will generally allow more even browning.

If you are baking according to your own recipe, use similar recipes in the table as a guide.

Observe the notes in the table about preheating.

Meals	Bread-baking			Circotherm intensive 	
	Shelf position	Temperature in °C	Baking time in minutes	Shelf position	Temperature in °C
Pizza, fresh	1	210 - 220*	25 - 35	1	200 - 220*
	1 + 3	180 - 190	40 - 50	-	-
Savoury flan	1	220*	10 - 20	1	200 - 220*
Quiche	1	180 - 190	45 - 60	1	190 - 210
Tart	1	190 - 200*	35 - 45	1	210 - 230
Swiss flan	1	180 - 190*	45 - 55	1	180 - 200
Potato gratin made from raw potatoes			50 - 60	1	170 - 180
Strudel, frozen	1	180 - 200	35 - 45	1	180 - 200
Pizza, frozen					
Pizza with thin base	1	180 - 200	15 - 25	1	200 - 220
Pizza with deep-pan base	1	180 - 200	20 - 30	1	190 - 210
Potato products, frozen					
Chips	1	190 - 210	20 - 30	1	200 - 220
Croquettes	1	180 - 200	25 - 35	1	190 - 210
Baked goods					
Part-baked bread rolls/baguettes	1	190 - 210	5 - 15	1	180 - 200
Bread rolls/baguette, frozen	1	190 - 210	5 - 15	1	180 - 200
Bread rolls/baguette, part baked, frozen	1	190 - 210	10 - 20	1	180 - 200
Pretzel dough, frozen	1	190 - 210	15 - 25	1	180 - 200
Processed portions, frozen					
Fish fingers	1	180 - 200	15 - 25	1	190 - 210
Veggie burgers	1	180 - 200	20 - 30	1	180 - 200

* Preheat oven

Tips and tricks

The cake is too light in colour	Check the shelf height. Check whether you have used the bakeware that we have recommended. Place your tin on the wire rack and not on the baking tray. If the shelf height and the bakeware are correct, then you should either extend the baking time or increase the temperature.
The cake is too dark	Check the shelf height. If the shelf height is correct, you should either shorten the baking time or reduce the temperature.
The cake is unevenly browned in the baking tin	Check the shelf height. Check the temperature. Make sure that your baking tin is not placed directly in front of the air outlets in the rear wall of the cooking compartment. Check that the baking tin is in the correct position on the wire rack.
The cake on the baking tray is unevenly browned	Check the shelf height. Check the temperature. If you are baking on several levels, take out the baking trays at different times. When baking small items, make sure that they are the same size and thickness.
The cake is too dry	Set a slightly higher temperature and a slightly shorter baking time.
The cake is too moist in the centre	Set a slightly lower temperature. Note: Higher temperatures do not necessarily mean shorter baking times (cooked on the outside, but not on the inside). Select a longer baking time and allow the cake mixture to prove for longer. Add less liquid to the mixture.
With very moist cakes, e.g. fruit flans, a lot of steam is generated in the cooking compartment which condenses on the appliance door.	If you briefly and carefully open the appliance door (once or twice, or more often for longer baking times), you can let the steam out of the cooking compartment and considerably lessen the condensation.
The cake collapses when you take it out of the oven	Use less liquid for the mixture. Set a longer baking time or a slightly lower temperature.
The specified baking time is not correct	For small items, check the quantity on the baking tray. The items must not be touching each other.
Frozen products are not browned evenly after baking	Check whether the frozen product is unevenly browned before baking. This uneven browning will remain after the baking time.
Frozen products are not browned, not crispy or the specified time is not correct	Remove ice from frozen products before baking. Do not use frozen products that are heavily frosted
Saving energy	Only preheat the appliance when it is specified in the baking table that you should do so. Use dark baking tins as these absorb the heat better. Make use of the residual heat with longer baking times and switch the oven off 5 - 10 minutes before the end of the baking time.

Roasting

In this section, you will find information on

- roasting in general
- roasting without a lid
- roasting with a lid
- roasting meat, poultry and fish (roasting table)
- tips and tricks for roasting

⚠ There is a risk of injury if you use roasting dishes that are not heat-resistant!

Only use roasting dishes that are marked as being suitable for use in the oven.

Do not use shelf height 2 when roasting with  CircoTherm®. The air circulation would be impaired and this will have a negative effect on your roast.

Open roasting

For open roasting, a roasting dish without a lid is used.

While the meat is roasting, the liquid in the roasting dish will evaporate. Carefully pour in more hot liquid if required.

When you are roasting with  Top/bottom heat, turn the roast approximately half to two thirds of the way through the roasting time.

Roasting in the universal pan

Juices escape from the roasting meat and are collected in the universal pan. You can use these juices as the basis for a tasty gravy.

Deglaze the pan of the juices with hot water, stock, wine or similar. Bring to the boil, thicken with cornflour, season and pass through a sieve if necessary.

You can also cook side dishes (e.g. vegetables) at the same time as roasting meat in the universal pan.

For smaller joints, you can use a smaller roasting dish instead of the universal pan. Place this directly on the wire rack.

Roasting in the universal pan with wire insert

Place the wire insert in the universal pan with the lower area facing downwards and slide them in together at the same shelf position.

For fatty meat and poultry, add 1/8 to 1/4 litre of water to the universal pan, depending on the size and type of the joint.

Roasting in the universal pan with roasting sheet

The roasting sheet reduces dirt in the cooking compartment. Place the roasting sheet in the universal pan and slide them in together at the same shelf height.

Dripping fat and meat juices are caught in the universal pan.

Closed roasting

Roasting dishes with lids are used for this kind of roasting. This method is particularly suitable for pot roasts.

Place the joint in the roasting dish. Add water, wine, vinegar or a similar liquid for the braising liquid. Place the lid on the dish,

place the dish on the wire rack and slide it into the cooking compartment.

Roasting table

The roasting time and temperature depend on the size, height, type and quality of the item.

As a general rule: the larger the item, the lower the temperature and the longer the roasting time.



Coat lean meat with fat or oil as required and cover it with strips of bacon.

The information in the table is a guideline, and relates to items cooked without a lid. The values may vary depending on the type and quantity of the meat and on the roasting dish.

You should set the lower of the specified temperatures the first time. Lower temperatures will generally allow more even browning.

At the end of the roasting time, switch the oven off and leave the roast to rest for approximately 10 minutes in the cooking compartment with the door closed. The recommended rest time is not included in the given roasting times.



The information in the table is for food placed in a cold oven and for meat/fish taken directly from the refrigerator.

Item	CircoTherm® 			 Top/bottom heat	
	Shelf height	Temperature in °C	Roasting time in minutes	Shelf height	Temperature in °C
Meat loaf made from 500 g meat	1	170 - 180	60 - 70	1	200 - 210
Pork					
Smoked pork	1	160 - 170	60 - 70	1	190 - 210
Fillet, medium (400 g)	1	170 - 180	30 - 45	2	200 - 230
Roast with rind (1.5 kg)	1	160 - 170	100 - 130	1	200 - 220
Roast with rind (2.5 kg)	1	160 - 170	120 - 150	1	190 - 210
Joint, marbled, without rind, e.g. neck (1.5 kg)	1	160 - 170	120 - 150	1	190 - 210
Joint, marbled, without rind, e.g. neck (2.5 kg)	1	160 - 170	150 - 180	1	180 - 200
Roast, lean (1 kg)	1	170 - 180	70 - 90	1	180 - 200
Roast, lean (2 kg)	1	170 - 180	80 - 100	1	180 - 200
Beef					
Fillet, medium (1 kg)	1	180 - 190	45 - 65	1	200 - 220
Sirloin, medium rare (1.5 kg)	1	180 - 190	30 - 45	1	200 - 220
Pot roast (1.5 kg)**	1	170 - 180	120 - 150	1	200 - 220
Pot roast (2.5 kg)**	1	170 - 180	150 - 180	1	190 - 210
Veal					
Joint/breast of veal (1.5 kg)	1	160 - 170	90 - 120	1	180 - 200
Knuckle	1	160 - 170	100 - 130	1	190 - 210
Lamb					
Leg, boned	1	180 - 190	70 - 110	1	200 - 220
Loin on the bone	1	180 - 190*	40 - 50	1	200 - 220*
Loin, boned	1	180 - 190*	30 - 40	1	200 - 220*
Poultry					
Chicken, whole (1 kg)	1	170 - 180	60 - 70	1	200 - 220
Duck, whole (2 - 3 kg)	1	150 - 160	90 - 120	1	190 - 210
Goose, whole (3 - 4 kg)	1	150 - 160	130 - 180	1	180 - 200

* Preheat oven

** Roast pot roasts in ovenware with a lid

*** Use shelf height 1 for tall items

Item	CircoTherm® 			 Top/bottom heat	
	Shelf height	Temperature in °C	Roasting time in minutes	Shelf height	Temperature in °C
Game					
Joint/leg of roe venison, boned (1.5 kg)	1	160 - 170	90 - 120	1	190 - 210
Wild boar joint (1.5 kg)	1	160 - 170	100 - 120	1	190 - 210
Joint of venison (1.5 kg)	1	160 - 170	100 - 120	1	190 - 210
Rabbit	1	160 - 170	70 - 80	1	180 - 200
Fish					
Fish, whole (300 g)	1	160 - 170	20 - 30	1	190 - 210
Fish, whole (700 g)	1	160 - 170	30 - 40	1	180 - 200

* Preheat oven

** Roast pot roasts in ovenware with a lid

*** Use shelf height 1 for tall items

Tips and tricks

Crust too thick and/or roast too dry	Reduce the temperature or shorten the roasting time. Check the shelf height.
Crust too thin	Increase the temperature or switch on the grill briefly at the end of the roasting time.
The meat is not cooked right through	Remove any accessories that are not required from the cooking compartment. Increase the roasting time. Check the core temperature of the joint using a meat thermometer.
Steam in the cooking compartment is condensing on the appliance door	The steam dries during the course of the cooking. If there is an excessive volume of steam, you can carefully open the door briefly to dissipate the steam more quickly.

Grilling

In this section, you will find information on

- Grilling in general
- Circo-roasting 
- Radiant grilling (Full-surface  and Centre-area grill 

Caution!

Material damage due to effect of heat: The temperature generated in the cooking compartment is very high. Keep the appliance door closed when using the grill. Never grill with the appliance door open.

Notes

- It is preferable to use the universal pan with wire insert for grilling
- Place the wire insert in the universal pan and slide the two in together at the shelf position specified in the grilling table
- Always place the food to be grilled in the centre of the wire rack
- If you are grilling more than one piece of meat, make sure that they are the same sort of meat and that they are of similar thickness and weight.
- Use the wire rack for particularly large quantities. Slide in the wire rack at the shelf position specified in the grilling table. To prevent the cooking compartment from becoming dirty, slide in the universal pan one level lower.

Circo-roasting

The  Circo-roasting operating mode is ideal for poultry or meat (e.g. roast pork with crackling) that is to be crispy.

Turn large items of food after approximately half to two-thirds of the grilling time.

Pierce duck and goose skin under the wings and legs to allow the fat to escape.

Depending on the type of food you are cooking, the cooking compartment may become very dirty when you cook food using Circo-roasting. You should therefore clean the cooking compartment after every use so that the dirt does not bake on.

The details given in the table are guidelines and apply to the enamelled universal pan with wire insert. The values may vary depending on the type and amount of food to be grilled.

You should set the lower of the specified temperatures the first time. Lower temperatures will generally provide more even browning.

At the end of the cooking time, switch the grill off and leave the food to stand for approximately 10 minutes in the cooking compartment with the door closed. The recommended standing time is not included in the grilling times specified.

The values are for food placed in a cold oven and for meat taken directly from the refrigerator.

Grilled food	Shelf height	Temperature in °C	Grilling time in minutes
Sirloin, medium (1.5 kg)	1	210 - 230	40 - 60
Leg of lamb, boned, medium	1	190 - 210	120 - 150
Pork			
Joint of pork with rind	1	170 - 190	130 - 140
Pork knuckle	1	180 - 200	150 - 180
Poultry (unstuffed)			
Chicken halves (1 or 2 halves)	1	200 - 220	40 - 50
Chicken, whole (1 or 2 chickens)	1	200 - 220	50 - 70
Duck, whole (2 - 3 kg)	1	180 - 200	90 - 120
Duck breast	2	230 - 250	20 - 30
Goose, whole (3 - 4 kg)	1	150 - 170	140 - 160
Goose breast	1	210 - 230	30 - 40
Goose leg	2	200 - 220	40 - 50

Radiant grilling

For grilling large quantities of flat items, use the Full-surface grill.

For grilling small quantities of flat items, use the Centre-area grill. Place the food to be grilled in the centre of the wire rack. You will save energy by using the centre-area grill.

Brush the items to be grilled with a little oil according to taste.

Turn the items after half to two-thirds of the grilling time.

You can influence the grilling result by changing the position of the wire rack.

Wire rack position Application



Place the wire insert in the universal pan with the lower area facing downwards: Suitable for grill items that should be predominantly well-done



Place the wire insert in the universal pan with the lower area facing downwards: Suitable for grill items that should be cooked predominantly rare to medium-rare

Note: Always use the universal pan in the standard position (not the other way up).



Full-surface grill table

The information in the table contains only guide values. The values may vary depending on the type and amount of food to be grilled. They are for food placed in a cold oven and for meat taken directly from the refrigerator.

Grilled food	Shelf height	Temperature in °C	Grilling time in minutes	Notes
Toast with topping	2	220	10 - 15	The shelf height should be adapted to the height of the topping
Vegetables	3	<i>int</i>	15 - 20	
Sausages	3	250	10 - 14	Prick skins
Pork				
Fillet steaks, medium-sized (3 cm thick)	3	<i>int</i>	12 - 15	The cooking result can be influenced by the position of the wire rack
Steak, well-done (2 cm thick)	3	<i>int</i>	15 - 20	
Beef				
Fillet steaks (3 - 4 cm thick)	3	<i>int</i>	15 - 20	The grilling time can be increased or shortened depending on how well-done the meat should be
Tournedos	3	<i>int</i>	12 - 15	
Lamb				
Fillet	3	<i>int</i>	8 - 12	The grilling time can be increased or shortened depending on how well-done the meat should be
Chops	3	<i>int</i>	10 - 15	
Poultry				
Chicken halves	2	250	45 - 50	
Chicken legs	2	250	25 - 30	Piercing the skin will prevent blisters from forming during grilling
Small chicken portions	2	250	25 - 30	

Grilled food	Shelf height	Temperature in °C	Grilling time in minutes	Notes
Fish				
Steaks	3	220	15 - 20	The pieces should be of equal thickness
Chops	3	220	15 - 20	
Whole fish	2	220	20 - 25	

Centre-area grill table

The information in the table contains only guide values. The values may vary depending on the type and amount of food to be grilled. They are for food placed in a cold oven and for meat taken directly from the refrigerator.

Grilled food	Shelf height	Temperature in °C	Grilling time in minutes	Notes
Toast with topping	2	220	12 - 18	The shelf height should be adapted to the height of the topping
Vegetables	3	220	15 - 20	
Sausages	3	250	12 - 16	Prick skins

Poultry

Chicken legs	2	250	35 - 45	Piercing the skin will prevent blisters from forming during grilling
Small chicken portions	2	250	30 - 40	

Fish				
Steaks	3	230	15 - 20	The pieces should be of equal thickness
Chops	3	230	15 - 20	
Whole fish	2	230	20 - 25	

Steam cooking

The  Steam cooking operating mode can only be used in conjunction with the Mega System steamer (available as a special accessory from specialist retailers).

Only switch Steam cooking on when the cooking compartment has cooled down completely (room temperature).

If "Not possible" appears on the text display when you switch on the Steam cooking operating mode and **H** and  appear alternately in the temperature display, the cooking compartment has not cooled down completely.

Wait until the cooking compartment has cooled down and switch Steam cooking on again. The Steam cooking process is controlled automatically.

Notes

- Only use the Steam cooking operating mode for steaming.
- Only use the Mega System steamer for steaming.
- Do not use Steam cooking together with the preselection mode clock function.
- You will find further useful information in the instruction manual included with the Mega System steamer.

Dough proving

In this section, you will find information on

- Dough proving 
- preparing yeast dough and yoghurt

Only switch on Dough proving once the cooking compartment has completely cooled down (to room temperature).

If "Not possible" appears in the text display when the Dough proving setting is switched on and **H** or **h** and  appear alternately in the temperature display, the cooking compartment has not cooled down completely.

Wait until the cooking compartment has cooled down and switch Dough proving on again.

Do not use Dough proving together with the Preselection mode clock function.

Yeast dough

Caution!

- Damage to the enamel surfaces from pouring cold water into the hot cooking compartment. Do not pour cold water into the hot cooking compartment.
 - Distilled water will damage the surfaces in the cooking compartment. Use tap water only.
1. Pour 200 ml water in the base trough of the cooking compartment.
 2. Place the dish in the centre of the wire rack and slide in at shelf height 1.
 3. Close the appliance door and switch on  Dough proving. The proving process is controlled automatically. The temperature setting is fixed.

4. Remove any remaining water from the cooking compartment after the proving process is complete.

5. Loosen any limescale with a little vinegar and wipe with clean water.

The information in the table contains only guide values.

You can find information on how to proceed, further instructions and recipes in the accompanying cookbook.

Yeast dough	Amount of flour in grams	Proving time in minutes
Light dough (e.g. pizza dough, plaited loaf)	300 - 500	25 - 30
	750	30 - 35
Heavy, fat-rich dough (e.g. stollen, panettone)	500	40 - 60
	750	60 - 80
Light bread dough	1000	30 - 40
Heavy bread dough	1000	50 - 70

Yoghurt

1. Remove accessories and hook-in racks, telescopic shelves or separate fitting systems.

2. Heat 1 litre of long-life milk (3.5 % fat) or fresh pasteurised milk to 40 °C

or

Bring 1 litre of fresh milk to the boil once and allow to cool down to 40 °C.

3. Add 150 g of set yoghurt to the warm milk, stir in and fill the jars or bowls evenly. Do not pour more than 200 ml into any single container.

4. Cover the filled containers with a suitable lid or cling film.

5. Distribute the containers over the entire cooking compartment floor, evenly spaced out.

6. Close the appliance door and switch on  Dough proving. The proving process is controlled automatically. The temperature setting is fixed.

7. After 8 hours, switch off  Dough proving and place the containers in the refrigerator for at least 15 hours.

Low-temperature cooking

In this section, you will find information on

■ Low-temperature cooking 

■ Tips and tricks

Low-temperature cooking is a method of cooking slowly at low temperatures, and is also known as slow cooking.

Low-temperature cooking is ideal for all prime cuts of meat (e.g. tender portions of beef, veal, pork, lamb and poultry) that are to be cooked medium/medium rare or "à point". The meat will remain succulent and tender.

Using Low-temperature cooking

Notes

■ Only use fresh, clean meat

■ The meat will always look pink on the inside after Low-temperature cooking. This does not mean that the cooking time was too short

■ Only use boned meat

■ Do not use defrosted meat

■ You can also use seasoned or marinated meat

■ Always use shelf height 1 for Low-temperature cooking

■ Do not cover the meat while it is cooking in the cooking compartment

■ Do not turn pieces of meat during the low-temperature cooking process

■ The size, thickness and type of meat will have a significant influence on the searing and low-temperature cooking times

■ The properties of the pan and the heat output of the hotplate can influence the searing time

■ Do not use the Low-temperature cooking mode together with the Preselection mode clock function

Only switch the Low-temperature cooking mode on when the cooking compartment has completely cooled down (room temperature).

If "Not possible" appears in the text display when the Low-temperature cooking mode is switched on and **H** or **h** and **III** appear alternately in the temperature display, the cooking compartment has not cooled down completely.

Wait until the cooking compartment has cooled down and switch Low-temperature cooking on again.

1. Place a glass or porcelain plate on a wire rack and insert at shelf height 1 to warm the plate.

2. Switch on  Low-temperature cooking.

"Please wait" appears in the text display during the heating up phase (15 - 20 minutes).

3. Remove fat and sinews from the meat.

4. Sear the meat on all sides to seal the meat and to create a roasted flavour.

5. When a signal sounds and "In operation" appears on the text display, place the meat on the glass or porcelain plate in the cooking compartment.

6. Take out the meat at the end of the cooking time and switch off the appliance.

Note: Meat cooked at a low temperature does not need to rest, and can easily be kept warm at a low temperature.

Table for Low-temperature cooking

The information in the table contains only guide values. The searing time is for searing in a hot pan with fat.

Place the duck breast in a cold pan and fry the skin side first. Following Low-temperature cooking, insert at shelf height 3 and grill at 250 °C for 3 - 5 minutes until crispy.

You can find information on how to proceed, further instructions and recipes in the accompanying cookbook.

	Searing in minutes	Low-temperature cooking in minutes
Pork		
Fillet, whole (approx. 500 g)	5 - 6	100 - 120
Loin (approx. 1 kg, 4 - 5 cm thick)	5 - 6	120 - 150
Medallions (5 cm thick)	3 - 4	45 - 60
Loin steaks (2 - 3 cm thick)	2 - 3	30 - 45

	Searing in minutes	Low-temperature cooking in minutes
Beef		
Fillet, whole (1.5 kg)	6 - 7	160 - 200
Sirloin (approx. 1.5 kg, 5 - 6 cm thick)	6 - 7	180 - 210
Centre-cut rump (6 - 7 cm thick)	6 - 7	240 - 300
Medallions (5 cm thick)	3 - 4	60 - 80
Rump steak (3 cm thick)	3 - 4	50 - 70
Steak-cut rump (3 cm thick)	3 - 4	50 - 70
Veal		
Fillet, whole (approx. 800 g)	4 - 5	150 - 180
Flank (approx. 2 kg, 8 - 9 cm thick)	6 - 7	300 - 350
Centre-cut rump (approx. 1.5 kg, 4 - 5 cm thick)	6 - 7	300 - 350
Medallions (4 cm thick)	3 - 4	70 - 90

	Searing in minutes	Low-temperature cooking in minutes
Lamb		
Loin, boned (approx. 200 g)	2 - 3	30 - 40
Leg, boned (approx. 1 kg), tied	6 - 7	240 - 300
Poultry		
Chicken breast (150 - 200 g)*	4 - 5	90 - 120
Duck breast (300 - 400 g)**	10 - 12	70 - 90
Turkey breast (1 kg)*	4 - 5	150 - 180
Turkey steaks (2 - 3 cm)*	3 - 4	40 - 60

* well-done



** see the note below

Tips and tricks

Meat cooked at a low temperature cools down too quickly	Serve on warmed plates with a very hot sauce
Keeping meat cooked at a low temperature warm	Switch on  Top/bottom heat and set the temperature to 60 °C. Small pieces of meat can be kept warm for up to 45 minutes and large pieces for up to 2 hours

Defrosting

In this section, you can read about

- how to defrost using  CircoTherm®
- how to use the  Defrost operating mode

Defrosting with CircoTherm®

Use  CircoTherm® to defrost and cook frozen products.

Notes

- Frozen products that have been defrosted (meat in particular) require shorter cooking times than fresh products
- The cooking time for frozen meat increases by the defrosting time
- Always defrost frozen poultry before cooking so that you can remove the giblets
- Cook frozen fish at the same temperatures as fresh fish
- You can place large quantities of ready made frozen vegetables in aluminium dishes in the cooking compartment at the same time
- Use shelf height 1 when defrosting on one level, and shelf heights 1 + 3 when using two levels
- Observe the instructions on the packaging when using frozen foods.

Frozen meals	Temperature in °C	Defrosting time in minutes
Raw frozen products/ foods	50	30 - 90
Bread/Bread rolls (750 - 1,500 g)	50	30 - 60
Dry, frozen tray bakes	60	45 - 60
Moist, frozen tray bakes	50	50 - 70

Defrost

Using defrost setting  you can defrost delicate pastries particularly well (e.g. cream cakes).

1. Switch on the  Defrost operating mode.
2. Defrost the frozen food for 25-45 minutes, depending on type and size.
3. Remove the frozen food from the cooking compartment and let it thaw for 30 - 45 minutes.

With small quantities (pieces), the defrosting time is shortened to 15-20 minutes and the extended defrosting time is shortened to 10-15 minutes.

Preserve

Risk of injury!

Preserving jars containing incorrectly preserved food can burst. Please observe the following instructions:

- Fruit and vegetables must be fresh and in good condition
- Only use clean and undamaged preserving jars
- The preserving jars must not touch each other in the cooking compartment during preserving

With  CircoTherm®, the cooking compartment can be used to preserve the contents of up to six ½, 1 or 1½ litre preserving jars at the same time.

Notes

- For each preserving process, only use preserving jars that are the same size and contain the same food.
- Pay attention to cleanliness when preparing and closing the preserving jars.
- Only use heat resistant rubber rings.
- You cannot preserve the following food in your appliance: the contents of tin cans, meat, fish or pie filling.

Preparing fruit

1. Wash fruit and, depending on the type, peel, remove the seeds and finely chop.
2. Fill the preserving jars with fruit up to approx. 2 cm below the rim.
3. Fill the preserving jars with hot, skimmed sugar solution (approx. ⅓ l for a one litre jar).

To one litre water:

- approx. 250 g sugar for sweet fruit
- approx. 500 g sugar for sour fruit

Preparing vegetables

1. Wash vegetables and depending on the type, clean and finely chop.
2. Fill the preserving jars with vegetables up to approx. 2 cm below the rim.
3. Fill the preserving jars immediately with hot, boiled water.

Closing the preserving jars

1. Wipe the rims of the preserving jars with a clean, damp cloth.
2. Put a wet rubber ring and lid in place and close the jars with the clips.

Starting the preserving process

1. Insert the universal pan at shelf height 1.
2. Position the preserving jars in a triangle without them touching each other.



3. Pour ½ litre of hot water (approx. 80 °C) into the universal pan.

4. Set  CircoTherm® at 160 °C.

- Preserving jars containing ½ or 1 litre will start to bubble after approx. 50 minutes
- Preserving jars containing 1½ litres will start to bubble after approx. 60 minutes

Ending the preserving process

For fruit, gherkins and tomato purée:

1. Turn off the appliance, once all preserving jars are bubbling.
2. Allow the preserving jars to stand in the closed cooking compartment for several minutes longer.
 - Raspberries, strawberries, cherries or gherkins: approx. 5 - 10 minutes
 - Other fruit: approx. 10 - 15 minutes
 - Tomato or apple purée: approx. 15 - 20 minutes

For vegetables:

1. Reduce the temperature to 100 °C once all the preserving jars are bubbling. Allow the preserving jars to continue bubbling for approx. 60 minutes in the closed cooking compartment.
2. Switch off the appliance.
3. Allow the preserving jars to stand in the closed cooking compartment for approx. 15 - 30 minutes longer.

Removing the preserving jars

1. Place the preserving jars on a clean cloth, cover and protect from draughts.
2. Remove clips only when the jars are cold.

Cleaning and care

In this section, you will find information on

- cleaning and care of your appliance
- Cleaning agents and aids
- self-cleaning surfaces in the cooking compartment
- EasyClean® cleaning aid

Risk of short circuit!

Do not use high-pressure cleaners or steam jet cleaners to clean your appliance.

Caution!

Surface damage due to incorrect cleaning: Do not use any

- harsh or abrasive cleaning agents
- cleaning agents that contain alcohol
- abrasive cleaning aids such as steel wool or scourers.

Observe the specifications in the tables.

Note: Highly recommended cleaning and care products can be purchased through our after-sales service. Observe the manufacturer's instructions.

Cleaning the appliance exterior

Appliance part/surface	Cleaning agent/aid
Stainless steel surfaces	Apply commercially available washing-up liquid with a soft, damp cloth or chamois; dry with a soft cloth. Use cleaners for matted stainless steel if very dirty.
Painted surfaces	Apply commercially available washing-up liquid with a soft, damp cloth or chamois; dry with a soft cloth.
Control panel	Apply commercially available washing-up liquid with a soft, damp cloth or chamois; dry with a soft cloth. Do not use glass cleaners or glass scrapers.
Door panels	Use a commercially available glass cleaner or washing-up liquid with a soft, damp cloth or chamois; dry with a soft cloth. The inner door panel on the appliance door has a coating which reduces the temperature and reflects the heat. The view through the appliance door is not impaired by this. When the appliance door is open, this coating can have the effect of a light-coloured film. This is part of the design and is not due to any quality defect.

Cleaning the cooking compartment

Caution!

Risk of damaging the surface. Do not clean the appliance while still warm, even if using oven cleaners specially intended for this purpose.

Notes

- Enamel is baked on at very high temperatures during manufacture. This can cause some slight colour variations. This is normal and does not affect operation.
- The edges of thin trays cannot be completely enamelled. As a result, these edges can be rough. Anti-corrosion protection is still guaranteed, however.

Appliance part	Cleaning agent/aid
Enamel surfaces (smooth surface)	To facilitate cleaning, you can switch on the interior lighting and detach the appliance door if necessary. Apply commercially available washing-up liquid or a vinegar solution with a soft, damp cloth or chamois; dry with a soft cloth. Loosen baked-on food residues with a damp cloth and detergent. We recommend using oven cleaner if the oven is very dirty. When cleaning using an oven cleaner, check the manufacturer's instructions. Leave the cooking compartment open to dry after cleaning.
Self-cleaning surfaces (rough surface)	Please see the notes in section: Self-cleaning surfaces
Door seal	Hot soapy water
Hook-in rack/telescopic shelf	Hot soapy water
Accessories	Soak in hot soapy water, clean with a brush and sponge or wash in the dishwasher.

Keeping the appliance clean

To avoid getting the cooking compartment dirty,

- clean the cooking compartment after each use, as dirt will bake on the next time it is heated up, and this can only be removed with difficulty
- always remove flecks of limescale, grease, starch and albumin (e.g. egg white) immediately
- use  CircoTherm® whenever possible. This operating mode creates less dirt
- Use the universal pan to bake very moist cakes
- use suitable ovenware when roasting (e.g. roasting dish) or a roasting sheet (see section: Accessories)

Self-cleaning surface

The back wall of the cooking compartment is coated with self-cleaning enamel. This coating absorbs and disintegrates splashes from baking and roasting while the oven is in operation.

Large splashes only disappear after the oven has been used several times.

Discolouration on the rear wall does not affect the self-cleaning function.

Caution!

Damage to surfaces on self-cleaning areas due to applying oven cleaner. Never clean the self-cleaning surfaces with oven cleaner.

If oven cleaner accidentally gets onto self-cleaning surfaces, remove it immediately with a sponge and plenty of water.

Caution!

Damage to surfaces on self-cleaning areas due to the use of abrasive and acidic cleaning agents and aids.

Do not use cleaning agents containing abrasive substances or acids.

Do not use abrasive cleaning aids such as steel wool or scourers.

EasyClean®

Your appliance comes with an  EasyClean® function to make cleaning the cooking compartment easier. An automatically controlled vaporisation of soapy water loosens residues and makes it easier to remove them afterwards.

In the case of persistent dirt, you can

- allow the soapy water to penetrate for a while before switching on EasyClean
- rub detergent onto the dirty surfaces before switching on the cleaning aid
- repeat the EasyClean® function once the cooking compartment has cooled

Preparation and switching on

EasyClean® only starts when the cooking compartment is cool.

Risk of scalding and surface damage!

Never pour water into the cooking compartment when it is hot. Water vapour will be created and the enamel may be damaged because of the change in temperature.

1. Remove the accessories from the cooking compartment.
2. Carefully pour 0.4 litres of water (not distilled water) with some detergent into the base trough of the cooking compartment (Fig. A).
3. Close the appliance door.
4. Switch on EasyClean®.

"EasyClean in operation" appears in the text display and **ECS** in the temperature display.

If, after EasyClean is switched on, "Not possible" appears in the text display and **h** or **H** and **ECS** appear alternately in the temperature display, the cooking compartment has not completely cooled down.

Wait until the cooking compartment has cooled down and switch EasyClean® on again.

Once EasyClean® has finished, the cooking compartment light switches on and "EasyClean complete" appears in the text display. A signal sounds.

5. Press the clock function button to exit the clock function.

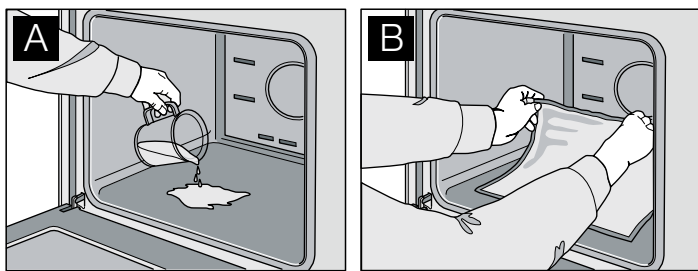

Cleaning up and switching off

Do not leave the remaining water in the cooking compartment for a long time (e.g. overnight).

1. Open the appliance door and remove the remaining water with an absorbent sponge cloth (Fig. B).
2. Clean the cooking compartment with a sponge cloth, a soft brush or a plastic saucepan scrubber.

Note: You can remove any remaining, persistent residue with a glass scraper for glass ceramic.

3. Remove limescale with a cloth soaked in vinegar, then wipe with clean water and rub dry with a soft cloth. Remember to dry under the door seal.

4. Turn the operating mode selector back to the **o** position.
5. After cleaning, leave the appliance door ajar in the stop position (approx. 30°) for approx. 1 hour to allow the enamel surfaces in the cooking compartment to dry thoroughly.

Rapid drying

1. After cleaning, leave the appliance door ajar in the stop position (approx. 30°).
2. Set  CircoTherm® at 50 °C.
3. After 5 minutes, switch off the appliance and close the appliance door.

Removing and fitting the appliance door

You can remove the appliance door to clean it more thoroughly.

Risk of injury!

The hinges of the appliance door may snap shut with great force. Always open the hinge locking lever fully when removing the appliance door and close it fully after refitting. Do not reach into the hinge.

Risk of injury!

If the appliance door has only been unhinged on one side, do not reach into the hinge. The hinge can snap back with great force. Call the after-sales service.

Removing the appliance door

1. Open the appliance door fully.
2. Open the locking levers on the left and right-hand side fully.

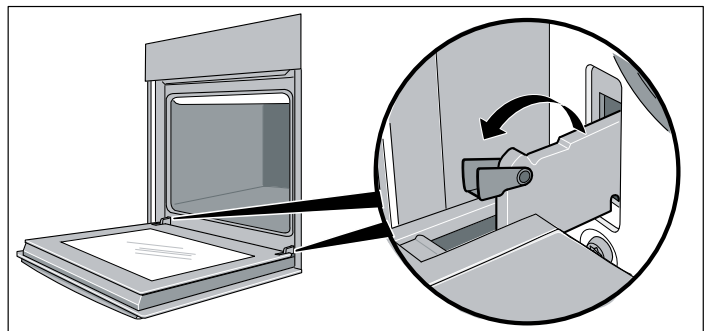

The hinges are secured and cannot snap closed.

3. Close the appliance door until resistance becomes noticeable (figure A)
4. With both hands, grip the door on the left and right-hand side, close the door a little more and pull it out (figure B).

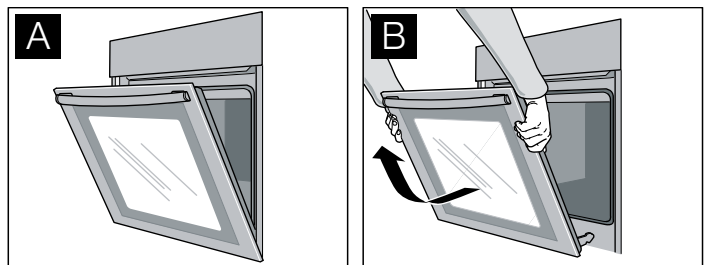

Fitting the appliance door

1. Insert the hinges in the left and right-hand holders (figure C).
The notch on both hinges must engage.
2. Open the appliance door fully.
3. Close the locking levers on the left and right-hand side fully (figure D).

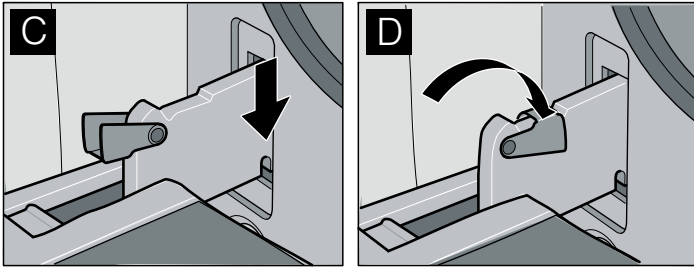

The appliance door is secured and can no longer be removed.

4. Close the appliance door.

Cleaning the door panels

To facilitate cleaning, you can remove the door panels from the appliance door.

⚠ Risk of injury!

The components inside the appliance door may have sharp edges. Take care not to cut yourself. Wear protective gloves.

⚠ Risk of injury!

The appliance must not be used again until the door panels and appliance door have been correctly fitted.

Removing the door panel

Note: Before removing, make a note of which way round the door panel is fitted, so that it is not refitted the wrong way round.

1. Unhook the appliance door and lay it on a soft, clean surface with the front side facing downwards (see section: Removing and installing the appliance door) (fig. A).
2. Press in the tabs on the left and right using your fingers (fig. A).
3. Carefully lift the door panel slightly and remove it in the direction of the hinges (fig B).

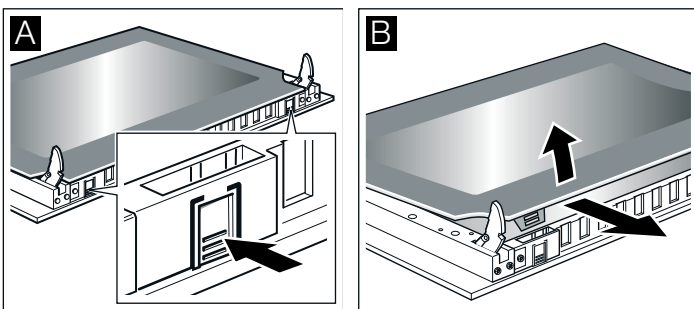

Removing the intermediate panel

Note: Before removing, make a note of the position in which the intermediate panel is fitted, so that you do not refit it the wrong way round later.

1. Remove the seal. Pull the seal outwards and remove it upwards (fig. C).

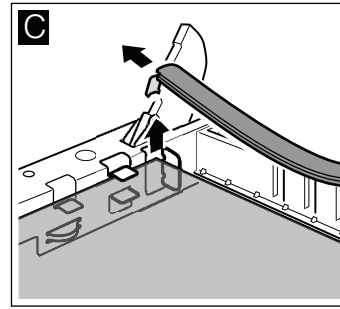

2. Release and remove the retainer (fig. D).
3. Lift the intermediate panel slightly and take it out (fig. E).

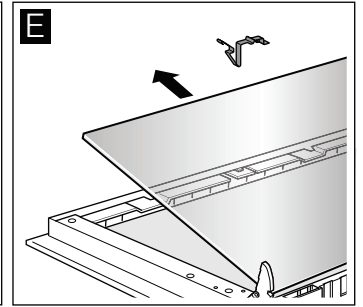
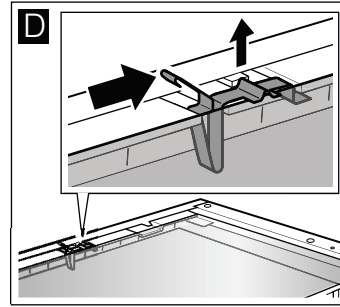

Cleaning

Clean the door panels with glass cleaner and a soft cloth.

Caution!

Do not use any sharp or abrasive medium or a glass scraper. The glass could be damaged.

Fitting the intermediate panel

Note: During installation, make sure that the lettering "top right" is upside down at the bottom left.

1. Insert the intermediate panel towards the back as far as it will go (fig. A).
2. Hook in the seal on both sides (fig. B).

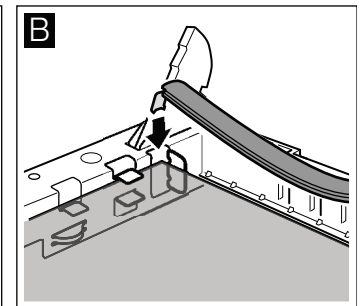
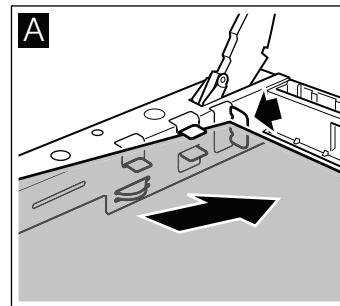

3. Insert the retainer (fig C).
4. Press down on the retainer until it locks into position (fig. D).

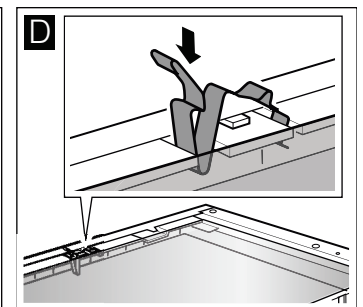
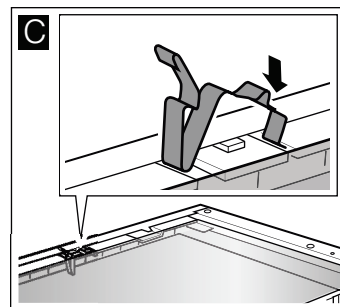

Fitting the door panel

1. Insert the door panel into the retainers at an angle towards the rear (fig. E).
2. Press down door panel near the hinges until it locks into place (fig. F).

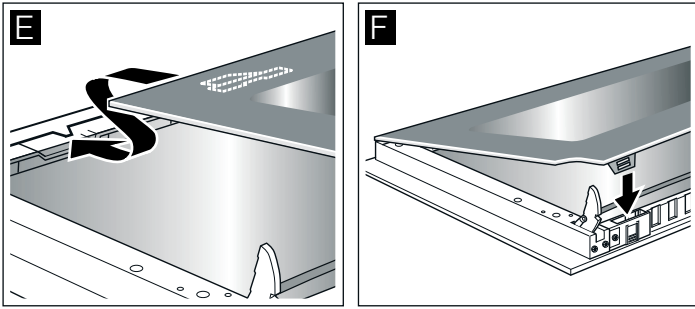

3. Refit the appliance door.

Cleaning the cooking compartment ceiling

The grill element can be folded down to allow quick and easy cleaning of the cooking compartment ceiling.

⚠ Risk of burning due to hot components in the cooking compartment!

Wait until the cooking compartment has cooled down.

1. Pull the grill element retaining bracket towards the front and push it upwards until you hear the grill element disengage (figure A).
2. Hold the grill element and fold it downwards (figure B).

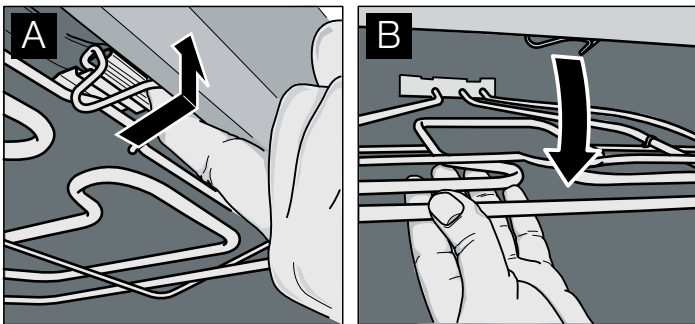

3. Clean the cooking compartment ceiling.
4. Pull the retaining bracket towards the front and keep it pushed upwards.
5. Fold the grill element upwards, until it clicks into place.

Cleaning the hook-in racks

You can remove the hook-in racks for easier cleaning.

⚠ Risk of burning due to hot components in the cooking compartment!

Wait until the cooking compartment has cooled down.

1. Pull out and detach the hook-in rack at the front (Fig. A).
2. Clean the hook-in rack with washing-up liquid and a sponge or brush.
3. After cleaning, refit the hook-in rack in the reverse order (Fig. B).

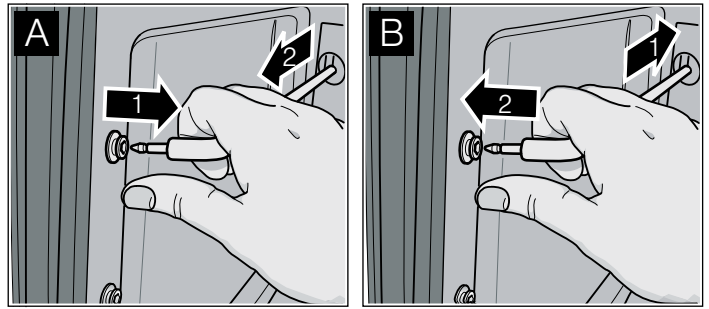

Cleaning the telescopic shelves

You can unhook the telescopic shelves for easier cleaning.

⚠ Risk of burning due to hot components in the cooking compartment!

Wait until the cooking compartment has cooled down.

Removing the telescopic shelves

1. Hold the flat spring (Fig. A).
2. Move the telescopic shelf upwards at the front and unhook it to the side.
3. Pull out the telescopic shelf at the back.

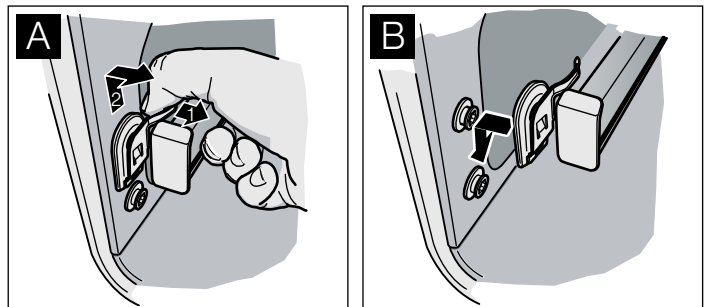

Cleaning the telescopic shelves

Clean the telescopic shelves with washing-up liquid and a sponge or brush.

Hooking in the telescopic shelves

1. Insert the telescopic shelf at the rear as far as it will go.
2. Insert the telescopic shelf at the front from the top and push it down until it engages (Fig. B).
3. Push telescopic shelves to the limit stop and close appliance door.

Faults and repairs

It is not always necessary to call the after-sales service. Sometimes, you can find a remedy yourself. You will find some tips for troubleshooting in the following table.

⚠ Risk of electric shock!

- Work on the appliance electronics may only be performed by a specialist.
- Always disconnect the appliance from the power supply when work is carried out on the electronics. Switch off the circuit breaker or remove the fuse from your household fuse box.

Problem	Possible cause	Remedial action
Electrical operation is faulty (e.g. indicator lamps no longer light up)	Fuse defective	Check fuses in the fuse box and replace if necessary
Liquid or runny dough runs to one side	Appliance not installed level	Check the appliance installation (see the Installation instructions)
0:00 flashes in the clock display	There was a power cut	Press the ◀▶ clock function button, reset the clock (see section: Electronic clock)
0:00 flashes on the clock display, "rrr" appears on the temperature display	The power supply was interrupted while the appliance was in operation	Press the ◀▶ Time of day function button, reset the clock (see section: Electronic clock)
"E011" appears in the clock display.	Permanent assignment of a button	Cancel the permanent assignment of the button and press the ◀▶ clock function button
EXXX, e.g. E300, appears in the clock display	Internal fault in the appliance electronics	Press the ◀▶ clock function button. If the message does not go out, pull out the mains plug and plug it back in again after approx. 10 seconds
It is not possible to operate the appliance, "Appliance locked" appears on the text display, ∞ and -S- appear on the temperature display.	The appliance has been locked	Deactivate the lock (see section: Childproof lock)
It is not possible to operate the appliance, "Appliance permanently locked" appears on the text display, ∞ and SP appear on the temperature display.	The appliance has been automatically blocked	Deactivate the permanent lock (see section: Childproof lock)
The appliance does not heat up, the two dots flash on the clock display and 1800, for example, appears in the temperature display	A button combination was actuated	Switch off the appliance, press and hold the i info button for 3 seconds, then press and hold the ◀▶ clock function button for 4 seconds, then press and hold the i info button again for 3 seconds
Electronically controlled functions are malfunctioning	Energy surges (e.g. lightning strike)	Reset the function concerned
Once you have switched on an operating mode, H or h appears on the temperature display, and "Not possible" appears on the text display	The appliance has not cooled down fully	Wait until the appliance has cooled down, then switch on the operating mode again
The appliance has switched off automatically. "Safety cut-out" appears in the text display, 0:00 flashes in the temperature display	The appliance has switched off to protect itself from overheating	Turn the operating mode selector back to the 0 position
000 flashes in the temperature display	Appliance is not switched off.	Turn the operating mode selector back to the 0 position and lock it in place
Smoke is generated during roasting or grilling	Fat is burning on the grill element	Continue grilling or roasting until the fat on the grill element has burnt away
	Wire rack or universal pan inserted incorrectly	Check the shelf heights (see section: Roasting or grilling)
High levels of condensation are generated in the cooking compartment	Normal occurrence (e.g. when baking cakes with very moist toppings or roasting a large joint)	Open the appliance door briefly from time to time during operation
Enamelled accessories have matt, light-coloured marks	Normal occurrence caused by dripping meat or fruit juices	Not possible
Door panels are misted up	Normal occurrence caused by temperature differences	Heat the appliance up to 100 °C and then switch off again after 5 minutes

Replacing the oven light bulb

Replace faulty oven light bulbs.

You can obtain replacement light bulbs from customer service or specialist retailers: E14, 220 - 240 V, 40 W, heat resistant to 300 °C. Only use these oven light bulbs.

Risk of electric shock !

Disconnect the appliance from the power supply. Switch off the circuit breaker or remove the fuse from the household fuse box.

1. Place a tea towel in the cold cooking compartment to prevent damage.
2. Turn the glass cover anticlockwise and remove it.

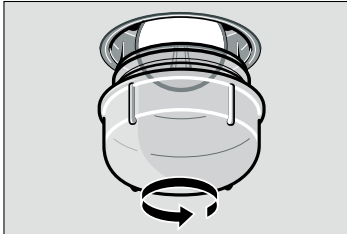

3. Replace the oven light bulb with a bulb of the same type.
4. Screw on the glass cover again.
5. Remove the tea towel and switch on the circuit breaker.

Note: If the glass cover cannot be unscrewed: use rubber gloves to turn it. You can order a special removal tool through the after-sales service (order no. 613634)

Changing the door seal

If the door seal is defective, it must be replaced. Replacement seals for your appliance can be obtained from the after-sales service.

The door seal is attached in four places (figure A). When replacing it, disconnect and attach the hooks at all four points (figure B).

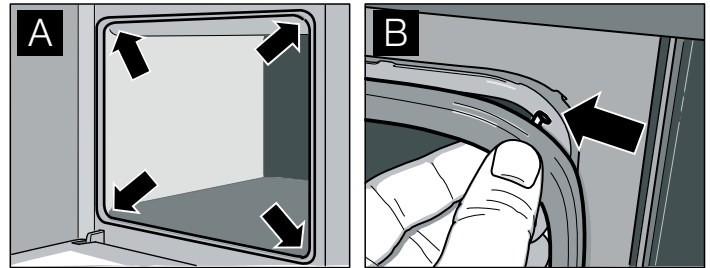

Check again to ensure that the seal is seated correctly in the corners in particular.

After-sales service

Our after-sales service is there for you if your appliance needs to be repaired. We will always find the right solution in order to avoid unnecessary visits from a service technician.

E number and FD number

When calling us, please give the product number (E no.) and the production number (FD no.) so that we can provide you with the correct advice. The rating plate containing these numbers can be found on the right-hand side of the oven door. You can make a note of the numbers of your appliance and the telephone number of the after-sales service in the space below to save time should it be required.

E no.

FD no.

After-sales service

Please note that there will be a fee for a visit by a service technician in the event of a malfunction, even during the warranty period.

Please find the contact data of all countries in the enclosed customer service list.

To book an engineer visit and product advice

GB 0844 8928989
Calls from a BT landline will be charged at up to 3 pence per minute. A call set-up fee of up to 6 pence may apply.

IE 01450 2655

Trust the expertise of the manufacturer, and rest assured that the repair will be carried out by trained service technicians using original spare parts for your domestic appliance.









Test dishes

These tables have been produced for test institutes to facilitate the inspection and testing of the various appliances.

Test dishes tested to standard EN 50304/EN 60350 (2009) and IEC 60350.



Please note the information in the tables about preheating. The table values do not include Rapid heat up.

Note: For baking, use the lower of the temperatures indicated first.

Baking	Shelf height	Operating mode	Temperature in °C	Baking time in minutes
Viennese whirls	2		150 - 160*	20 - 30
	1		140 - 150*	20 - 30
	1 + 3		140 - 150*	20 - 30
Small cakes (20 per tray)	2		160 - 170**	20 - 30
	1		150 - 160**	20 - 30
	1 + 3		150 - 160**	25 - 35
Hot water sponge cake	1		160 - 170*	25 - 35
	1		160 - 170*	25 - 35
Double crust apple pie (place baking tins next to one another)	1		170 - 180	60 - 70

* Preheat oven

** Preheat for 10 minutes

Grilling	Shelf position	Operating mode	Temperature in °C	Grilling time in minutes
Toast (universal pan + wire rack)	2 + 3		<i>int</i> *	1 - 2
Beef steaks, x 12 (universal pan + wire rack)	2 + 3		250	25 - 30**

* Preheat for 10 minutes

** Turn after $\frac{2}{3}$ of the time

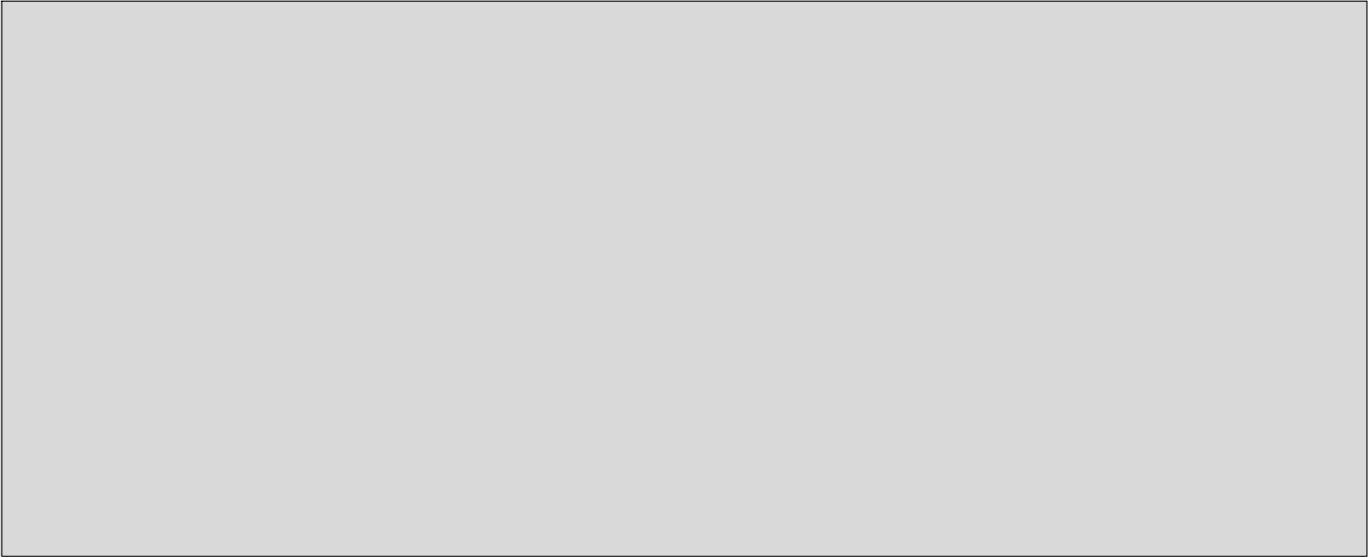

Constructa Neff
Vertriebs-GmbH
Carl-Wery-Straße 34
D-81739 München



9000724558

920613