

Extractor hood

[en] User manual and installation instructions

**I88WMM1Y7 I98WMM1Y7**  
**I98WMM1Y7B I88WMM1Y7B**



You can find additional information and explanations online.  
Scan the QR code on the title page.



# Table of contents

<b>INFORMATION FOR USE</b>		<b>10</b>	<b>Cleaning and servicing</b> .....	<b>10</b>	
<b>1</b>	<b>Safety</b> .....	<b>2</b>	<b>11</b>	<b>Troubleshooting</b> .....	<b>13</b>
<b>2</b>	<b>Avoiding material damage</b> .....	<b>4</b>	<b>12</b>	<b>Disposal</b> .....	<b>14</b>
<b>3</b>	<b>Environmental protection and saving energy</b> .....	<b>5</b>	<b>13</b>	<b>Customer Service</b> .....	<b>14</b>
<b>4</b>	<b>Operating modes</b> .....	<b>5</b>	<b>14</b>	<b>Accessories</b> .....	<b>15</b>
<b>5</b>	<b>Familiarising yourself with your appliance</b> .....	<b>6</b>	<b>15</b>	<b>Declaration of Conformity</b> .....	<b>15</b>
<b>6</b>	<b>Before using for the first time</b> .....	<b>7</b>	<b>16</b>	<b>Test information</b> .....	<b>16</b>
<b>7</b>	<b>Basic operation</b> .....	<b>7</b>	<b>17</b>	<b>INSTALLATION INSTRUCTIONS</b> .....	<b>16</b>
<b>8</b>	<b>Home Connect</b> .....	<b>9</b>	<b>17.3</b>	<b>Secure installation</b> .....	<b>17</b>
<b>9</b>	<b>Hob-based hood control</b> .....	<b>10</b>			

## 1 Safety

Observe the following safety instructions.

### 1.1 Definition of the signal words

This is where you can find explanations for the safety signal words used in this manual.

#### **WARNING**

This indicates that death or serious injuries may occur as a result of non-observance of this warning.

#### **ATTENTION**

This indicates that damage to the appliance or other material damage may occur as a result of non-compliance with this warning.

**Note:** This alerts you to important information.

### 1.2 General information

- Read this instruction manual carefully.
- Keep the instruction manual and the product information safe for future reference or for the next owner.
- Do not connect the appliance if it has been damaged in transit.

### 1.3 Intended use

This appliance is designed only to be built into kitchen units. Read the special installation instructions.

The appliance can only be used safely if it is correctly installed according to the safety in-

structions. The installer is responsible for ensuring that the appliance works perfectly at its installation location.

Only use this appliance:

- For extracting cooking vapour.
- in private households and in enclosed spaces in a domestic environment.
- up to an altitude of max. 4000 m above sea level.

Do not use the appliance:

- in combination with a gas hob.
- With an external timer.

### 1.4 Restriction on user group

This appliance may be used by children aged 8 or over and by people who have reduced physical, sensory or mental abilities or inadequate experience and/or knowledge, provided that they are supervised or have been instructed on how to use the appliance safely and have understood the resulting dangers.

Do not let children play with the appliance.

Children must not perform cleaning or user maintenance unless they are at least 15 years old and are being supervised.

Keep children under the age of 8 years away from the appliance and power cable.

## 1.5 Safe use

### ⚠ **WARNING – Risk of fire!**

Unsuitable appliance combinations may cause damage.

- ▶ Do not use the appliance in combination with gas hobs.
- Fatty deposits in the grease filters may catch fire.
- ▶ Never operate the appliance without a grease filter.
- ▶ Clean the grease filters regularly.
- ▶ Never work with naked flames close to the appliance (e.g. flambéing).
- ▶ Do not install the appliance near a solid fuel heating appliance (e.g. wood- or coal-burning) unless the heating appliance has a sealed, non-removable cover. There must be no flying sparks.

Hot oil and fat ignites very quickly.

- ▶ Always supervise hot oil and fat.
- ▶ Never extinguish burning oil or fat with water. Switch off the hotplate. Extinguish flames carefully using a lid, fire blanket or something similar and leave to cool down.

Fatty deposits in the grease filters may catch fire.

- ▶ Clean the grease filters regularly.

### ⚠ **WARNING – Risk of suffocation!**

Children may put packaging material over their heads or wrap themselves up in it and suffocate.

- ▶ Keep packaging material away from children.
- ▶ Do not let children play with packaging material.

Children may breathe in or swallow small parts, causing them to suffocate.

- ▶ Keep small parts away from children.
- ▶ Do not let children play with small parts.

### ⚠ **WARNING – Risk of poisoning!**

Risk of poisoning from flue gases being drawn back in. Room-air-dependent heat-producing appliances (e.g. gas, oil, wood or coal-operated heaters, continuous flow heaters or water heaters) obtain combustion air from the room in which they are installed and discharge the exhaust gases into the open through an exhaust gas system (e.g. a chimney). With the extractor hood switched on, air is extracted from the kitchen and the adjacent rooms.

Without an adequate supply of air, the air pressure falls below atmospheric pressure. Toxic gases from the chimney or the extraction shaft

are sucked back into the living space.

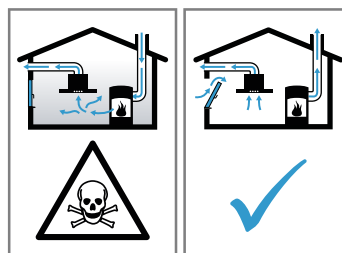

- ▶ Always ensure adequate fresh air in the room if the appliance is being operated in exhaust air mode at the same time as a room-air-dependent heat-producing appliance is being operated.
- ▶ It is only possible to safely operate the appliance if the pressure in the room in which the heating appliance is installed does not fall below 4 Pa (0.04 mbar). This can be achieved whenever the air needed for combustion is able to enter through openings that cannot be sealed, for example in doors, windows, incoming/exhaust air wall boxes or by other technical means. An incoming/exhaust air wall box alone is not sufficient to ensure compliance with the limit.
- ▶ In any case, consult your responsible chimney sweep. They are able to assess the house's entire ventilation setup and will suggest the suitable ventilation measures to you.

Using a gas cooking appliance leads to a build-up of heat, moisture and combustion products in the room where the appliance is installed.

- ▶ Switch on the extractor hood when using a gas cooking appliance.

### ⚠ **WARNING – Risk of burns!**

The accessible parts of the appliance become hot during operation.

- ▶ Never touch these hot parts.
- ▶ Keep children at a safe distance.

The appliance becomes hot during operation.

- ▶ Allow the appliance to cool down before cleaning.

### ⚠ **WARNING – Risk of injury!**

Components inside the appliance may have sharp edges.

- ▶ Carefully clean the appliance interior. Items placed on the appliance may fall off.
- ▶ Do not place any objects on the appliance.

Changes to the electrical or mechanical assembly are dangerous and may lead to malfunctions.

- ▶ Do not make any changes to the electrical or mechanical assembly.

The light emitted by LED lights is very dazzling, and can damage the eyes (risk group 1).

- ▶ Do not look directly into the switched-on LED lights for longer than 100 seconds.

If the appliance is operated by another person via the Home Connect app during cleaning, this increases the risk of injury.

- ▶ Before cleaning, disconnect the appliance from the Home Connect app.

→ *"Resetting the connection", Page 10*

Improper repairs are dangerous.

- ▶ Repairs to the appliance should only be carried out by trained specialist staff.

- ▶ If the appliance is defective, call Customer Service.

→ *"Customer Service", Page 14*

### ⚠ **WARNING – Danger: Magnetism!**

The removable profiles are magnetic and may affect electronic implants, e.g. pacemakers or insulin pumps.

- ▶ Persons with electronic implants must stay at least 10 cm away from the magnetic profiles.

### ⚠ **WARNING – Risk of electric shock!**

If the appliance or the power cord is damaged, this is dangerous.

- ▶ Never operate a damaged appliance.
- ▶ Never pull on the power cord to unplug the appliance. Always unplug the appliance at the mains.

- ▶ If the appliance or the power cord is damaged, immediately unplug the power cord or switch off the fuse in the fuse box.

- ▶ Call customer services. → *Page 14*

Improper repairs are dangerous.

- ▶ Repairs to the appliance should only be carried out by trained specialist staff.

- ▶ Only use genuine spare parts when repairing the appliance.

- ▶ If the power cord of this appliance is damaged, it must be replaced by trained specialist staff.

An ingress of moisture can cause an electric shock.

- ▶ Before cleaning, pull out the mains plug or switch off the fuse in the fuse box.

- ▶ Do not use steam- or high-pressure cleaners to clean the appliance.

Penetrating liquid may cause an electric shock.

- ▶ If a larger amount of liquid is flowing in the appliance, pull out the mains plug or switch off the fuse in the fuse box.

→ *"Malfunctions", Page 13*

Penetrating moisture may cause an electric shock.

- ▶ Do not use wet sponge cloths.

### ⚠ **WARNING – Risk of explosion!**

Highly caustic alkaline or highly acidic cleaning agents in conjunction with aluminium parts in the interior of the appliance may cause explosions.

- ▶ Never use highly caustic alkaline or highly acidic cleaning agents. In particular, do not use commercial or industrial cleaning agents in conjunction with aluminium parts, e.g. grease filter on extractor hoods.

---

## 2 Avoiding material damage

### **ATTENTION**

Condensate may cause corrosion damage.

- ▶ To prevent condensation from building up, switch on the appliance during cooking.

If moisture gets into the controls, this may result in damage.

- ▶ Never clean controls with a wet cloth.

Incorrect cleaning damages the surfaces.

- ▶ Follow the cleaning instructions.
- ▶ Do not use harsh or abrasive detergents.
- ▶ Clean stainless steel surfaces in the direction of the finish only.
- ▶ Never clean controls with stainless steel cleaners.

Condensation that flows back in may damage the appliance.

- ▶ The air extraction duct must be installed with a gradient of at least 1° from the appliance.

If you put incorrect stress on the design elements, they may break off.

- ▶ Do not pull design elements.

- ▶ Do not place objects on the design elements or hang objects from them.

There is a risk of surface damage if you do not peel off the protective film.

- ▶ Remove the protective film from all parts of the appliance before using for the first time.

Objects set down on the appliance may damage the appliance when it is extended.

- ▶ Do not place any objects on the appliance.

- ▶ With the remote control via the Home Connect app in particular, ensure that there are no objects on the appliance.

Painted surfaces are easily damaged.

- ▶ Follow the cleaning instructions.  
→ *"Cleaning the appliance", Page 11*
- ▶ Ensure that the painted surfaces are not scratched.

## 3 Environmental protection and saving energy

### 3.1 Disposing of packaging

The packaging materials are environmentally compatible and can be recycled.

- ▶ Sort the individual components by type and dispose of them separately.

### 3.2 Saving energy

If you follow these instructions, your appliance will use less power.

Adjust the fan speed to the amount of steam produced during cooking.

- ✓ The lower the fan speed, the less energy is consumed.
- ✓ Only use the intensive mode as required.

If cooking produces large amounts of steam, select a higher fan speed in good time.

- ✓ The odours are distributed around the room less.

Switch off the lighting if it is no longer required.

- ✓ When the lighting is switched off, it does not consume any energy.

Clean or replace the filters at regular intervals.

- ✓ The effectiveness of the filter is retained.

Put the cooking lid on.

- ✓ The cooking vapours and condensation are reduced.

Only use the additional functions if required.

- ✓ Switching off additional functions reduces power consumption.

You can find product information in accordance with (EU) 65/2014 and (EU) 66/2014 below the energy label and online on the product page for your appliance.

## 4 Operating modes

You can use your appliance in air extraction mode or circulating-air mode.

The saturation indicator must be adjusted to the selected operating mode and the filters used.

→ *"Setting the saturation indicator", Page 8*

### 4.1 Air extraction mode

The air which is drawn in is cleaned by the grease filters and conveyed to the exterior by a pipe system.



The air must not be discharged into a flue that is used for exhausting fumes from appliances burning gas or other fuels (not applicable to appliances that only discharge the air back into the room).

- If the exhaust air is to be conveyed into a non-functioning smoke or exhaust gas flue, you must obtain the consent of the heating engineer responsible.
- If the exhaust air is conveyed through the external wall, a telescopic duct should be used.

### 4.2 Air recirculation

The air which is drawn in is cleaned by the grease filters and an odour filter, and conveyed back into the room.



To bind odours in air recirculation mode, you must install an odour filter. The different options for operating the appliance in air circulation mode can be found in our catalogue. Alternatively, ask your dealer. The required accessories are available from specialist retailers, from our after-sales service or from the online shop.

→ *"Accessories", Page 15*

## 5 Familiarising yourself with your appliance

### 5.1 Overall view

You can find an overview of the parts of your appliance here.

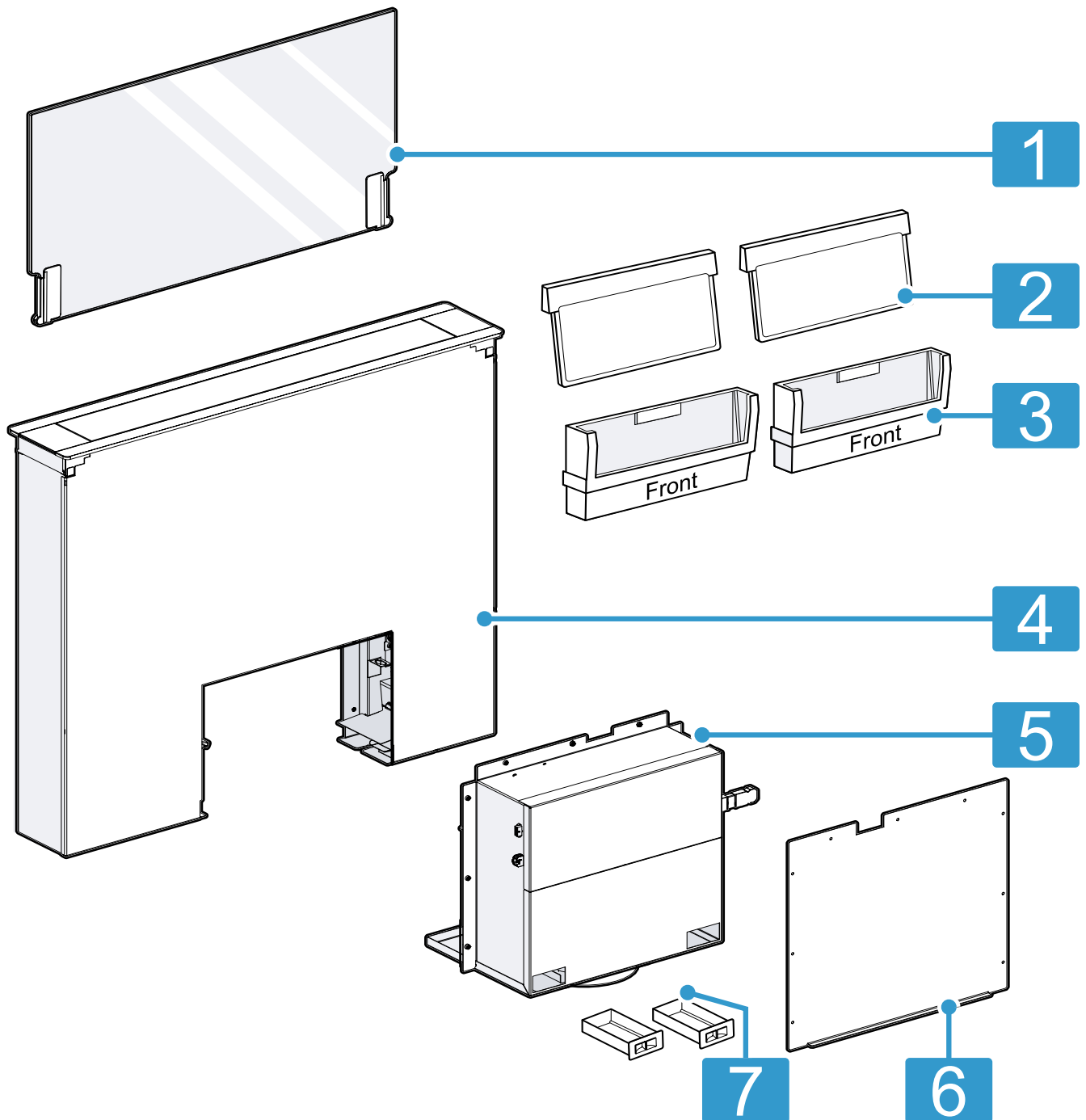

- 1 Glass plate
- 2 Grease filter
- 3 Filter cartridge
- 4 Appliance

- 5 Blower group
- 6 Cover plate
- 7 Drip tray

## 5.2 Controls

You can use the controls to configure all functions of your appliance and to obtain information about the operating status.

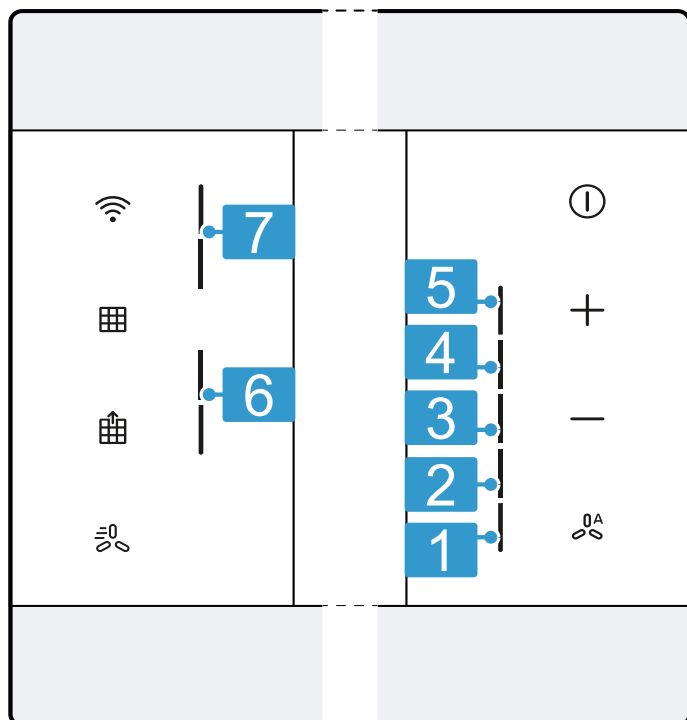

1	Fan setting 1
2	Fan setting 2
3	Fan setting 3
4	Intensive mode 1
5	Intensive mode 2
6	Odour filter saturation indicator <sup>1</sup>
7	Grease filter saturation indicator
ⓘ	Switching the appliance on or off
+	Increasing the fan setting
-	Decreasing the fan setting
OA	Switching automatic mode <sup>1</sup> on or off
Wi-Fi	Home Connect Establishing a connection
Grid	Reset the filter saturation indicator
House	Removing or inserting the grease filter/odour filter <sup>1</sup>
Fan	Switching Guided Air on or off

## 6 Before using for the first time

Configure the settings for initial start-up. Clean the appliance and accessories.

### 6.1 Setting an operating mode

Your appliance is set to air extraction mode by default.

**Note:** When using it in circulating-air mode, you require additional accessories.

- ▶ When using it in circulating-air mode, set the operating mode.  
→ "Setting the saturation indicator", Page 8

### 6.2 Optimal use of the appliance

The Guided Air function improves the extraction of the cooking vapour. In order to optimally use your appliance, switch this function on before using the appliance for the first time.

- ▶ Switch on Guided Air. → Page 9

## 7 Basic operation

### 7.1 Switching on the appliance

- ▶ Press ⓘ to switch on the appliance.
- ✓ The appliance starts at fan setting 2.
- ✓ The Ambient Light<sup>1</sup> automatically switches on.

### 7.2 Switching off the appliance

- ▶ Press ⓘ.
- ✓ The fan run-on starts at fan setting 1.
- ✓ The Ambient Light<sup>1</sup> remains switched on for approx. 10 minutes.
- ✓ The glass panel remains extended halfway.
- ✓ The appliance switches off automatically after approx. 10 minutes.
- ✓ If you have installed the appliance and have established the power connection, the glass pane moves downwards and appliance closes.

<sup>1</sup> Depending on the appliance specifications

## 7.3 Selecting a fan setting

- ▶ Press + or –.

## 7.4 Switching on intensive mode

If particularly strong odours or vapours develop, you can use intensive mode.

1. Press + repeatedly until LED 4 lights up in the LED display for intensive mode 1.
  2. Press + repeatedly until LED 5 lights up in the LED display for intensive mode 2.
- ✓ After approx. 6 minutes, the appliance automatically switches to fan setting 3.

## 7.5 Switching off intensive mode

- ▶ To select a fan setting of your choice, press –.

## 7.6 Switching on the fan run-on

During the fan run-on, the appliance continues to run for a short time and then switches off automatically.

**Note:** Further settings are available in the Home Connect app.

**Requirement:** The appliance is switched on.

- ▶ Press .
- ✓ The fan run-on starts at fan setting 1.
- ✓ The Ambient Light<sup>1</sup> remains switched on for approx. 10 minutes.
- ✓ The glass panel remains extended halfway.
- ✓ The appliance switches off automatically after approx. 10 minutes.
- ✓ If you have installed the appliance and have established the power connection, the glass pane moves downwards and appliance closes.

## 7.7 Intermittent ventilation

In order to regularly ventilate your kitchen, you can use the interval ventilation. With interval ventilation, the ventilation system switches on and off in the selected setting for the selected time.

**Note:** This function is only available in the Home Connect app.

If the interval ventilation is switched on, LED 1 flashes.

## 7.8 Switching on automatic mode<sup>1</sup>

The optimum fan setting is set automatically using a sensor.

- ▶ Press .
- ✓ The LED for the automatically set fan setting lights up in the LED display.

**Note:** In automatic mode, the Guided Air function is always switched on.

## 7.9 Switching off automatic mode<sup>1</sup>

- ▶ Press .
- ✓ The appliance starts at fan setting 2.
- ✓ The ventilation is automatically ended when the sensor detects no further change in the room air quality.
- ✓ Automatic mode runs for a maximum of four hours.

**Note:** Further settings are available in the Home Connect app.

## 7.10 Sensor sensitivity<sup>1</sup>



In automatic mode, a sensor in the appliance detects the intensity of the cooking odours and roasting odours. Depending on the setting of the sensor sensitivity, the optimum fan setting is automatically switched on. If the sensor control reacts too weakly or too strongly, you can change the setting for the sensor sensitivity.

- Factory setting: 3
- Lowest setting: 1
- Highest setting: 5

The corresponding LED lights up in the LED display.

## 7.11 Setting the sensor sensitivity<sup>1</sup>

**Requirement:** The appliance is switched on.

1. Press and hold  and  for approx. 3 seconds.
  2. Press + or – to change the setting.
  3. Press  to save the setting.  
Or wait approx. five seconds until the setting is saved automatically.
- ✓ A signal tone sounds as soon as the selected setting is saved.

## 7.12 Saturation indicator

If the grease filters or odour filters are saturated, corresponding symbols flash after the appliance is switched off.

**Note:** You can set the saturation indicator in the Home Connect app depending on the filter used.

Clean the saturated grease filters and, in doing so, observe the cleaning instructions in these instructions. Change the saturated odour filters and observe the instructions in the accompanying instructions. If odour filters can be regenerated, follow the instructions in the accompanying instructions.

## 7.13 Setting the saturation indicator

The saturation indicator must be adjusted depending on the filter used.

**Requirement:** The appliance is switched on.

1. Press and hold  and – for approx. 3 seconds.
  - ▶ To set circulating-air mode (Clean Air Standard circulating-air set or Clean Air Plus circulating-air set), press and hold +/- until LED 2 lights up in the LED display.
  - ▶ To set circulating-air mode (regenerable filter), press +/- until LED 3 lights up in the LED display.

<sup>1</sup> Depending on the appliance specifications

- ▶ To convert the electronic control back to operation without the air recirculation filter, press +/- until LED 1 lights up on the LED display.
- 2. Press  to save the setting.  
Or wait approx. five seconds until the setting is saved automatically.
- ✓ A signal tone sounds as soon as the selected setting is saved.

## 7.14 Resetting the saturation indicator

After cleaning the grease filter or after changing the odour filter, the saturation indicator can be reset.

### Requirements

- After switching off the appliance, the upper two LEDs for the grease filter's saturation indicator and/or the lower two LEDs for the odour filter's saturation indicator flash in the left hand control panel.
- A signal sounds repeatedly.
- ▶ Press .
- ✓ The saturation indicator is reset.

## 7.15 Switching on Ambient Light<sup>1</sup>

### Notes

- You can switch the Ambient Light on and off in the Home Connect app.
- Additional colours are available in the Home Connect app.

**Requirement:** Fan setting 1 is switched on.

- ▶ Press .
- ✓ The Ambient Light remains switched on.
- ✓ The ventilation system switches off.
- ✓ The glass panel remains at the top.

## 7.16 Switching on Guided Air

With the Guided Air function, the cooking vapour is routed in such a way that it can be optimally collected from the appliance and removed. The extraction of the cooking vapour is improved on front cooking zones in particular.

**Note:** This function is switched off by default.

- ▶ Press .

## 7.17 Switching off Guided Air

- ▶ Press .

# 8 Home Connect

This appliance is network-capable. Connecting your appliance to a mobile device lets you control its functions via the Home Connect app, adjust its basic settings and monitor its operating status.

The Home Connect services are not available in every country. The availability of the Home Connect function depends on the availability of the Home Connect services in your country. You can find information about this at: [www.home-connect.com](http://www.home-connect.com).

The Home Connect app guides you through the entire login process. Follow the instructions, noting the information in the Home Connect app.

### Notes

- Please note the safety precautions in this instruction manual and make sure that they are also observed when operating the appliance via the Home Connect app.  
→ "Safety", Page 2
- Operating the appliance on the appliance itself always takes priority. During this time it is not possible to operate the appliance using the Home Connect app.
- In networked standby mode, the appliance requires a maximum of 2 W.
- If you need your device's MAC address to connect to your home network, you can find this next to the rating plate. → Page 15

## 8.1 Setting up the Home Connect app

1. Install the Home Connect app on your mobile device.
2. Start the Home Connect app and set up access for Home Connect.  
The Home Connect app guides you through the entire login process.

## 8.2 Setting up Home Connect

### Requirements

- The appliance is switched off.
  - You have a mobile device with a current version of the iOS or Android operating system, e.g. a smartphone.
  - The appliance is receiving signals from the WLAN home network (Wi-Fi) at its installation location.
  - The mobile device and the appliance are within range of your home network's Wi-Fi signal.
1. Scan the following QR code.





You can install the Home Connect app and connect your appliance via the QR code.

2. Follow the instructions in the Home Connect app.

<sup>1</sup> Depending on the appliance specifications

### 8.3 Resetting the connection

- ▶ Reset the saved connections to the Wi-Fi and Home Connect by pressing and holding  and  for approx. three seconds.

### 8.4 Software update

Your appliance's software can be updated using the software update function, e.g. for the purposes of optimisation, troubleshooting or security updates.

To do this, you must be a registered Home Connect user, have installed the app on your mobile device and be connected to the Home Connect server.

As soon as a software update is available, you will be informed via the Home Connect app and will be able to start the software update via the app. Once the update has been successfully downloaded, you can start installing it via the Home Connect app if you are in your home network (Wi-Fi). The Home Connect app informs you once installation is successful.

The current software version can be found in the Home Connect app under the appliance information for the relevant home appliance.

#### Notes

- The software update consists of two steps.
  - The first step is the download.
  - The second step is the installation on your appliance.
- You can continue to use your appliance as normal while updates are downloading. Depending on your personal settings in the app, software updates can also be set to download automatically.
- Installation takes a few minutes. You cannot use your appliance during installation.
- We recommend that you install security updates as soon as possible.

### 8.5 Remote diagnostics

Customer Service can use Remote Diagnostics to access your appliance if you contact them, have your appliance connected to the Home Connect server and if Remote Diagnostics is available in the country in which you are using the appliance.

**Tip:** For further information and details about the availability of Remote Diagnostics in your country, please visit the service/support section of your local website: [www.home-connect.com](http://www.home-connect.com).

### 8.6 Data protection

Please see the information on data protection.

The first time your appliance is registered on a home network connected to the Internet, your appliance will transmit the following types of data to the Home Connect server (initial registration):

- Unique appliance identification (consisting of appliance codes as well as the MAC address of the Wi-Fi communication module installed).
- Security certificate of the Wi-Fi communication module (to ensure a secure data connection).
- The current software and hardware version of your appliance.
- Status of any previous reset to factory settings.

This initial registration prepares the Home Connect functions for use and is only required when you want to use the Home Connect functions for the first time.

**Note:** Please note that the Home Connect functions can only be utilised with the Home Connect app. Information on data protection can be retrieved in the Home Connect app.

---

## 9 Hob-based hood control

You can connect your appliance to a suitable hob and, in this way, control the functions of your appliance via the hob.

If the hob and the extractor hood are Home Connect-compatible, connect the appliances in the Home Connect app. To do this, connect the two appliances to Home Connect and follow the instructions in the app.

#### Notes

- Please note the safety precautions in the instruction manual for your appliance and ensure that they are

also observed when operating the appliance via the hob-based hood control.

- Operating your appliance always takes priority. It is not possible to use the hob-based hood control during this time.
- You can only connect to the extractor hood via the Home Connect app. Other connection routes are no longer supported.

---

## 10 Cleaning and servicing

To keep your appliance working efficiently for a long time, it is important to clean and maintain it carefully.

### 10.1 Cleaning products

You can obtain suitable cleaning products from after-sales service or the online shop.

#### ATTENTION

Unsuitable cleaning products may damage the surfaces of the appliance.

- ▶ Do not use harsh or abrasive detergents.
- ▶ Do not use cleaning products with a high alcohol content.
- ▶ Do not use hard scouring pads or cleaning sponges.

- ▶ Only use glass cleaners, glass scrapers or stainless steel care products if recommended in the cleaning instructions for the relevant part.
- ▶ Wash sponge cloths thoroughly before use.

## 10.2 Cleaning the appliance

Clean the appliance as specified. This will ensure that the different parts and surfaces of the appliance are not damaged by incorrect cleaning or unsuitable cleaning products.

### ⚠ **WARNING – Risk of explosion!**

Highly caustic alkaline or highly acidic cleaning agents in conjunction with aluminium parts in the interior of the appliance may cause explosions.

- ▶ Never use highly caustic alkaline or highly acidic cleaning agents. In particular, do not use commercial or industrial cleaning agents in conjunction with aluminium parts, e.g. grease filter on extractor hoods.

### ⚠ **WARNING – Risk of electric shock!**

An ingress of moisture can cause an electric shock.

- ▶ Before cleaning, pull out the mains plug or switch off the fuse in the fuse box.
- ▶ Do not use steam- or high-pressure cleaners to clean the appliance.

### ⚠ **WARNING – Risk of burns!**

The appliance becomes hot during operation.

- ▶ Allow the appliance to cool down before cleaning.

### ⚠ **WARNING – Risk of injury!**

Components inside the appliance may have sharp edges.

- ▶ Carefully clean the appliance interior.

If the appliance is operated by another person via the Home Connect app during cleaning, this increases the risk of injury.

- ▶ Before cleaning, disconnect the appliance from the Home Connect app.

→ "Resetting the connection", Page 10

1. Observe the information regarding the cleaning agents.
2. Clean as follows, depending on the surface:
  - ▶ Clean stainless steel surfaces in the direction of the finish using a sponge cloth and hot soapy water.
  - ▶ Clean painted surfaces using a damp sponge cloth and hot soapy water.
  - ▶ Clean aluminium using a soft cloth and glass cleaner.
  - ▶ Clean plastic using a soft cloth and glass cleaner.
  - ▶ Clean glass using a soft cloth and glass cleaner.
3. Dry with a soft cloth.
4. Apply a thin layer of the stainless steel cleaning product to stainless steel surfaces using a soft cloth. You can obtain stainless steel cleaning products from the after-sales service or the online shop.

## 10.3 Cleaning controls and lights

### ⚠ **WARNING – Risk of electric shock!**

Penetrating moisture may cause an electric shock.

- ▶ Do not use wet sponge cloths.

1. Observe the information regarding the cleaning agents.
2. Clean using a damp sponge cloth and hot soapy water.
3. Dry with a soft cloth.

## 10.4 Cleaning the glass panel

1. **Note:** The appliance frame is sensitive. Remove the glass pane vertically. Do not pull the glass pane over the appliance frame. The glass pane is heavy. Carefully remove the glass pane.

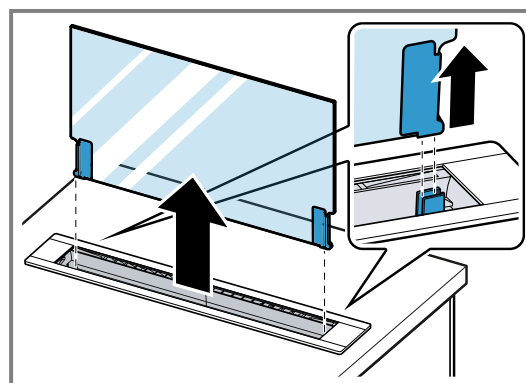

2. Observe the information regarding the cleaning agents.
3. Clean with a soft cloth and glass cleaner.
4. Carefully insert the glass pane as far as it will go into the guides.

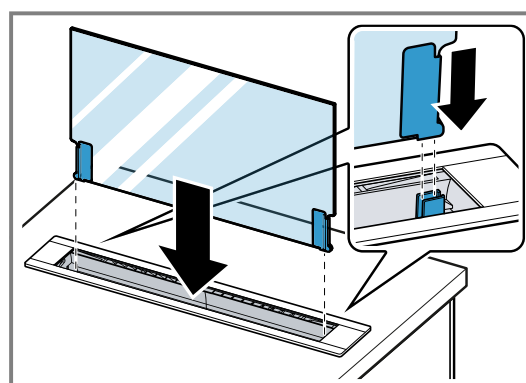

## 10.5 Cleaning the drip tray

When cooking or cleaning the appliance, liquid may get into the appliance. The drip trays are used to collect this liquid.

1. Remove the drip tray ① and empty it ②.

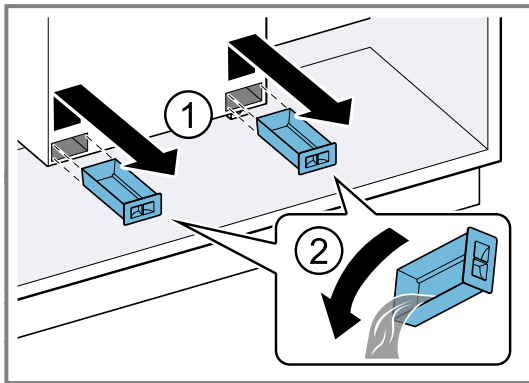

2. Observe the information regarding the cleaning agents.
3. Clean the drip tray and re-insert it.

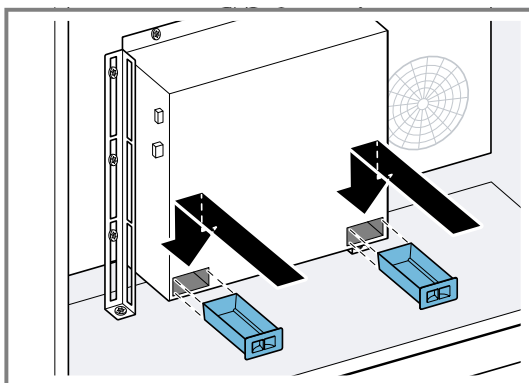

## 10.6 Removing the grease filter

1. Press .
- ✓ The glass panel moves halfway down and the grease filter cartridges are transported to the top.
2. Remove the grease filters upwards.

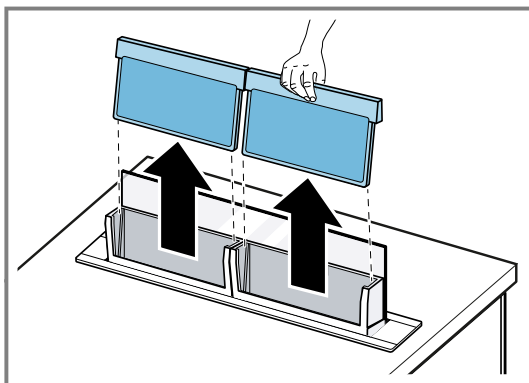

To avoid causing damage, do not bend the grease filters.

## 10.7 Cleaning grease filters manually

The grease filters filter the grease from the cooking vapour. Regularly cleaned grease filters guarantee a high level of grease removal. We recommend cleaning the grease filters every two months.

### ⚠ **WARNING – Risk of fire!**

Fatty deposits in the grease filters may catch fire.  
▶ Clean the grease filters regularly.

**Requirement:** The grease filters have been removed.

→ "Removing the grease filter", Page 12

1. Observe the information regarding the cleaning agents.
2. Soak the grease filter in hot soapy water. Use special grease solvent for stubborn dirt. You can obtain grease solvents from customer service or the online shop.
3. Use a brush to clean the grease filters.
4. Rinse the grease filters thoroughly.
5. Allow the grease filters to drain.

## 10.8 Cleaning grease filters in the dishwasher

The grease filters filter the grease from the cooking vapour. Regularly cleaned grease filters guarantee a high level of grease removal. We recommend cleaning the grease filters every two months.

### ⚠ **WARNING – Risk of fire!**

Fatty deposits in the grease filters may catch fire.

- ▶ Clean the grease filters regularly.

### **ATTENTION**

The grease filters may become damaged if they are squeezed in the dishwasher.

- ▶ Do not squeeze the grease filters.

**Note:** When cleaning the grease filter in the dishwasher, light discolouration may occur. This discolouration has no effect on the performance of the metal grease filters.

**Requirement:** The grease filters have been removed.

→ "Removing the grease filter", Page 12

1. Observe the information regarding the cleaning agents.
2. Place the grease filters loosely into the dishwasher. Do not clean heavily soiled grease filters with utensils. Use special grease solvent for stubborn dirt. You can obtain grease solvents from customer service or the online shop.
3. Start the dishwasher. Select a temperature of no more than 70 °C.
4. Allow the grease filters to drain.

## 10.9 Removing the grease filter cartridge

- ▶ **Note:** The appliance frame is sensitive. Remove the grease filter cartridges vertically. Do not pull the grease filter cartridges over the appliance frame. Remove the grease filter cartridges.

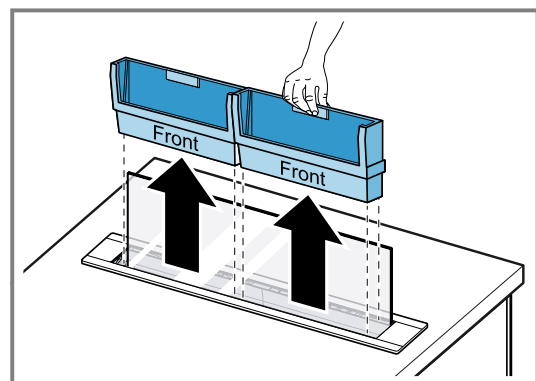

## 10.10 Cleaning the grease filter cartridge

**Requirement:** The grease filters have been removed.

→ "Removing the grease filter", Page 12

1. Clean the grease filter cartridge.  
You can clean the grease filter cartridges by hand or in the dishwasher.
2. Observe the information regarding the cleaning agents.

## 10.11 Fitting the grease filters

1. Press .
- ✓ The glass panel moves halfway down and the grease filter cartridges are transported to the top.

2. Insert the grease filter into the grease filter cartridges.

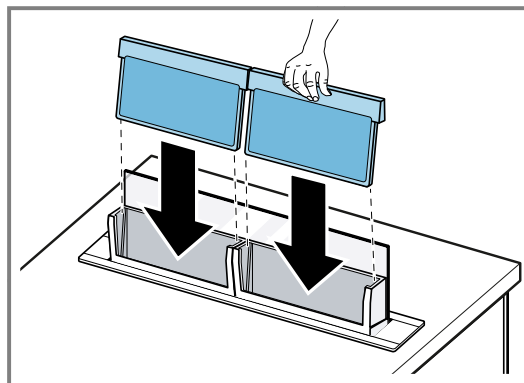

To avoid causing damage, do not bend the grease filters.

3. Press .
- ✓ The glass panel and the filter cartridges move downwards.
- ✓ The appliance flap closes and the appliance switches off.
4. Reset the saturation indicator.  
→ "Resetting the saturation indicator", Page 9

# 11 Troubleshooting

You can rectify minor faults on your appliance yourself. Read the troubleshooting information before contacting after-sales service. This will avoid unnecessary costs.

**Tip:** Permanently connect your appliance to the Home Connect app to automatically receive software updates. This allows errors to be eliminated, performance to be improved and new functions to be made available.

### **WARNING – Risk of injury!**

Improper repairs are dangerous.

- ▶ Repairs to the appliance should only be carried out by trained specialist staff.
- ▶ If the appliance is defective, call Customer Service.  
→ "Customer Service", Page 14

### **WARNING – Risk of electric shock!**

Improper repairs are dangerous.

- ▶ Repairs to the appliance should only be carried out by trained specialist staff.
- ▶ Only use genuine spare parts when repairing the appliance.
- ▶ If the power cord of this appliance is damaged, it must be replaced by trained specialist staff.

## 11.1 Malfunctions

Fault	Cause and troubleshooting
The appliance is not working.	The mains plug of the power cord is not plugged in. ▶ Connect the appliance to the power supply.
	The circuit breaker in the fuse box has tripped. ▶ Check the circuit breaker in the fuse box.
	There has been a power cut. ▶ Check whether the lighting in your room or other appliances are working.
	The glass panel is not inserted correctly. ▶ Insert the glass panel carefully as far as it will go.
	Liquid flows into the appliance. ▶ Pull out the mains plug or switch off the appliance at the circuit breaker in the fuse box. ▶ Empty the drip trays and remove the grease filters cartridges. → Page 11 ▶ Dry all accessible places. ▶ Leave the appliance flap open and restart the appliance only after 48 hours.

Fault	Cause and troubleshooting
The appliance is not working.	<ul style="list-style-type: none"> <li>▶ Insert the drip tray and the grease filters cartridges.</li> </ul> <hr/> <p>The glass panel is removed, and the appliance has been operated.</p> <ul style="list-style-type: none"> <li>▶ Insert the glass panel and disconnect the appliance from the power supply for approx. one minute.</li> </ul>
The appliance flap does not close completely.	<p>An object is jammed in the appliance.</p> <ul style="list-style-type: none"> <li>▶ Disconnect the appliance from the electricity.</li> <li>▶ Carefully open the flap and remove the object that has become jammed.</li> <li>▶ Close the flap carefully.</li> <li>▶ Connect the appliance to the power supply.</li> </ul>
The button illumination does not work.	<p>The control unit is faulty.</p> <ul style="list-style-type: none"> <li>▶ Call .</li> </ul> <p>→ <i>"Customer Service", Page 14</i></p>
The lighting does not work <sup>1</sup> .	<p>Different causes are possible.</p> <ul style="list-style-type: none"> <li>▶ Call .</li> </ul> <p>→ <i>"Customer Service", Page 14</i></p> <ul style="list-style-type: none"> <li>▶ Defective LED lights may be replaced by the manufacturer, their customer service or a qualified technician (electrician) only.</li> </ul>
The top two LEDs flash in the left-hand control panel (7).	<p>The grease filters are saturated.</p> <ul style="list-style-type: none"> <li>▶ Clean the grease filters.</li> </ul> <p>→ <i>"Cleaning grease filters in the dishwasher", Page 12</i></p> <p>→ <i>"Cleaning grease filters manually", Page 12</i></p> <p>→ <i>"Familiarising yourself with your appliance", Page 6</i></p>
The bottom two LEDs flash in the left-hand control panel (6).	<p>The odour filters are saturated.</p> <ul style="list-style-type: none"> <li>▶ Change the odour filter.</li> </ul> <p>→ <i>"Familiarising yourself with your appliance", Page 6</i></p>
Home Connect is not working properly.	<p>Different causes are possible.</p> <ul style="list-style-type: none"> <li>▶ Go to <a href="http://www.home-connect.com">www.home-connect.com</a>.</li> </ul>
The hob-based hood control is not working properly.	<p>It may be necessary to change the settings.</p> <ul style="list-style-type: none"> <li>▶ Read the instruction manual for the hob.</li> <li>▶ Go to <a href="http://www.home-connect.com">www.home-connect.com</a>.</li> </ul>
The appliance switches off in automatic mode even though cooking is still in progress.	<p>Pure steam or long cooking processes with only slight changes in odour may not be detected by automatic mode.</p> <ul style="list-style-type: none"> <li>▶ Switch on a manual fan setting.</li> </ul>

## 12 Disposal

### 12.1 Disposing of old appliance

Valuable raw materials can be reused by recycling.

1. Unplug the appliance from the mains.
2. Cut through the power cord.
3. Dispose of the appliance in an environmentally friendly manner.  
Information about current disposal methods are available from your specialist dealer or local authority.



This appliance is labelled in accordance with European Directive 2012/19/EU concerning used electrical and electronic appliances (waste electrical and electronic equipment - WEEE). The guideline determines the framework for the return and recycling of used appliances as applicable throughout the EU.

## 13 Customer Service

Function-relevant genuine spare parts according to the corresponding Ecodesign Directive can be obtained from Customer Service for a period of at least 10 years from the date on which your appliance was placed on the market within the European Economic Area.

Furthermore, our Customer Service will continue to provide you with other function-relevant and storable genuine spare parts for up to 15 years from the date on which your appliance was placed on the market.

<sup>1</sup> Depending on the appliance specifications

For more information, please contact our Customer Service team.

**Note:** Under the terms of the manufacturer's warranty the use of Customer Service is free of charge.

Detailed information about the warranty period and the warranty conditions in your country is available via the QR code on the enclosed document on service contacts and warranty conditions, from our customer service or on our website.

You can find the contact details for our customer service via the QR code on the enclosed document on service contacts and warranty conditions or on our website.

### 13.1 Product number (E-Nr.) and production number (FD)

If you contact Customer Service, you will require the product number (E-Nr.) and the production number (FD), which you can find on the appliance's rating plate. The rating plate is located on the fan box.

Make a note of your appliance's details and the Customer Service telephone number to find them again quickly.

## 14 Accessories

You can buy accessories from the after-sales service, from specialist retailers or online. Only use original accessories, as these have been specifically designed for your appliance.

Accessories vary from one appliance to another. When purchasing accessories, always quote the exact product number (E no.) of your appliance. → *Page 15*

You can find out which accessories are available for your appliance in our catalogue, in the online shop or from our after-sales service.

[www.neff-home.com](http://www.neff-home.com)

## 15 Declaration of Conformity

BSH Hausgeräte GmbH hereby declares that the appliance with Home Connect functionality conforms to the basic requirements and other relevant provisions of Directive 2014/53/EU.

A detailed RED Declaration of Conformity can be found online at [www.neff-home.com](http://www.neff-home.com) among the additional documents on the product page for your appliance.



Hereby, BSH Hausgeräte GmbH declares that the appliance with Home Connect functionality is in compliance with relevant statutory requirements.<sup>1</sup>

A detailed Declaration of Conformity can be found online at [www.neff-home.com/uk](http://www.neff-home.com/uk) among the additional documents on the product page for your appliance.<sup>1</sup>



2.4 GHz band (2400–2483.5 MHz): Max. 100 mW

5-GHz band (5150–5350 MHz + 5470–5725 MHz): max. 50 mW



BE	BG	CZ	DK	DE	EE	IE	EL	ES
FR	HR	IT	CY	LI	LV	LT	LU	HU
MT	NL	AT	PL	PT	RO	SI	SK	FI
SE	NO	CH	TR	IS	UK (NI)			

5 GHz WLAN (Wi-Fi): For indoor use only.

AL	BA	MD	ME	MK	RS	UK	UA
----	----	----	----	----	----	----	----

5 GHz WLAN (Wi-Fi): For indoor use only.

<sup>1</sup> Only applies to Great Britain

## 15.1 Statement of Compliance for Great Britain

### Product type

This statement of compliance covers the products described in this information for use whose model identifier group is seen on the title page. The full model identifier is made up of the characters before the slash in the product number (E no.) which can be found on the rating plate. Alternatively, you can also find the model identifier in the first line of the UK Energy Label.

### Name and address of manufacturer

BSH Hausgeräte GmbH, Carl-Wery-Strasse 34, 81739 München, Germany

This statement of compliance is prepared by the manufacturer.

The manufacturer, BSH Hausgeräte GmbH deems that it has complied with

- provision 5.1-1 of ETSI EN 303 645 v2.1.1 and, where relevant, provision 5.1-2 of ETSI EN 303 645 v2.1.1;
- provision 5.2-1 of ETSI EN 303 645 v2.1.1;
- provision 5.3-13 of ETSI EN 303 645 v2.1.1.

### Support period

BSH Hausgeräte GmbH will provide security updates that are necessary to maintain the main functions free of charge until at least 28/02/2034.

## 16 Test information

This information has been produced to facilitate the inspection of the appliance.

- Measured in accordance with EN 61591.
- The appliance is operated in its as-delivered condition.
- The fan box must be attached on the front of the appliance.

- Ensure that the filters do not move during the measurement (by changing the appliance position to the installation position).
- The ambient light is not a working light. The ambient light in light colour red has been added to the FDE value as a power consumer.

## 17 Installation instructions

Observe this information when installing the appliance.

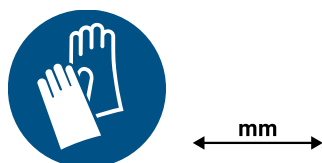

### 17.1 Included with the appliance

After unpacking all parts, check for any damage in transit and completeness of the delivery.

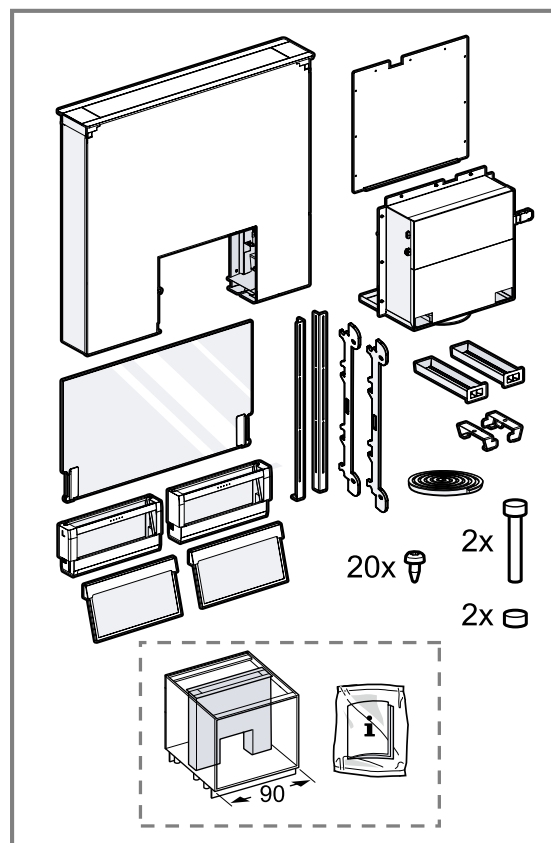

## 17.2 Appliance dimensions

You will find the dimensions of the appliance here

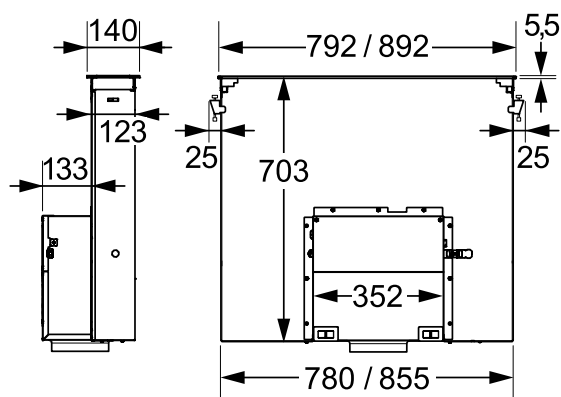

Observe the dimensions of the unit.

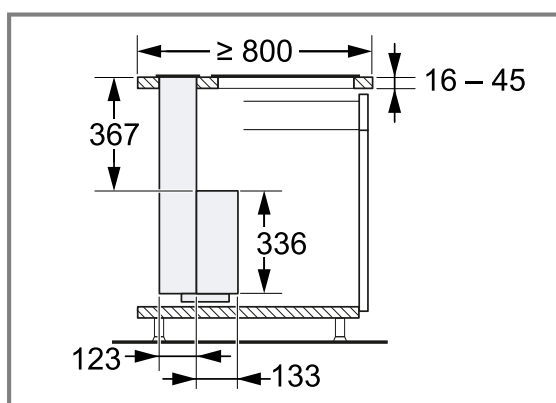

## 17.3 Secure installation

Follow these safety instructions when installing the appliance.

### **WARNING – Risk of poisoning!**

Risk of poisoning from flue gases being drawn back in. Room-air-dependent heat-producing appliances (e.g. gas, oil, wood or coal-operated heaters, continuous flow heaters or water heaters) obtain combustion air from the room in which they are installed and discharge the exhaust gases into the open through an exhaust gas system (e.g. a chimney). With the extractor hood switched on, air is extracted from the kitchen and the adjacent rooms.

Without an adequate supply of air, the air pressure falls below atmospheric pressure. Toxic gases from the chimney or the extraction shaft

are sucked back into the living space.

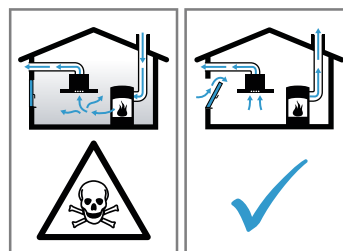

- ▶ Always ensure adequate fresh air in the room if the appliance is being operated in exhaust air mode at the same time as a room-air-dependent heat-producing appliance is being operated.
- ▶ It is only possible to safely operate the appliance if the pressure in the room in which the heating appliance is installed does not fall below 4 Pa (0.04 mbar). This can be achieved whenever the air needed for combustion is able to enter through openings that cannot be sealed, for example in doors, windows, incoming/exhaust air wall boxes or by other technical means. An incoming/exhaust air wall box alone is not sufficient to ensure compliance with the limit.
- ▶ In any case, consult your responsible chimney sweep. They are able to assess the house's entire ventilation setup and will suggest the suitable ventilation measures to you.

Risk of poisoning from flue gases being drawn back in.

- ▶ If an extractor hood with an open-flued heat production source is installed, the power supply for the extractor hood must be provided with a suitable safety switch.

Risk of poisoning from flue gases being drawn back in.

- ▶ Do not emit the exhaust air into a smoke or exhaust gas flue that is in operation.
- ▶ Do not emit the exhaust air into a shaft that is used to ventilate installation rooms for heat-producing appliances.
- ▶ If the exhaust air is to be conveyed into a smoke or exhaust gas flue, you must obtain the consent of the heating engineer responsible.

### **WARNING – Risk of suffocation!**

Children may put packaging material over their heads or wrap themselves up in it and suffocate.

- ▶ Keep packaging material away from children.

- ▶ Do not let children play with packaging material.

**⚠ WARNING – Risk of fire!**

The grease deposits in the grease filter may catch fire.

- ▶ Never work with naked flames close to the appliance (e.g. flambéing).
- ▶ Do not install the appliance near a heat-producing appliance for solid fuel (e.g. wood or coal) unless a closed, non-removable cover is present. There must be no flying sparks.
- ▶ The specified safety clearances must be complied with in order to prevent a build-up of heat.

**⚠ WARNING – Risk of injury!**

Components inside the appliance may have sharp edges.

- ▶ Wear protective gloves.

The appliance is heavy.

- ▶ To move the appliance, two people are required.
- ▶ Use only suitable tools and equipment.

Changes to the electrical or mechanical assembly are dangerous and may lead to malfunctions.

- ▶ Do not make any changes to the electrical or mechanical assembly.

**⚠ WARNING – Risk of fire!**

Unsuitable appliance combinations may cause damage.

- ▶ Do not use the appliance in combination with gas hobs.

**⚠ WARNING – Risk of electric shock!**

Sharp-edged components inside the appliance may damage the connecting cable.

- ▶ Do not kink or trap the connecting cable.

If the appliance or the power cord is damaged, this is dangerous.

- ▶ Never operate a damaged appliance.
- ▶ Never pull on the power cord to unplug the appliance. Always unplug the appliance at the mains.
- ▶ If the appliance or the power cord is damaged, immediately unplug the power cord or switch off the fuse in the fuse box.
- ▶ Call customer services. → *Page 14*

Improper repairs are dangerous.

- ▶ Repairs to the appliance should only be carried out by trained specialist staff.
- ▶ Only use genuine spare parts when repairing the appliance.

- ▶ If the power cord of this appliance is damaged, it must be replaced by trained specialist staff.

Incorrect installation is dangerous.

- ▶ Connect and operate the appliance only in accordance with the specifications on the rating plate.
- ▶ Connect the appliance to a power supply with alternating current only via a properly installed socket with earthing.
- ▶ The protective conductor system of the domestic electrical installation must be properly installed.
- ▶ Never equip the appliance with an external switching device, e.g. a timer or remote control.
- ▶ When the appliance is installed, the mains plug of the power cord must be freely accessible. If free access is not possible, an all-pole isolating switch must be installed in the permanent electrical installation according to the conditions of Overvoltage Category III and according to the installation regulations.
- ▶ When installing the appliance, check that the connection cable is not trapped or damaged.

**⚠ WARNING – Danger: Magnetism!**

The removable profiles are magnetic and may affect electronic implants, e.g. pacemakers or insulin pumps.

- ▶ Persons with electronic implants must stay at least 10 cm away from the magnetic profiles.

## 17.4 General information

Follow these general instructions during the installation.

- For the installation, observe the currently valid building regulations and the regulations of the local electricity and gas suppliers.
- When discharging the exhaust air, the official and legal regulations, such as the regional building code, must be observed.
- In order to freely access the fan box for servicing, select an easy-to-reach installation site.
- The surfaces of the appliance are sensitive. Avoid damaging them during installation.

## 17.5 Information on the installation situation

- Install this appliance in a worktop.
- The appliance is not suitable for combined operation with a gas hob.
- To install additional special accessory parts, observe the enclosed installation instructions.
- The width of the extractor hood must correspond at least with the width of the hob.

- To optimally detect the cooking vapours, install the appliance behind the hob.

To ensure that the appliance does not lose any power, do not install any wall units above the appliance and maintain the following clearances:

- At least 50 cm to the left and right from the appliance to a wall or to an adjacent wall unit
- At least 5 cm from the frame of the appliance to a wall

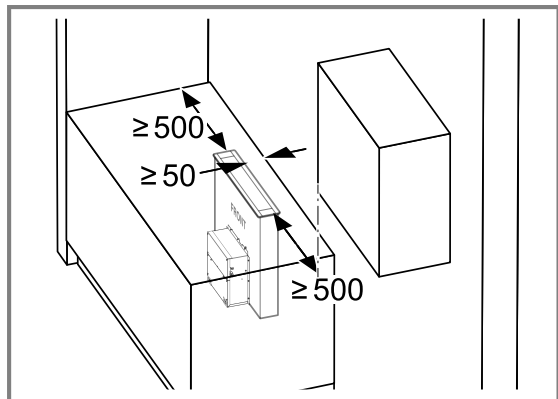

- At least 2 cm from the Guided Air suction area to a unit wall

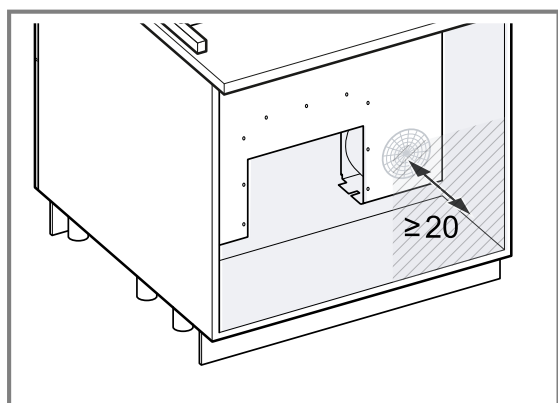

- Include a ventilation opening in the base with a cross-section of 80 cm<sup>2</sup>.

## 17.6 Instructions for the exhaust air pipe

The appliance manufacturer does not provide any warranty for faults attributable to the pipeline.

- Use a short, straight exhaust air pipe with as large a pipe diameter as possible.
- Long, rough exhaust air pipes, many pipe bends or small pipe diameters reduce the suction power and increase the fan noise.
- Use an exhaust pipe that is made of non-combustible material.
- To prevent condensate from returning, fit the exhaust pipe with a 1° gradient from the appliance.

**Note:** Suitable air extraction ducts are available from our after-sales service, your dealer or on our website.

### Flat ducts

Use flat ducts with an inner cross-section that corresponds to the diameter of the round pipes:

- Diameter of 150 mm corresponds to approx. 177 cm<sup>2</sup>.

- Diameter of 120 mm corresponds to approx. 113 cm<sup>2</sup>.
- Use sealing strips for different pipe diameters.
- Do not use any flat ducts with sharp bends.

### Round pipes

Use round pipes with an inner diameter of 150 mm (recommended) or at least 120 mm.

## 17.7 Installation

### Checking the units

- ▶ Check whether the fitted unit is level and has sufficient load-bearing capacity. The maximum weight of the appliance is 40 kg.

### Preparing the units

**Note:** To install the hob and the appliance seamlessly, you require special accessories, which are not included in the scope of delivery. Observe the enclosed installation instructions for special accessories.

**Requirement:** The unit is suitable for the installation.

1. Make a cut-out in the worktop, depending on the installation position.

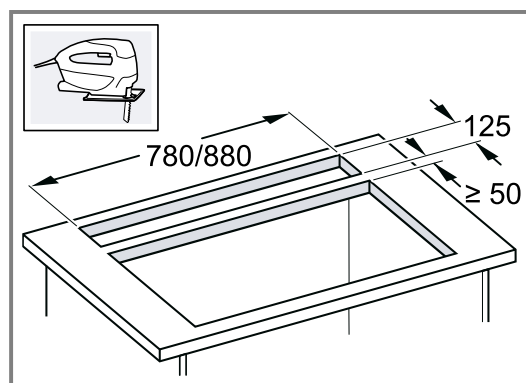

The angle between the cut surface and the worktop must be 90°.

2. Ensure that the worktop has sufficient load-bearing capacity and stability. Use a heat- and humidity-resistant reinforcing material for any substructure.
3. Ensure that the fitted unit is still stable after the cut-outs have been made.
4. Remove any shavings.
5. Depending on the installation position, remove the back panel of the fitted unit.

### Preparing the appliance

#### ⚠ WARNING – Risk of injury!

The appliance is heavy.

- ▶ To move the appliance, two people are required.
- ▶ Use only suitable tools and equipment.

1. Place the appliance on a soft surface and remove the transit bolt.

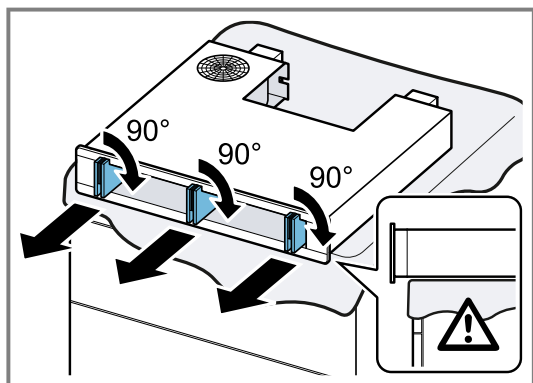

2. Pull the cable connection into the strain relief ① and remove the transit bolt ②.

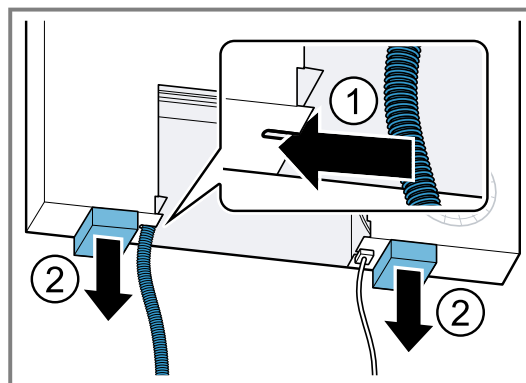

2. Stick the seal in the designated groove ① and trim it ②.

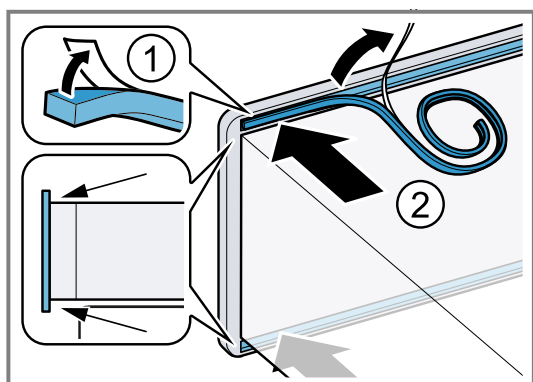

3. **Note:** To ensure that the appliance is not yet fully inserted into the cut-out, place a slat below the short side of the appliance in each case. Insert the appliance into the cut-out in the worktop from above.

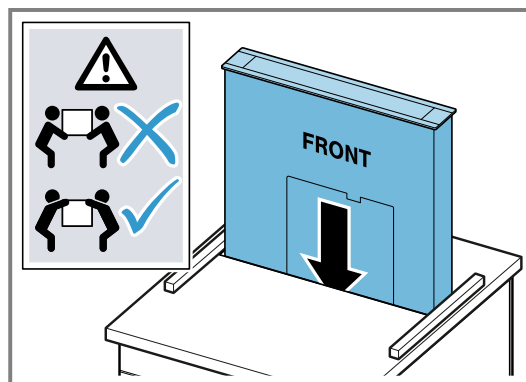

3. Screw the cover plate in tightly, depending on the installation situation.

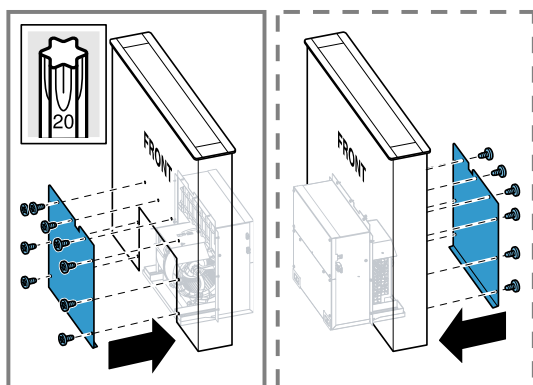

- Insert the appliance evenly so that it is not tilted.
4. Mark the cut-out for the pipework:
    - ▶ Attach the exhaust air hose for the fan box to the connector.
    - ▶ Slide the fan box into the guide and tighten this with a screw.
    - ▶ Mark the position of the pipework on the bottom of the unit.
    - ▶ Undo the screw and remove the fan box again.
  5. Saw out the cut-out for the pipework.

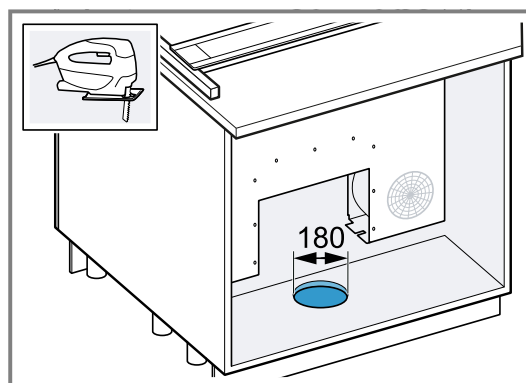

### Installing the appliance

#### ⚠ WARNING – Risk of injury!

Components inside the appliance may have sharp edges.

- ▶ Wear protective gloves.
- The appliance is heavy.
- ▶ To move the appliance, two people are required.
- ▶ Use only suitable tools and equipment.

**Note:** To protect the cables, do not remove the transit bolt yet.

1. Lift the appliance by the short sides and align the front of the appliance with the hob.

6. Slide the fan box into the guide, connect the pipework and screw the fan box tightly back in place.

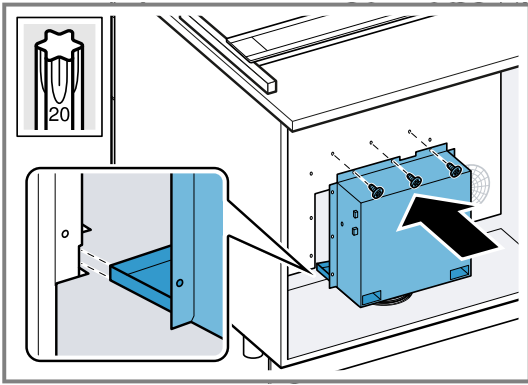

7. Support the appliance from below and remove the slats.  
 8. Insert the appliance fully in the cut-out.  
 9. **Note:** The design profile holders are not grip elements. Do not grip the appliance by the design profile holders. Observe the enclosed installation instructions for special accessories. Insert the design profile holder onto the short side of the appliance.

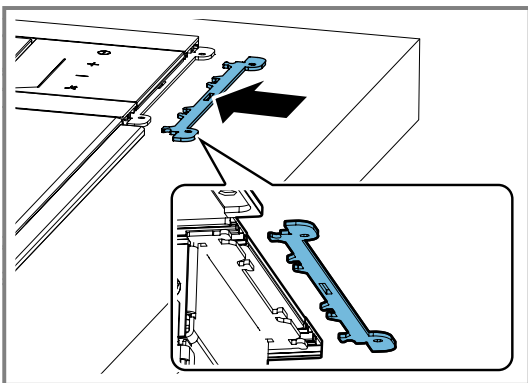

Lift the appliance approx. 5 mm in order to insert the design profile holder.

10. Align the rails to the bottom ① and attach to the side ②.

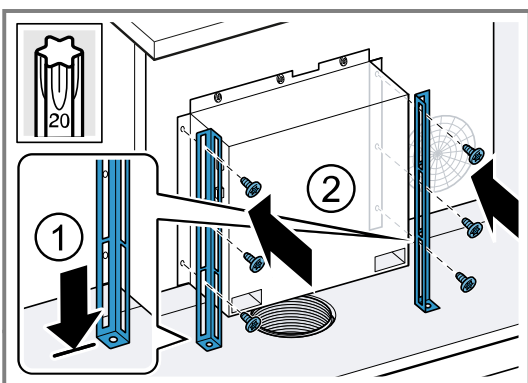

11. Screw the rails onto the bottom of the unit.

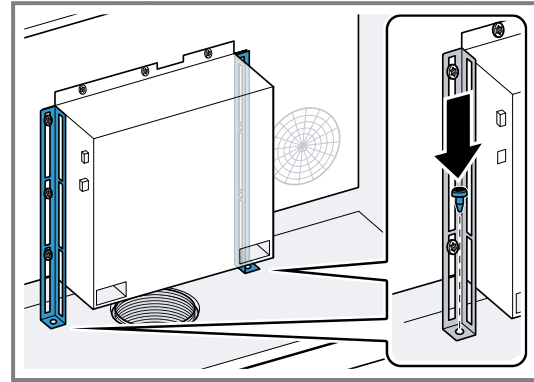

12. **Note:** If an appliance measuring 90 cm is installed in a unit with a width of 90 cm, skip the next two installation steps and follow the instructions in the additional accessory pack. Screw in the screw from below and tighten the nut.

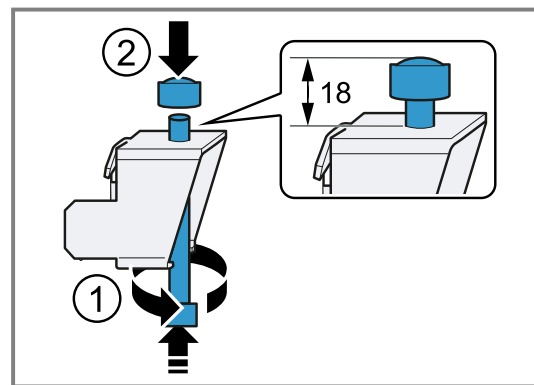

13. Align the appliance to the hob ① and tension it against the worktop ② ③.

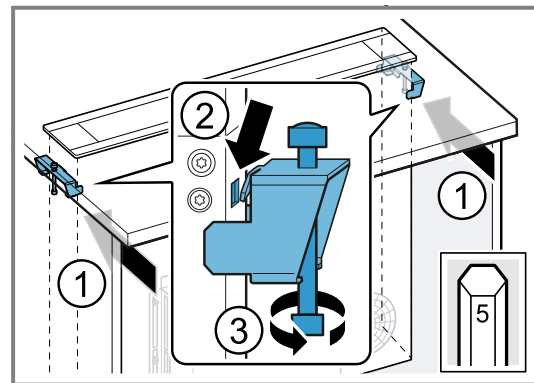

14. Insert the drip tray and snap it into place.

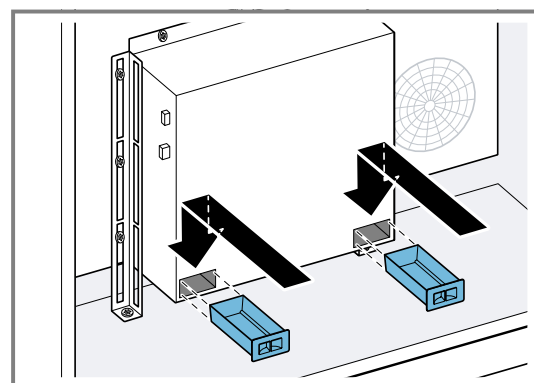







# Neff Home Connect App

Connect your home appliance today and enjoy the following benefits:

- **Focus entirely on cooking. The extractor hood starts automatically when you begin cooking. (Compatible hob required)**
- **Do not forget to maintain the filters. When it's time, you will receive an app notification.**
- **Explore a world of additional functions and services within the app and enjoy direct access with the favourites button on your extractor hood. (available on selected models)**

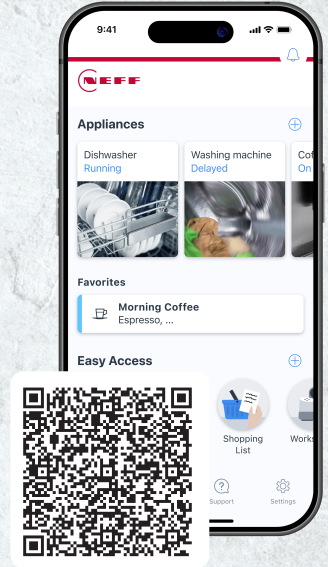

Valid within Great Britain:  
Imported to Great Britain by  
BSH Home Appliances Ltd.  
Grand Union House  
Old Wolverton Road  
Wolverton, Milton Keynes  
MK12 5PT  
United Kingdom



Register your product online  
[neff-home.com](https://neff-home.com)



**BSH Hausgeräte GmbH**  
Carl-Wery-Straße 34  
81739 München, GERMANY

9001843028 (060209) REG25  
en