

N 90, BUILT-IN OVEN WITH ADDED STEAM FUNCTION, 60 X 60 CM, STAINLESS STEEL B57VS26N0B



Z11AB15A0 Baking tray, non-stick ceramic coated, Z11AU15A0 Universal pan, non-stick ceramic coated, Z11CG10X0 Barbecue-Set, Z11CR10X0 Baking and roasting grid (standard), Z11GT10X3 Glass roasting dish, 5,4l, Z11GU20X0 Glasspan, Z11SZ00X0 SeamlessCombination mounting kit, Z11SZ80X0 SeamlessCombination 60 + 29cm, Z11SZ90X0 SeamlessCombination 60 + 45cm, Z11TC10X0 ComfortFlex Rail (1 level), Z11TC16X0 ComfortFlex Rail (1 level) and racks, Z12CB10A0 Baking tray, enamelled, Z12CL10A0 Lid for professional pan, enamelled, Z12CM10A0 Moussaka pan, enamelled, Z12CN10A0 Professional pan, enamelled, Z12CP10A0 Pizza pan, enamelled, Z12CQ10A0 Grill tray, enamelled, Z12CU10A0 Multipurpose pan, enamelled, Z12TF16X0 1 level telescopic rails, full ext,pyro, Z12TF36X0 3 level telescopic rails, full ext,pyro, Z13CR10X0 Baking and roasting grid (steam), Z13CV05S0 Cover Strip, Z1913X0 Baking Stone, Z19DD10X0 Steam set for ovens

Built-in oven with VarioSteam® and SLIDE&HIDE® - fuller flavour and unrestricted access to the oven interior.

- ✓ Slide&Hide® – The unique fully disappearing oven door.
- ✓ CircoTherm® – Smart hot-air solution that lets you bake on up to four levels.
- ✓ VarioSteam – Adds steam to conventional heating functions, cooks food moist on the inside and crisp on the outside.
- ✓ Pyrolytic Self-Cleaning with Easy Clean - the duo for optimal cleaning: pyrolytic after heavy use and Easy Clean for in between
- ✓ ShiftControl - fast navigation through menus and simple operation with the TFT display

Color / Material Front:Stainless steel
 Built-in / Free-standing: Built-in
 Door opening: Drop down
 Cleaning : Pyrolytic+Hydrolytic
 Control Panel Material: Glass
 Door Material: Glass
 Dimensions (HxWxD): 595x596x548 mm
 Dimensions of the packed product (HxWxD): . 675 x 660 x 690 mm
 Min. required niche size for installation (HxWxD): 585-595 x 560-568 x 550 mm
 Cavity dimensions: 357 x 480 x 415 mm
 Usable volume of cavity: 71 l
 Number of interior lights: 1
 Net weight: 42.9 kg
 Gross weight: 45.5 kg
 EAN code: 4242004183143
 Connection Rating: 3450 W
 Fuse protection: 16 A
 Voltage: 220-240 V
 Frequency: 60; 50 Hz
 Length electrical supply cord: 120.0 cm



*N 90, BUILT-IN OVEN WITH ADDED STEAM
FUNCTION, 60 X 60 CM, STAINLESS STEEL
B57VS26N0B*

Heating Functions

- Oven with 13 heating methods:
- CircoTherm®, Defrost, Bread Baking, Full surface grill, CircoTherm® Eco, Centre area grill, Top/bottom heating, Top/bottom heating Eco, Pizza Setting, Low temperature cooking, Bottom heating, Circo-roasting, Keep warm
- Additional heating methods with steam: Reheating, Dough Proving
- Automatic temperature proposal, Actual temperature display, Optical temperature control, Meat probe function
- Temperature range 40 °C - 275 °C
- Cavity volume: 71 net usable litres
- Number of shelf levels: 4
- Full glass inner door - safer touch door

Design

- Cavity inner surface: enamel
- Illuminated ShiftControl

Cleaning

- Pyrolytic self cleaning
- EasyClean® program

Convenience

- 4.1" TFT colour and graphics display with ShiftControl
- Additional functions: Descaling program
- Steam cooking function (system steamer accessory required)
Drying function
- Hide®, the fully retracting oven door
- Bake and Roast assist, Automatic programs
- MultiPoint MeatProbe
- Electronic clock with start / stop function
- Rapid heat-up
- LED light
- Water tank empty indicator
- Location of the steam generator is outside of the cavity
- Cooling fan
- Stainless-steel fan

Hook-in racks / rails

- Large capacity oven with shelf supports, Telescopic shelf rails available as optional accessory

Accessories

- 1 x universal pan, 2 x combination grid

Safety and Environment

- Quadruple glazed CoolTouch door
- Automatic door lock during pyrolysis, Individual adjustable child lock, Safety switch off, Residual heat indicator, Start button, Door contact switch

Technical Info

- Length of mains cable: 120 cm
- Total connected load electric: 3.45 KW

- Nominal voltage: 220 - 240 V
- Maximum door temperature 30° C

Dimensions

- Appliance dimensions (HxWxD): 595 mm x 596 mm x 548 mm
- Installation dimensions (HxWxD): 585 mm - 595 mm x 560 mm - 568 mm x 550 mm
- Please reference the built-in dimensions provided in the installation drawing

N 90, BUILT-IN OVEN WITH ADDED STEAM FUNCTION, 60 X 60 CM, STAINLESS STEEL B57VS26N0B

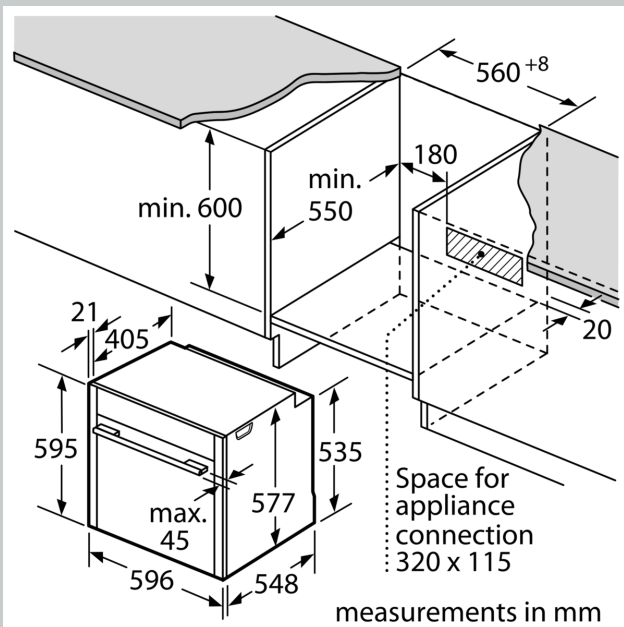
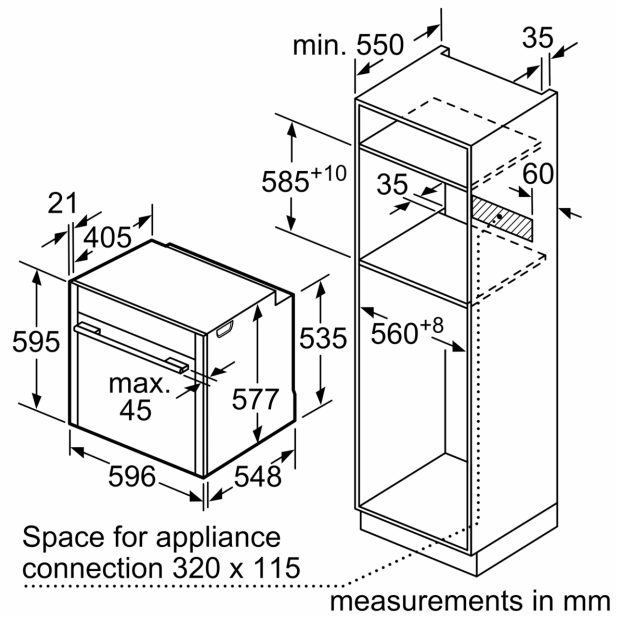
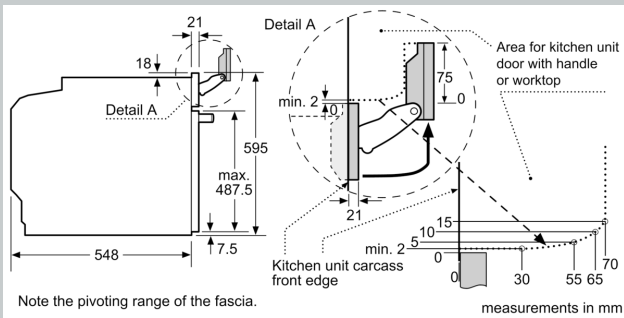

If the appliance will be installed underneath a hob, the following worktop thicknesses (including substructure if necessary) must be taken into account.

Hob type	min. worktop thickness	
	fitted	flush
Induction hob	37 mm	38 mm
Full surface Induction hob	47 mm	48 mm
Gas hob	30 mm	38 mm
Electric hob	27 mm	30 mm