

N 90, Built-in compact oven with added steam and microwave function, 60 x 45 cm, Stainless steel C28QT27N0

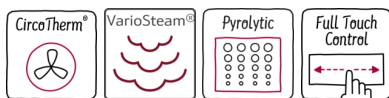

Built-in microwave with VarioSteam and MultiPoint meat probe for fast cooking with full flavour.

- ✓ CircoTherm® – Smart hot-air solution that lets you bake on up to four levels.
- ✓ VarioSteam – Adds steam to conventional heating functions, cooks food moist on the inside and crisp on the outside.
- ✓ Combined microwave and oven - the convenient solution to save space and time
- ✓ The duo for perfect cleaning: Pyrolysis after heavy use - the oven interior cleans itself. EasyClean® - the environment-saving option for fast oven cleaning.
- ✓ Full Touch Control – Simple, precise control by touch on the high-resolution TFT colour display.

Features

Technical Data

Type of micro-wave oven : MW-Combi
 Type of control : Electronic
 Color / Material Front : Stainless steel
 Cavity dimensions : 237.0 x 480 x 392.0 mm
 Approval certificates : CE, VDE
 Length electrical supply cord : 150 cm
 Net weight : 41.507 kg
 Gross weight : 43.8 kg
 EAN code : 4242004185079
 Maximum micro-wave power : 900 W
 Connection Rating : 3600 W
 Fuse protection : 16 A
 Voltage : 220-240 V
 Frequency : 60; 50 Hz
 Plug type : Gardy plug w/ earthing
 Cavity dimensions : 237.0 x 480 x 392.0 mm



N 90, Built-in compact oven with added steam and microwave function, 60 x 45 cm, Stainless steel C28QT27N0

Features

Heating Functions

- Compact oven with microwave with 12 heating methods:
 - Hot Air
 - Full surface grill
 - CircoTherm® Eco
 - Centre area grill
 - Top/bottom heating
 - Top/bottom heating Eco
 - CircoTherm® Intensive
 - Low temperature cooking
 - Bottom heating
 - Circo-roasting
 - Plate warming
 - Keep warm
- Additional heating methods with steam: Reheating, Dough Proving
- Additional heating methods with microwave: Pure microwave, Combination microwave and conventional oven
- Max. Power: 900 W; 5 Microwave power settings (90 W, 180 W, 360 W, 600 W, 900 W) with Inverter (MW)
- Intelligent inverter technology: maximum output power will be regulated to 600 W when used in longer operation
- Cavity volume: 45 net usable litres

Design

- Anthracite enamel cavity with 3 shelf positions

Cleaning

- Pyrolytic self cleaning
- EasyClean® Cleaning aid program

Convenience

- 5.7" TFT colour and graphics Display with FullTouch control
- Drop down door, SoftMove oven door with soft open and soft close, SoftOpen
- Bake and Roast assist, Automatic programs
- Number of automatic programmes: 32
- MultiPoint MeatProbe
- Electronic clock with start / stop function
- Rapid heating-up: automatic
- LED lighting
- Large 1 litre water tank
- Water tank empty indicator
- Location of the steam generator is outside of the cavity
- Cooling fan
- Stainless-steel fan

Hook-in racks / rails

Accessories

- 1 x universal pan, 1 x enamel baking tray, 1 x combination grid

Safety and Environment

- Automatic door lock during pyrolysis
- Automatic door lock during pyrolysis
- Individual adjustable child lock
- Safety switch off
- Residual heat indicator
- Start button
- Door contact switch

Technical Info

- Length of mains cable: 150 cm
- Total connected load electric: 3.6 KW
- Appliance dimensions (HxWxD): 455 mm x 596 mm x 548 mm
- Installation dimensions (HxWxD): 450 mm - 455 mm x 560 mm - 568 mm x 550 mm
- Please reference the built-in dimensions provided in the installation drawing

N 90, Built-in compact oven with added steam and microwave function, 60 x 45 cm, Stainless steel
C28QT27N0

Dimensioned drawings

Installation with a hob.

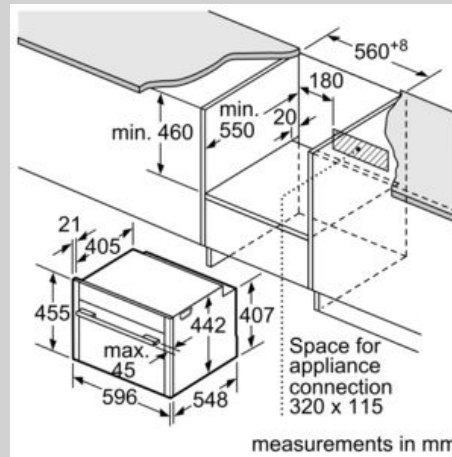
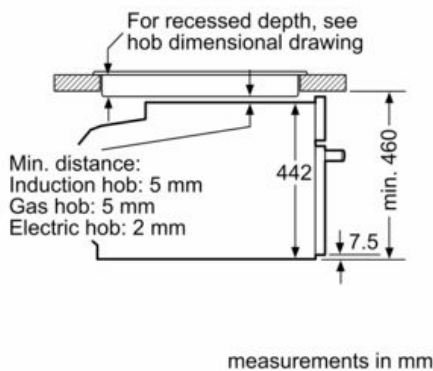

If the compact appliance will be installed underneath a hob, the following worktop thicknesses (including substructure if necessary) must be taken into account.

Hob type	min. worktop thickness	
	fitted	flush
Induction hob	42 mm	43 mm
Full surface Induction hob	52 mm	53 mm
Gas hob	32 mm	43 mm
Electric hob	32 mm	35 mm

