

N 70, BUILT-IN MICROWAVE OVEN, FLEX DESIGN  
NL9WR21Y1A



38cm Built-in microwave.

- ✓ 3,7" Full Touch TFT Display - Intuitive navigation for easy use and complete control.
- ✓ Flex Design - Choose a finishing touch to match your kitchen's aesthetic – now and later!
- ✓ Seamless Combination with Flex Design - Watch your favourite appliances blend together seamlessly.
- ✓ Easy Clean – easy cleaning within a couple of minutes
- ✓ Automatic programmes - Your kitchen helper.

Z9038AY0	FlexDesign AG 38 MW 38
Z9038BY0	FlexDesign BB 38 MW 38
Z9038DY0	FlexDesign DB 38 MW 38
Z9038MY0	FlexDesign MS 38 MW 38
Z9098AY0	SC FlexDesign AG 98 60 + MW 38
Z9098BY0	SC FlexDesign BB 98 60 + MW 38
Z9098DY0	SC FlexDesign DB 98 60 + MW 38
Z9098MY0	SC FlexDesign MS 98 60 + MW 38

Z9038AY0	FlexDesign AG 38 MW 38
Z9038BY0	FlexDesign BB 38 MW 38
Z9038DY0	FlexDesign DB 38 MW 38
Z9038MY0	FlexDesign MS 38 MW 38
Z9098AY0	SC FlexDesign AG 98 60 + MW 38
Z9098BY0	SC FlexDesign BB 98 60 + MW 38
Z9098DY0	SC FlexDesign DB 98 60 + MW 38
Z9098MY0	SC FlexDesign MS 98 60 + MW 38

Type of micro-wave oven: .....	MW only
Built-in / Free-standing: .....	Built-in
Door opening: .....	Button
Cleaning : .....	Hydrolytic
Control Panel Material: .....	Glass
Dimensions (HxWxD): .....	382 x 596 x 318 mm
Dimensions of the packed product (HxWxD): .	470 x 460 x 670 mm
Min. required niche size for installation (HxWxD): .....	362-382 x 560-568 x 300 mm
Cavity dimensions: .....	220 x 350 x 270 mm
Cavity capacity: .....	21 l
Maximum micro-wave power: .....	900 W
Number of interior lights: .....	1
Net weight: .....	15.4 kg
Gross weight: .....	17.2 kg
EAN code: .....	4242004266716
Connection Rating: .....	1220 W
Fuse protection: .....	10 A
Voltage: .....	220-240 V
Frequency: .....	50; 60 Hz
Length electrical supply cord: .....	175.0 cm



## N 70, BUILT-IN MICROWAVE OVEN, FLEX DESIGN NL9WR21Y1A

### Microwave and heating methods

- Max. Power: 900 W; 5 Microwave power settings: 90 W, 180 W, 360 W, 600 W, 900 W
- Intelligent inverter technology: maximum output power will be regulated to 600 W when used in longer operation

### Design

- Flex Design (available in four colours)
- Stainless steel cavity with glass bottom
- ShiftControl
- Touch key operation

### Cleaning

- EasyClean® program

### Convenience

- Electronic clock with start / stop function
- Electronic Control, 3.7" Full Touch TFT Display
- User-friendly electronics: extremely easy and comfortable operation
- 7 automatic cooking programs
- LED light
- Cavity volume: 21 l
- Left hinged door

### Safety and Environment

- Start button, Door contact switch
- Cooling fan

### Technical Info

- Length of mains cable: 175 cm
- Total connected load electric: 1.22 KW
- Nominal voltage: 220 - 240 V
- Appliance: 382 x 596 x 318 mm

### Dimensions

- Appliance dimensions (HxWxD): 382 mm x 596 mm x 318 mm
- Installation dimensions (HxWxD): 362 mm - 382 mm x 560 mm - 568 mm x 300 mm
- Please reference the built-in dimensions provided in the installation drawing

N 70, BUILT-IN MICROWAVE OVEN, FLEX DESIGN  
NL9WR21Y1A

Measurements in mm

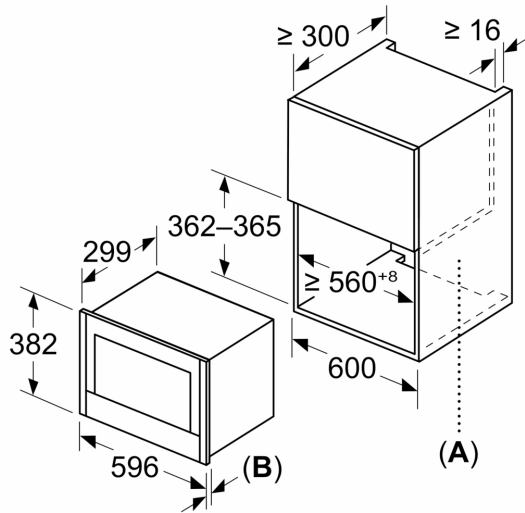

**A:** Back wall open  
**B:** 22.6 mm

Measurements in mm

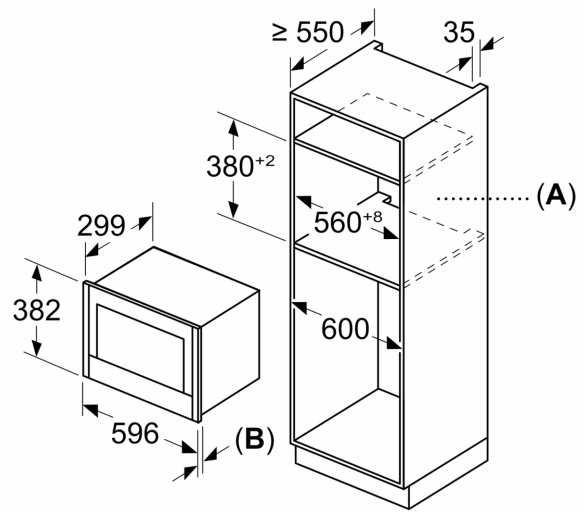

**A:** Back wall open  
**B:** 22.6 mm

measurements in mm

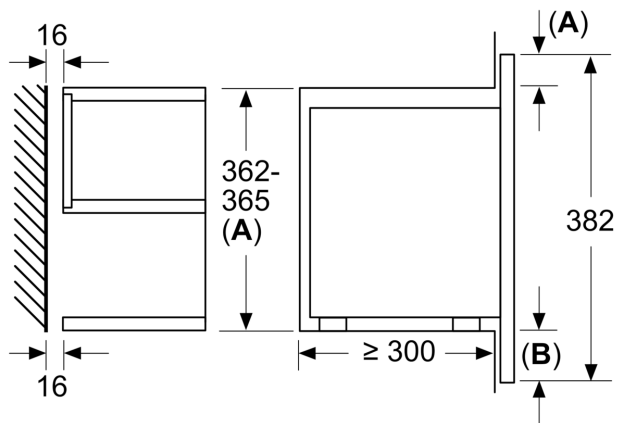

**A:** Overhang at top:  
Recess 362: 6 mm  
Recess 365: 3 mm  
**B:** Overhang at bottom: 14 mm