

N 50, BUILT-IN DOUBLE OVEN
U2ACH7CG0A

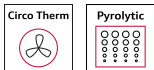

Z1608BX0 Full ext rails, level independent, Z1650BE0 Half tray, Z1655CA0 Air Fry & Grill tray, Z1913X0 Baking Stone, Z19DD10X0 Steam set for ovens, Z11AB15A0 Baking tray, non-stick ceramic coated, Z11AU15A0 Universal pan, non-stick ceramic coated, Z11CR10X0 Baking and roasting grid (standard), Z11GT10X3 Glass roasting dish, 5,4l, Z11GU20X0 Glasspan, Z11TI15X0 Cliprails, Z12CB10A0 Baking tray, enamelled, Z12CL10A0 Lid for professional pan, enamelled, Z12CN10A0 Professional pan, enamelled, Z12CP10A0 Pizza pan, enamelled, Z12CU10A0 Multipurpose pan, enamelled, Z1365WX0 Wireless food thermometer, Z13CR10X0 Baking and roasting grid (steam)

Double built-in oven - perfect for grilling, baking and roasting of multiple dishes at the same time.

- ✓ CircoTherm® – The smart hot-air function lets you bake on up to three levels at once and achieve even cooking results.
- ✓ Pyrolytic Self-Cleaning with Easy Clean - the duo for optimal cleaning: pyrolytic after heavy use and Easy Clean for in between
- ✓ LCD-Display – simple, straightforward with large characters for clear reading

Color / Material Front: Graphite-Grey
 Built-in / Free-standing: Built-in
 Dimensions (HxWxD): 888 x 594 x 550 mm
 Dimensions of the packed product (HxWxD): . 960 x 660 x 690 mm
 Control Panel Material: Glass
 Door Material: Glass
 Net weight: 61.0 kg
 Usable volume of cavity: 71 l
 Heating functions: Bread Baking Setting, Full width grill, CircoTherm® gentle, Hot Air, Conventional heat, Pizza setting, Bottom heat, Hot Air grilling
 Oven control: electronic
 Number of interior lights: 1
 EAN code: 4242004265153
 Energy efficiency rating: A
 Energy consumption per cycle conventional (2010/30/EC): 1.02 kWh/cycle
 Energy consumption per cycle forced air convection (2010/30/EC): 0.81 kWh/cycle
 Energy efficiency class (2010/30/EC) - cavity 2: B
 Energy consumption per cycle conventional - cavity 2 (2010/30/EC): 0.83 kWh/cycle
 Energy efficiency index (2010/30/EC): 95.3 %
 Energy efficiency index cavity 2 (2010/30/EC): 120.3 %
 Connection Rating: 6300 W
 Fuse protection: 32 A
 Voltage: 220-240 V
 Frequency: 50 Hz
 Plug type: no plug, fixed connection
 Included accessories cavity 1: 1 x enamel baking tray, 2 x combination grid, 1 x universal pan



N 50, BUILT-IN DOUBLE OVEN U2ACH7CG0A

Heating Functions

- Temperature range 30 °C - 275 °C
- Cavity volume: 71 net usable litres

Hook-in racks / rails

- Number of shelf levels: 4
- 2 level fully extendable telescopic shelf rails, safety stop function

Design

- Graphite-Grey Edition
- Rotary Control, Retractable control knobs
- Cavity inner surface: enamel

Cleaning

- Pyrolytic self cleaning
- EasyClean® program
- Full glass inner door - safer touch door

Convenience

- LCD-display control (white)
- Electronic clock with start / stop function
- Automatic temperature proposal, automatic start, Actual temperature display, Optical temperature control
- Bar handle
- Rapid heat-up
- Halogen lighting
- Cooling fan
- Stainless-steel fan

Accessories

- 1 x enamel baking tray, 2 x combination grid, 1 x universal pan

Safety and Environment

- Maximum door temperature 30° C
- Quadruple glazed CoolTouch door
- Automatic door lock during pyrolysis, Individual adjustable child lock, Safety switch off, Residual heat indicator

Technical Info

- Nominal voltage: 220 - 240 V
- Total connected load electric: 6.3 KW

Dimensions

- Appliance dimensions (HxWxD): 888 mm x 594 mm x 550 mm
- Installation dimensions (HxWxD): 875 mm - 888 mm x 560 mm - 568 mm x 550 mm
- Please reference the built-in dimensions provided in the installation drawing

N 50, BUILT-IN DOUBLE OVEN
U2ACH7CG0A

measurements in mm

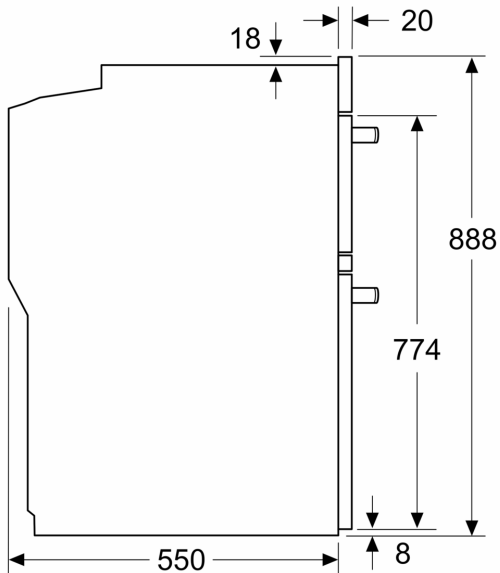

Back panel open

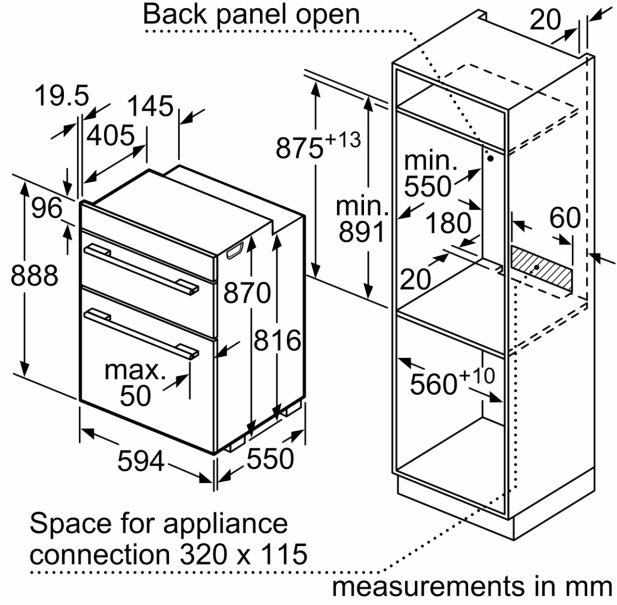

measurements in mm