

N 90, BUILT-IN OVEN WITH STEAM FUNCTION, 60 X 60 CM, STAINLESS STEEL
B47FS34H0B



A+



Built-in oven with FullSteam and SLIDE&HIDE® - combining all heating types and steam cooking in a single oven with unrestricted access

- ✓ Slide&Hide® – The fully disappearing oven door with rotating handle.
- ✓ CircoTherm® – Smart hot-air solution that lets you bake on up to four levels.
- ✓ Full Steam – Your oven is also a fully equipped steamer.
- ✓ Eco Clean with Base Clean - the duo that makes oven cleaning easier
- ✓ Shift Control - fast navigation through menus and simple operation with the TFT display.

Features

Technical Data

Built-in / Free-standing:	Built-in
Door opening:	Drop down
Min. required niche size for installation (HxWxD):	585-595 x 560-568 x 550 mm
Dimensions:	595 x 596 x 548 mm
Dimensions of the packed product (HxWxD): ..	660 x 660 x 690 mm
Control Panel Material:	Glass
Door Material:	Glass
Net weight:	42.3 kg
Length electrical supply cord:	120.0 cm
EAN code:	4242004236047
Fuse protection:	16 A
Voltage:	220-240 V
Frequency:	50; 60 Hz
Plug type:	no plug (electrical connection by electrician)
Number of cavities (2010/30/EC):	1
Usable volume (of cavity) - NEW (2010/30/EC):	71 l
Energy efficiency rating:	A+
Energy consumption per cycle conventional (2010/30/EC): ..	0.87 kWh/cycle
Energy consumption per cycle forced air convection (2010/30/EC):	0.69 kWh/cycle
Energy efficiency index (2010/30/EC):	81.2 %
Included accessories:	1 x grid, 1 x universal pan, 1 x steam container, punched, size S, 1 x steam container, punched, size XL, 1 x steam container, unpunched, size S



Included accessories

1 x grid, 1 x universal pan, punched, size XL, 1 x steam container, unpunched, size S

Optional accessories

Z13CU30X0 Steam container, unpunched, size S, Z13CU31X0 Steam container, punched, size S, Z13CV05S0 Cover Strip, Z13TC10X0 ComfortFlex Rail (1 level) f. steam, Z13TF36X0 3 level telescopic rails, full ext, steam, Z11AB15A0 Baking tray, non-stick ceramic coated, Z11AU15A0 Universal pan, non-stick ceramic coated, Z11CG10X0 Barbecue-Set, Z11GT10X3 Glass roasting dish, 5,4l, Z11GU20X0 Glasspan, Z11SZ00X0 SeamlessCombination mounting kit, Z11SZ80X0 SeamlessCombination 60 + 29cm, Z11SZ90X0 SeamlessCombination 60 + 45cm, Z12CB10A0 Baking tray, enamelled, Z12CL10A0 Lid for professional pan, enamelled, Z12CM10A0 Moussaka pan, enamelled, Z12CN10A0 Professional pan, enamelled, Z12CP10A0 Pizza pan, enamelled, Z12CQ10A0 Grill tray, enamelled, Z12CU10A0 Multipurpose pan, enamelled, Z13CR10X0 Baking and roasting grid (steam)

N 90, BUILT-IN OVEN WITH STEAM FUNCTION, 60
X 60 CM, STAINLESS STEEL
B47FS34H0B

Features

Design

- 4.1" TFT colour and graphics display with ShiftControl
- Cavity inner surface: enamel anthracite

- Please refer to the dimensions provided in the installation manual

Features

- HomeConnect ready on WLAN
- Control panel lock
- Automatic safety switch off Residual heat indicator Start button Door contact switch
- Temperature proposal
- Actual temperature display Heating up indicator automatic programmes:
- Baking and roasting assistant, Automatic programmes
- LED light, On/off button
- Water tank empty indicator
- Electronic clock timer

Cleaning

- EcoClean Direct : ceiling, back panel, side liners
- EcoClean programme, Base Clean programme

Programmes/functions

- Additional heating methods with steam: Steaming, Reheat with steam, Dough proving, Defrost
- Additional functions:
- De-scaling programme
- Drying function Automatic boiling point detection
- Number of automatic programmes: 30 PC
- Rapid heat
- Cooling fan

Accessories

- 1-level flexible telescopic rail, full extension, Stop function
- 1 x grid, 1 x universal pan, 1 x steam container, punched, size S, 1 x steam container, punched, size XL, 1 x steam container, unpunched, size S

Performance/technical information

- Energy efficiency rating (acc. EU Nr. 65/2014): A+
- Energy consumption per cycle in conventional mode: 0.87 kWh
- Energy consumption per cycle in fan-forced convection mode: 0.69 kWh
- Number of cavities: Main cavity Heat source: electrical Cavity volume: 71 litre
- 1 l Water tank capacity
- Location of water tank: Outside cavity
- Total connected load electric: 3.45 KW
- Temperature range 40 °C - 250 °C
- 120 cm Cable length
- Nominal voltage: 220 - 240 V
- Appliance dimension (h x w x d): 595 mm x 596 mm x 548 mm
- Niche dimension (h x w x d): 585 mm - 595 mm x 560 mm - 568 mm x 550 mm

N 90, BUILT-IN OVEN WITH STEAM FUNCTION, 60 X 60 CM, STAINLESS STEEL
B47FS34H0B

Dimensioned drawings

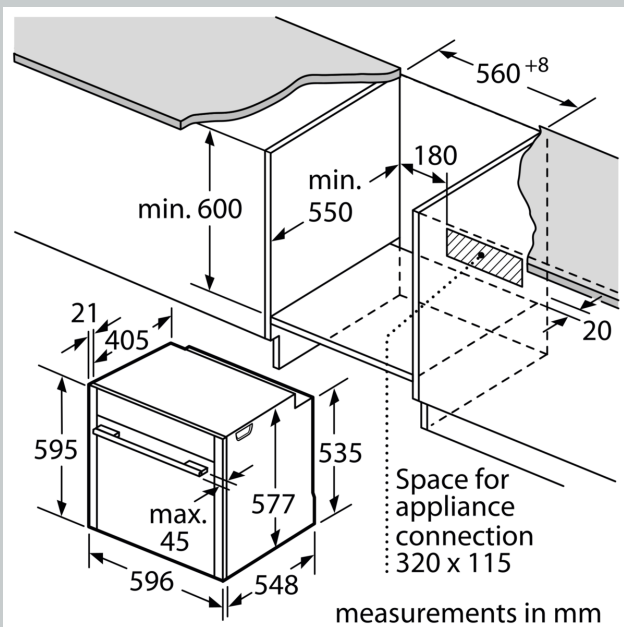
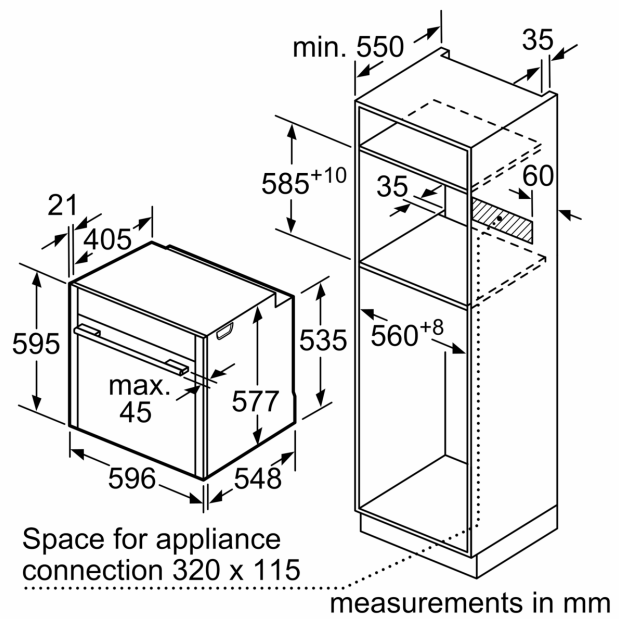
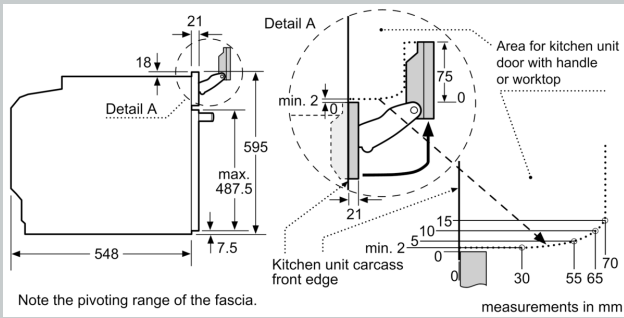

If the appliance will be installed underneath a hob, the following worktop thicknesses (including substructure if necessary) must be taken into account.

Hob type	min. worktop thickness	
	fitted	flush
Induction hob	37 mm	38 mm
Full surface Induction hob	47 mm	48 mm
Gas hob	30 mm	38 mm
Electric hob	27 mm	30 mm