

N 90, BUILT-IN OVEN WITH ADDED STEAM FUNCTION, 60 X 60 CM, STAINLESS STEEL B88VT38NOB



Built-in oven with VarioSteam® and HIDE® - fuller flavour and unrestricted access to the oven interior

- ✓ Slide&Hide® – The fully retracting oven door.
- ✓ CircoTherm® – Smart hot-air solution that lets you bake on up to four levels.
- ✓ Vario Steam – Cooks food moist on the inside and crisp on the outside.
- ✓ Eco Clean with Base Clean - the duo that makes oven cleaning easier
- ✓ Full Touch Control – Simple, precise control by touch on the high-resolution TFT colour display.

Built-in / Free-standing: Built-in
 Integrated Cleaning system: EcoClean programme

Required niche size for installation (HxWxD): 585-595 x 560-568 x 550 mm

Dimensions: 595x596x548 mm

Dimensions of the packed product (HxWxD): . 660 x 660 x 690 mm

Control Panel Material:Stainless steel

Door Material: Glass

Net weight: 42.4 kg

Usable volume of cavity: 71 l

Cooking method: Regeneration, CircoTherm®, Defrost, Bread Baking Setting, Full width grill, Hot Air-Eco, Half width grill, Conventional heat, Conventional heat ECO, Pizza setting, low temperature cooking, Bottom heat, Hot air grilling, pre-heating, warming

Oven control: electronic

Length electrical supply cord: 120.0 cm

EAN code:4242004214052

Number of cavities (2010/30/EC): 1

Energy efficiency rating: A

Energy consumption per cycle conventional (2010/30/EC): 0.90 kWh/cycle

Energy consumption per cycle forced air convection (2010/30/EC): 0.74 kWh/cycle

Energy efficiency index (2010/30/EC):87.1 %

Connection Rating:3450 W

Fuse protection: 16 A

Voltage: 220-240 V

Frequency: 60; 50 Hz

Plug type: no plug (electrical connection by electrician)

Included accessories:2 x combination grid, 1 x universal pan

2 x combination grid, 1 x universal pan

Z11TC10X0 ComfortFlex Rail (1 level), Z11TF36X0 3 level telescopic rails, full ext, Z99RX70X0 Connecting cable 3m, Z11AB10A0 Baking tray, non-stick coated, Z11AU10A0 Universal pan, non-stick coated, Z11CG10X0 Barbecue-Set, Z11CR10X0 Baking and roasting grid (standard), Z11GT10X3 Glass roasting dish, 5,4l, Z11GU20X0 Glasspan, Z11SZ00X0 SeamlessCombination mounting kit, Z11SZ80X0 SeamlessCombination 60 + 29cm, Z11SZ90X0 SeamlessCombination 60 + 45cm, Z12CP10A0 Pizza pan, enamelled, Z12CQ10A0 Grill tray, enamelled, Z12CU10A0 Multipurpose pan, enamelled, Z13CV05S0 Cover Strip, Z18V60X0 Cookbook, Z1913X0 Baking Stone, Z19DD10X0 Steam set for ovens, Z12CB10A0 Baking tray, enamelled, Z12CL10A0 Lid for professional pan, enamelled, Z12CM10A0 Moussaka pan, enamelled, Z12CN10A0 Professional pan, enamelled



*N 90, BUILT-IN OVEN WITH ADDED STEAM
FUNCTION, 60 X 60 CM, STAINLESS STEEL
B88VT38NOB*

Special features

- 5.7" TFT colour and graphics display with FullTouch control
- CircoTherm® Gentle
- Water tank empty indicator
- 1 l Water tank capacity
- LED light, On/off button
- Slide&Hide® with fixed handle, SoftOpen
- MultiPoint MeatProbe
- Temperature proposal
- Actual temperature display Heating up indicator automatic programmes:

Features

- Oven with 14 PC heating methods: CircoTherm®, CircoTherm® Gentle, Top/bottom heat, Conventional heat Gentle, Circo-roasting, Full surface grill, Centre surface grill, CircoTherm® intensive, Bread baking, Bottom heat, Low temperature cooking, Defrost, Plate warming, Keep warm
- Additional heating methods with steam: Reheat with steam, Dough proving
- Control panel lock
- Automatic safety switch off Residual heat indicator Start button Door contact switch
- Electronic clock timer
- Full glass inner door
- Triple glazed door
- Additional functions:
- De-scaling programme
- Drying function steam cooking function
- Number of automatic programmes: 14 PC
- Baking and roasting assistant, Automatic programmes
- Rapid heat
- Cooling fan
- Stainless-steel fan
- Info button

Design

- TFT display
- Touch control
- Fully Integrated handle
- Cavity inner surface: enamel anthracite

Cleaning

- EcoClean programme, Base Clean programme
- De-scaling programme

Standard accessories

- 1-level flexible telescopic rail, full extension, Stop function

Accessories

- 2 x combination grid, 1 x universal pan

Technical information

- Cavity volume: 71 litre
- Location of water tank: Outside cavity
- Temperature range 40 °C - 275 °C
- 120 cm Cable length
- Total connected load electric: 3.45 KW
- Appliance dimension (hxwx): 595 mm x 596 mm x 548 mm
- Niche dimension (hxwx): 585 mm - 595 mm x 560 mm - 568 mm x 550 mm
- Please refer to the dimensions provided in the installation manual
- Energy efficiency rating (acc. EU Nr. 65/2014): A
- Energy consumption per cycle in conventional mode: 87.1
- Energy consumption per cycle in fan-forced convection mode: 0.74 kwh
- Number of cavities: 1 Cavity volume: 71 litre

N 90, BUILT-IN OVEN WITH ADDED STEAM
FUNCTION, 60 X 60 CM, STAINLESS STEEL
B88VT38NOB

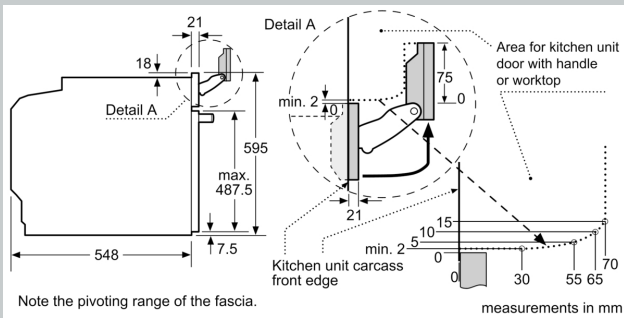

If the appliance will be installed underneath a hob, the following worktop thicknesses (including substructure if necessary) must be taken into account.

Hob type	min. worktop thickness	
	fitted	flush
Induction hob	37 mm	38 mm
Full surface Induction hob	47 mm	48 mm
Gas hob	30 mm	38 mm
Electric hob	27 mm	30 mm

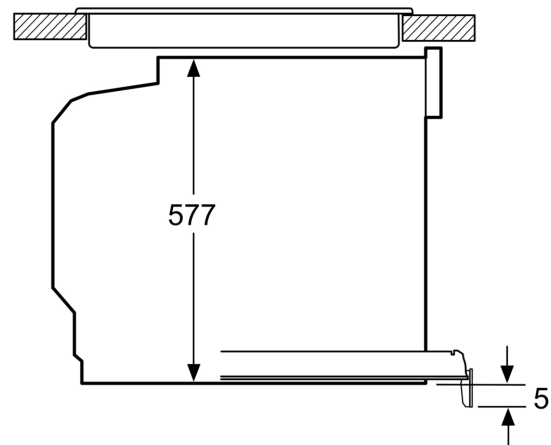
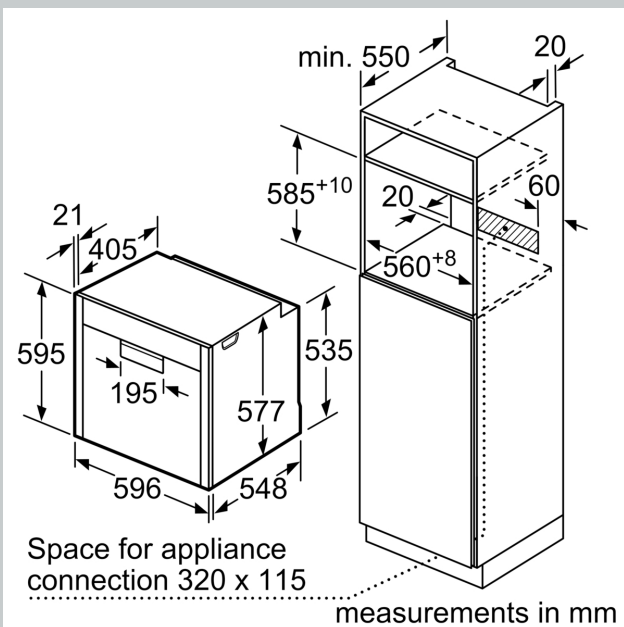

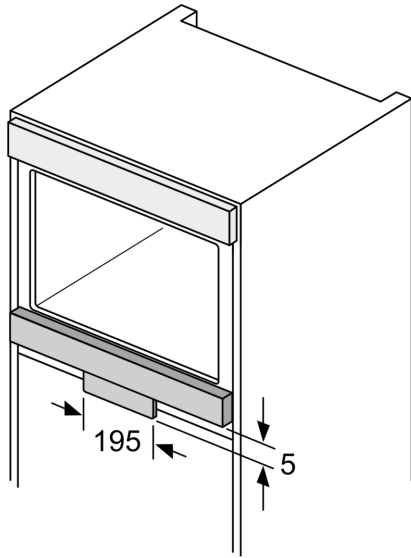

measurements in mm

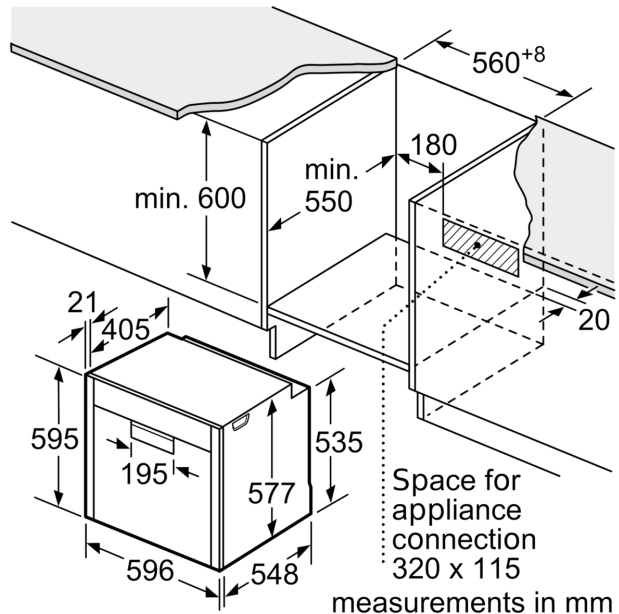

measurements in mm