

N 90, BUILT-IN COMPACT OVEN WITH
MICROWAVE FUNCTION, 60 X 45 CM, STAINLESS
STEEL
C17MS32H0B

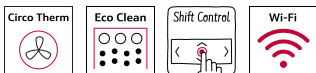

Included accessories

1 x combination grid, 1 x universal pan

Optional accessories

Z11AB15A0 Baking tray, non-stick ceramic coated, Z11AU15A0
Universal pan, non-stick ceramic coated, Z11GT10X3 Glass
roasting dish, 5,4l, Z11GU20X0 Glasspan, Z11SZ00X0
SeamlessCombination mounting kit, Z11SZ60X0
SeamlessCombination 45 + 14cm, Z11SZ90X0
SeamlessCombination 60 + 45cm, Z12CB10A0 Baking tray,
enamelled, Z12CM10A0 Moussaka pan, enamelled, Z12CP10A0
Pizza pan, enamelled, Z12CQ10A0 Grill tray, enamelled,
Z12CU10A0 Multipurpose pan, enamelled, Z13CR10X0 Baking and
roasting grid (steam), Z13CV05S0 Cover Strip, Z13CV06S0 Decor
strip, Z14CR10X0 Baking and roasting grid (microwave), Z1913X0
Baking Stone, Z19DD10X0 Steam set for ovens

Compact built-in oven with integral microwave - even more ways
to cook quickly and conveniently in a very small space

- ✓ CircoTherm® – Smart hot-air solution that lets you bake on up to four levels.
- ✓ Combined microwave and oven - the convenient solution to save space and time
- ✓ Eco Clean with Base Clean - the duo that makes oven cleaning easier
- ✓ Shift Control - fast navigation through menus and simple operation with the TFT display.
- ✓ Home Connect – Unleash your creativity via app.

Features

Technical Data

Type of micro-wave oven: MW-Combi
Type of control: Electronic
Dimensions: 455 x 596 x 548 mm
Cavity dimensions: 237.0 x 480 x 392.0 mm
Length electrical supply cord: 150.0 cm
Net weight: 34.4 kg
Gross weight: 36.7 kg
EAN code: 4242004236306
Maximum micro-wave power: 900 W
Connection Rating: 3600 W
Fuse protection: 16 A
Voltage: 220-240 V
Frequency: 50; 60 Hz
Plug type: no plug
(electrical connection by electrician)
Included accessories: 1 x combination grid, 1 x universal pan



N 90, BUILT-IN COMPACT OVEN WITH
MICROWAVE FUNCTION, 60 X 45 CM, STAINLESS
STEEL
C17MS32H0B

Features

Design

- 4.1" TFT colour and graphics display with ShiftControl
- Cavity inner surface: enamel anthracite
- Drop down door, SoftClose, soft opening
- Illuminated Shift Control
- Bar handle
- We recommend you to choose complementary products within N90, in order to assure an optimal design combination of your Built-In appliances.

- Nominal voltage: 220 - 240 V
- Appliance dimension (hxwxh): 455 mm x 596 mm x 548 mm
- Niche dimension (hxwxh): 450 mm - 455 mm x 560 mm - 568 mm x 550 mm
- Please refer to the dimensions provided in the installation manual

Features

- HomeConnect ready on WLAN
- Control panel lock
- Automatic safety switch off Residual heat indicator Start button Door contact switch
- Temperature proposal
- Actual temperature display Heating up indicator automatic programmes:
- Baking and roasting assistant, Automatic programmes
- Intelligent microwave inverter technology: For optimised results maximum output power will be regulated to 600 W when used in longer operation for gentler cooking.
- LED light, On/off button
- Cooling fan
- Electronic clock timer
- 3 shelf positions

Cleaning

- EcoClean Direct : ceiling, back panel, side liners
- EcoClean programme, Base Clean programme

Programmes/functions

- Compact oven with microwave with 12 main functions heating methods: CircoTherm®, CircoTherm® Gentle, Top/bottom heat, Conventional heat Gentle, Circo-roasting, Full surface grill, Centre surface grill, CircoTherm® intensive, Bottom heat, Low temperature cooking, Dough proving, Plate warming
- Additional heating methods with microwave: Microwave, Microwave combination cooking
- Max. Power: 900 W; 5 Microwave power settings (90 W, 180 W, 360 W, 600 W, 900 W)
- Number of automatic programmes: 14 PC
- Rapid heat

Accessories

- 1 x combination grid, 1 x universal pan

Performance/technical information

- Cavity volume: 45 litre
- Temperature range 30 °C - 275 °C
- Power cord length 150 cm Cable length
- Total connected load electric: 3.6 KW

N 90, BUILT-IN COMPACT OVEN WITH MICROWAVE FUNCTION, 60 X 45 CM, STAINLESS STEEL
C17MS32H0B

Dimensioned drawings

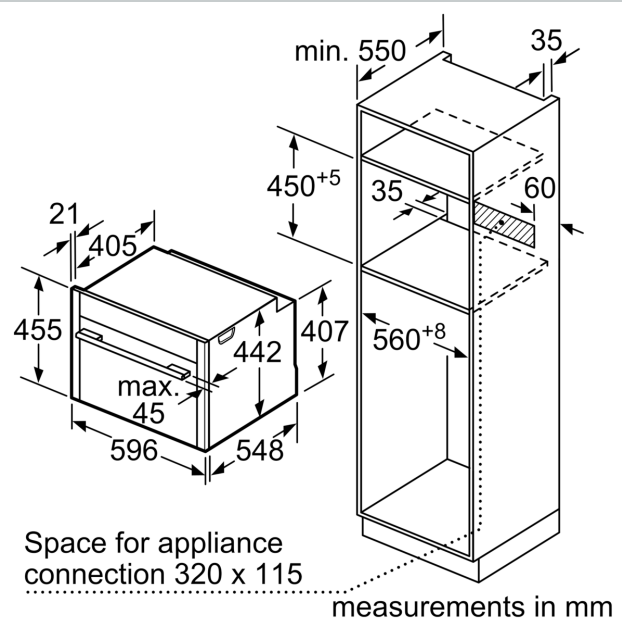
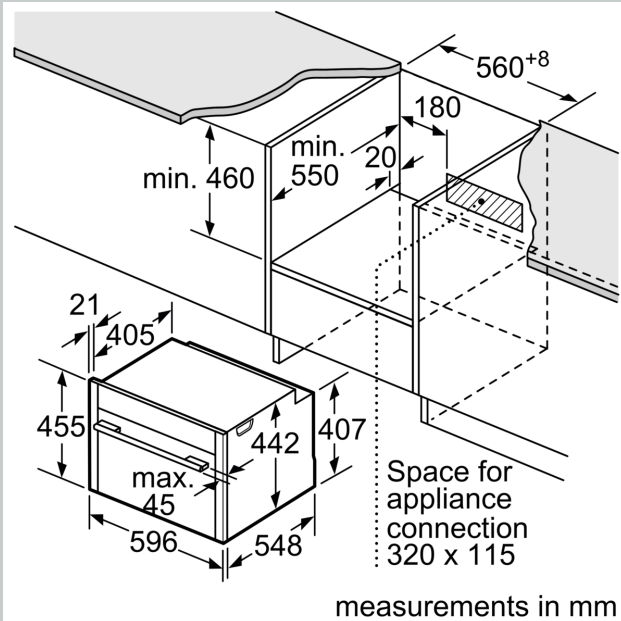

Installation with a hob.

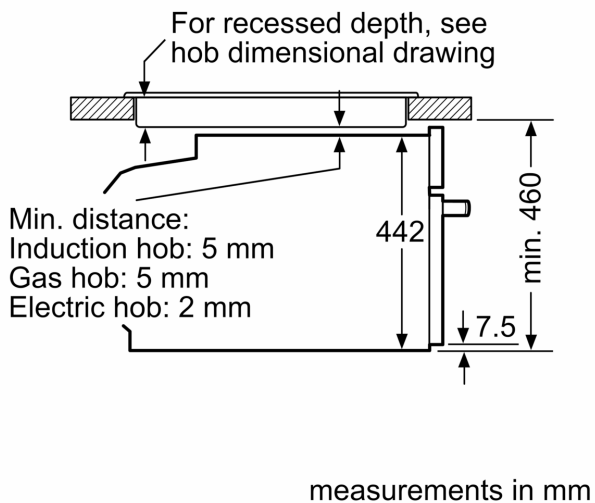

If the compact appliance will be installed underneath a hob, the following worktop thicknesses (including substructure if necessary) must be taken into account.

Hob type	min. worktop thickness	
	fitted	flush
Induction hob	42 mm	43 mm
Full surface Induction hob	52 mm	53 mm
Gas hob	32 mm	43 mm
Electric hob	32 mm	35 mm