

N 50, INTEGRATED DESIGN HOOD, 60 CM, CLEAR  
GLASS, MATT BLACK  
D65XCC2S0B



- ✓ Extra Space Storage: The hood's T-shaped design creates extra space for items up to 10kg each side.
- ✓ Energy-efficient Capacitor Motor: a convenient cooking experience with a powerful suction.
- ✓ Push Button Control: Easy and convenient control of hood settings.
- ✓ LED Lighting – Clear illumination while you cook.
- ✓ Seamless Integration: Almost invisible in an upper cabinet thanks to flush mounted installation.

Optional accessories

Z51IB1X6	Long-life Clean Air recirculation kit
Z51IBK1S2	Chimney extension 450-854 mm
Z51IBN1S2	Chimney extension 187-360 mm

Features

Technical Data

Typology:	Built-in/Built-under
Length electrical supply cord:	130 cm
Required niche size for installation (HxWxD):	340mm x 560.0mm x 300mm mm
Height of the appliance:	60 mm
Minimum distance above an electric hob:	430 mm
Minimum distance above a gas hob:	650 mm
Net weight:	7.7 kg
Type of control:	Mechanical
Number of speed settings:	3
Maximum output air extraction:	582 m <sup>3</sup> /h
Maximum output recirculating air:	521 m <sup>3</sup> /h
Maximum Air flow:	582 m <sup>3</sup> /h
Number of lights:	2
Noise level:	65 dB(A) re 1pW
Diameter of air outlet:	150 mm
Grease filter material:	Washable stainless steel
EAN code:	4242004287896
Connection Rating:	200 W
Voltage:	220-240 V
Frequency:	50; 60 Hz
Plug type:	GB plug
Installation typology:	Built-in



N 50, INTEGRATED DESIGN HOOD, 60 CM, CLEAR  
GLASS, MATT BLACK  
D65XCC2S0B

## Features

### Design:

- Installation in a wall cupboard
- Flush-fitted installation for a seamless integration in wall cupboards.
- Glass panel: clear glass
- Enlarged storage space: max. 10 kg capacity on each hood side
- Suitable for ducted extraction and recirculation

### Core Features:

- Capacitor energy efficient
- 2 x LED 1.5W
- Colour Temperature: 3500 K
- Light Intensity: 316 lux
- 2 metal grease filter(s).

### Comfort Features:

- Adjustable glass visor for additional vapour capture
- Cupboard protection: additional side and rear protection against vapour
- Push button control operation for extractor speeds and light
- 3 power levels

### Cleaning Comfort:

- Easy to clean smooth surfaces and materials.
- metal grease filter dishwasher-safe
- Coated surfaces for less fingerprint sensitivity

### Exhaust Mode:

- According to EN 61591 and EN/ IEC 60704-2-13 your appliance can achieve the following values in exhaust mode:
- Speed 1: extraction rate 349 m<sup>3</sup>/h; noise level 54 dB(A) re1pW
- Speed 2: extraction rate 458 m<sup>3</sup>/h; noise level 60 dB(A) re1pW
- Speed 3: extraction rate 583 m<sup>3</sup>/h; noise level 65 dB (A) re1pW
- Energy Efficiency Class: B (at a range of energy efficiency classes from A+++ to D)
- Average Energy Consumption: 70.5 kWh/year\*
- Blower Efficiency Class: B\*
- Lighting Efficiency Class: A\*
- Grease Filtering Efficiency Class: B\*

### Recirculation Mode:

- For recirculation operation Long-life Clean Air recirculation kit (accessory) needed
- The Long-life Clean Air odour filter absorbs intense odours, such as fish, as well as pollen. The lifetime can be extended up to 4 times by refreshing the filter in the oven
- According to EN 61591 and EN/ IEC 60704-2-13 your appliance can achieve the following values in recirculation mode with Long-life Clean Air recirculation kit (available as optional accessory):
- Speed 1: extraction rate 333 m<sup>3</sup>/h; noise level 61 dB(A) re1pW
- Speed 2: extraction rate 441 m<sup>3</sup>/h; noise level 68 dB(A) re1pW
- Speed 3: extraction rate 521 m<sup>3</sup>/h; noise level 72 dB (A) re1pW

### Technical Information and Sustainability:

- Consumption data:
- Power rating: 200 W
- Voltage: Nominal voltage: 220 - 240 V
- Sustainability:
- Made in Germany: produced at a CO2 neutral production site
- Environmentally friendly packaging
- Available Long-life Clean Air odour filter with extended lifetime up to 4 times

### Planning and Installation Information:

- Installation: Cupboard 60 cm
- Installation system: IDH comfort installation
- Appliance dimensions (HxWxD): 340 x 598 x 298 mm
- Built-in dimensions (HxWxD): min. 340 mm x 560 mm x min. 300 mm
- Enclosed spacers for installation in wall cupboards with maximum depth of up to 360mm.
- For installation in higher wall cupboards chimney extensions are available as optional accessories.
- Diameter pipe Ø 150 mm
- Electrical cable length 1.3 m

N 50, INTEGRATED DESIGN HOOD, 60 CM, CLEAR  
GLASS, MATT BLACK  
D65XCC2S0B

Dimensioned drawings

Measurements in mm  
**Front view**

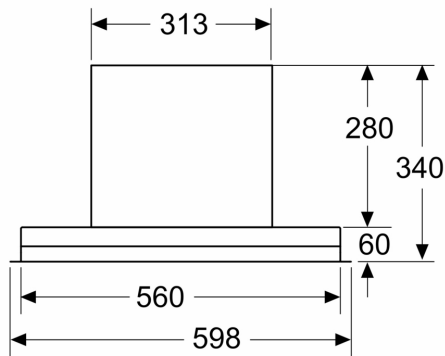

Measurements in mm  
**Installation example**

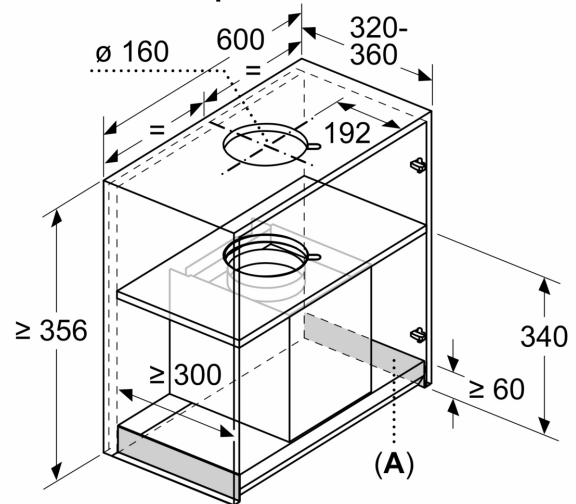

**A:** Area without hinges

Measurements in mm  
**View from above**

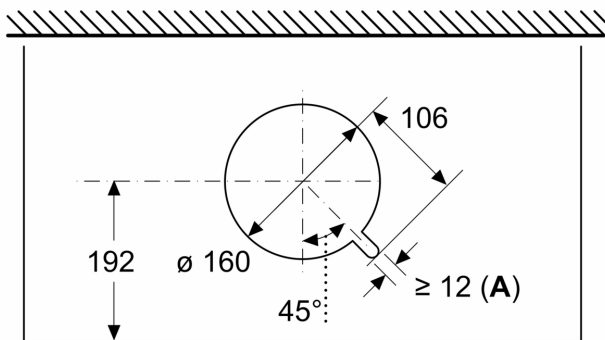

**A:** Cable bushing

Measurements in mm

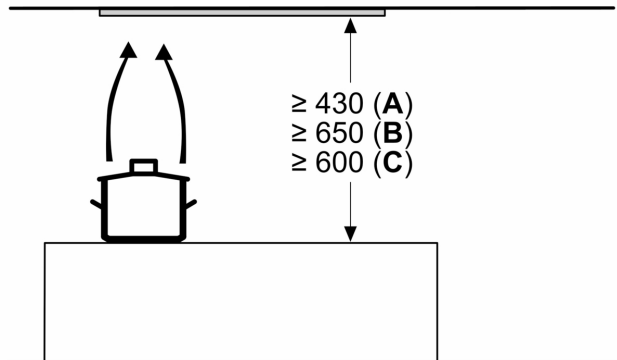

**A:** Electric

**B:** Gas - from upper edge of pan support

**C:** Electric - for Australia and New Zealand

## Dimensioned drawings

Measurements in mm  
Installation example with spice rack

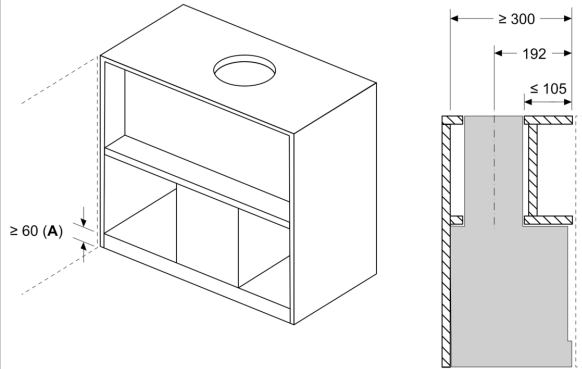

A: Area without hinges

Installation example in cupboards with crossbar, if installation with chimney extension (other accessories) not possible

Measurements in mm  
Installation example in furniture cut-out

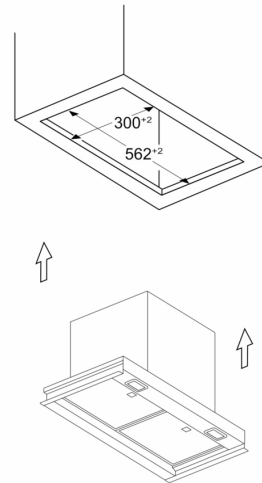

Measurements in mm  
Installation requirements for replacement business

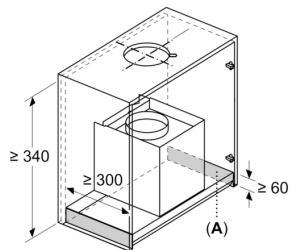

A: Area without hinges

Installation requirements for replacing existing built-in hood solutions with integrated design hood without replacing the cupboard

Measurements in mm  
Side view

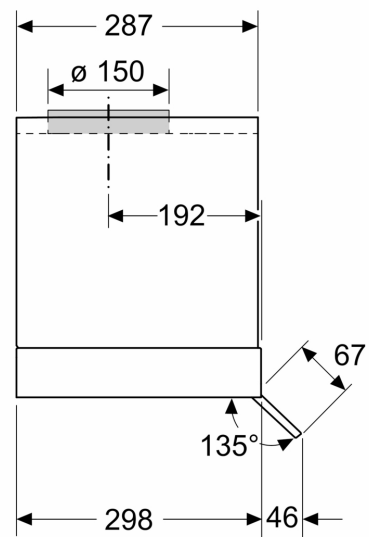

Dimensioned drawings

Measurements in mm

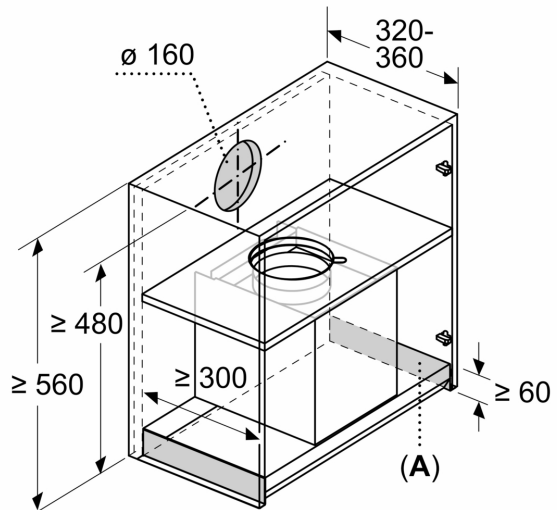

**A:** Area without hinges