

N 30, WALL-MOUNTED COOKER HOOD, 90 CM,
STAINLESS STEEL
D92PBCON0B



The pyramid hood is a traditionally designed hood and a trademark design of our collections.

√ LED Lighting – Clear illumination while you cook.

Z5138X1	Standard odor filter (replacement)
Z5138X5	Standard recirculation kit
Z5861N0	Back panel stainless steel
Z5895N0	Stainless steel back panel 900 mm
Z5904N0	Chimney extension 500 mm
Z5904N5	Chimney extension 750 mm

Typology:	Wall-mounted
Length electrical supply cord:	130.0 cm
Height of the chimney:	553-730/573-730 mm
Height of the appliance:	246 mm
Minimum distance above an electric hob:	550 mm
Minimum distance above a gas hob:	650 mm
Net weight:	8.8 kg
Type of control:	mechanical
Number of speed settings:	3
Maximum output air extraction:	365 m ³ /h
Maximum output recirculating air:	213 m ³ /h
Maximum Air flow:	365 m ³ /h
Number of lights:	2
Noise level:	65 dB(A) re 1pW
Diameter of air outlet:	120 / 150 mm
Grease filter material:	Washable aluminium
EAN code:	4242004221531
Connection Rating:	100 W
Fuse protection:	10 A
Voltage:	220-240 V
Frequency:	50; 60 Hz
Plug type:	GB plug
Installation typology:	Wall-mounted



N 30, WALL-MOUNTED COOKER HOOD, 90 CM,
STAINLESS STEEL
D92PBCNOB

Key performance features:

- Energy Efficiency Class: D (at a range of energy efficiency classes from A+++ to D)
- Max. extraction rate: 365 m³/h
- Noise max. Normal Level: Noise, max. speed in normal us: 65 dB dB*

Features

- Push button control operation
- 3 power levels
- 2 x 1.5w LED Light
- Colour Temperature: 3500 K
- 3 metal grease filter cassettes
- Installation: wall

Design

- Chimney hood
- Mechanical controls

Performance/technical information

- Suitable for ducted extraction and recirculation
- For recirculated extraction recirculating kit (accessory) needed
- Maximum extraction rate exhaust air 365 m³/h according to EN 61591
- Extraction rate in recirculation mode:
 - Max. normal use: 213 m³/h
- Noise level according to EN 60704-3 and EN 60704-2-13 at max. normal use exhaust air: 65 dB(A) re 1 pW
- Noise level in recirculation mode:
 - Max. normal use: 67 dB(A) re 1 pW (54 dB(A) re 20 µPa sound pressure)
- Power rating: 100 W
- Light Intensity: 94 lux
- Electrical cable length 1.3 m
- Diameter pipe Ø 150 mm (Ø 120 mm enclosed)
- Dimensions exhaust air (HxWxD): 799-975 x 900 x 500 mm
- Dimensions recirculating (HxWxD): 799-975 x 900 x 500 mm
- Blower Efficiency Class: E*
- Lighting Efficiency Class: A*
- Grease Filtering Efficiency Class: D*
- Average Energy Consumption: 53.1 kWh/year*

Optional accessories

- Recirculating kit Z5138X1

* In accordance with the EU-Regulation No 65/2014

N 30, WALL-MOUNTED COOKER HOOD, 90 CM,
STAINLESS STEEL
D92PBCONOB

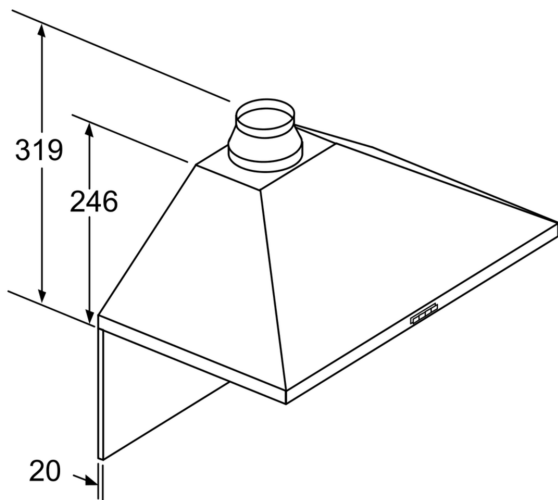

If a back panel is used,
the design of the appliance
must be considered.

measurements in mm

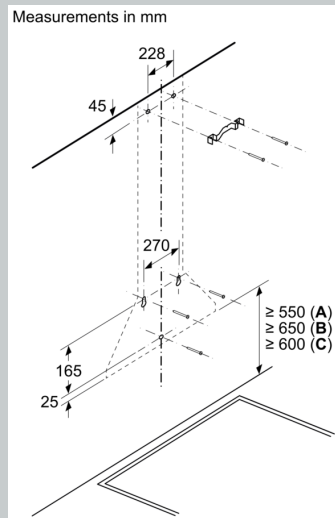

A: Electric

B: Gas - from upper edge of pan support

C: Electric - for Australia and New Zealand

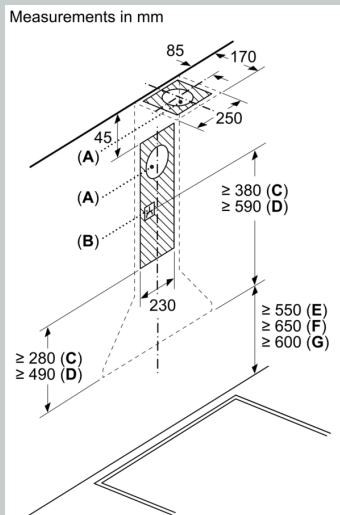

- A: Exhaust-air outlet
- B: Socket
- C: Exhaust air
- D: Circulated air
- E: Electric
- F: Gas - from upper edge of pan support
- G: Electric - for Australia and New Zealand

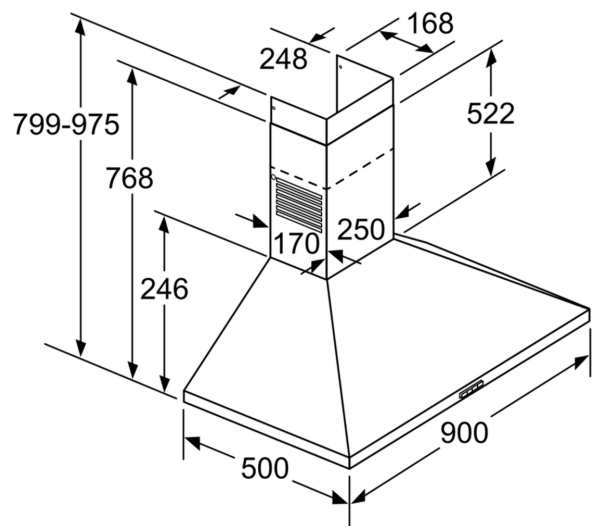

measurements in mm