

N 90, DOWNDRAFT HOOD, 80 CM, FLEX DESIGN
188WMM1Y7B



The Glass Draft Hood seamlessly integrates into the kitchen, with ability to install behind the hob for a single surface look and clear glass panel when in use. Powered by new Guided Air Technology for effective extraction, and Climate Control Sensor to optimise the power and noise levels as you cook.

- ✓ Guided Air Technology – Equally powerful steam extraction all over the cooktop regardless of the pans' or pots' location
- ✓ Glass Panel with Illumination – 25 million colour options for inspiring illumination of your cooktop
- ✓ Easy Access Filter – A simple push of a button is enough to remove the easy access filter for a good wash in the dishwasher
- ✓ High Extraction Rate – ensures a clear view while cooking thanks to an efficient motor technology
- ✓ Cooktop-based Hood Control – Adjust your hood's extraction level and lighting.



Optional accessories

Z5802GLAY0 Flex Design trims glassdraft A.Grey, Z5802GLBY0 Flex Design trims glassdraft B.Bronze, Z5802GLDY0 Flex Design trims glassdraft D.Black, Z5802GLMY0 Flex Design trims glassdraft M.Silver, Z861SB1 90° flat duct bend horizontal, Z861SB2 90° flat duct L vertical, Z861S10 Adapter round-flat, Z861S11 90° Adapter round-flat, Z861SM1 Straight tube 500mm, Z861SM2 Straight tube 1000mm, Z861SS1 Connector sleeve (female), Z92WWB1X6 Clean Air Plus odor filter (replacement), Z92WWI1X6 Clean Air Plus recirculation kit, Z92WWJ11 Long Life recirculation kit, Z92WWM11 Installation kit remote motor, Z92WWY8X2 Mounting kit for seamless installation, Z9302GLAY0 Flex Design seaml. glassdr+hob A.Grey, Z9302GLBY0 Flex Design seaml. glassdr+hob B.Bronze, Z9302GLDY0 Flex Design seaml. glassdr+hob D.Black, Z9302GLMY0 Flex Design seaml. glassdr+hob M.Silver, Z93WWX1X1 Flat duct adapt.round 90° DN150 Metal, Z93XXX1X1 Aluflex pipe cyl. 150

installation accessories

Z5802GLAY0 Flex Design trims glassdraft A.Grey
 Z5802GLBY0 Flex Design trims glassdraft B.Bronze
 Z5802GLDY0 Flex Design trims glassdraft D.Black
 Z5802GLMY0 Flex Design trims glassdraft M.Silver
 Z9302GLAY0 Flex Design seaml. glassdr+hob A.Grey
 Z9302GLBY0 Flex Design seaml. glassdr+hob B.Bronze
 Z9302GLDY0 Flex Design seaml. glassdr+hob D.Black
 Z9302GLMY0 Flex Design seaml. glassdr+hob M.Silver

Features

Technical Data

Typology: Downdraft
 Length electrical supply cord: 130 cm
 Required niche size for installation (HxWxD): 703mm x 781.0mm x 123mm mm
 Height of the appliance: 709 mm
 Net weight: 38.9 kg
 Type of control: Electronic
 Number of speed settings: 3-stage + 2 intensive
 Maximum output air extraction: 501 m³/h
 Boost position output recirculating: 525 m³/h
 Maximum output recirculating air: 416 m³/h
 Boost position air extraction: 775 m³/h
 Maximum Air flow: 501 m³/h
 Noise level: 62 dB(A) re 1pW
 Diameter of air outlet: 150 mm
 Grease filter material: Washable stainless steel
 EAN code: 4242004270782
 Connection Rating: 300 W
 Fuse protection: 10 A
 Voltage: 220-240 V
 Frequency: 50-60 Hz
 Plug type: GB plug
 Installation typology: Built-in



N 90, DOWNDRAFT HOOD, 80 CM, FLEX DESIGN 188WMM1Y7B

Features

Variant

- 80 cm wide
- Installation: integrated
- Suitable for ducted extraction and recirculation

Design

- Extendable clear glass panel with edge lighting
- edges illuminated
- Flex design: Exchangeable side trims, available in various colours and lengths (not included in the standard delivery)
- Pure surface design: suitable for seamless installation to create a unity look with the cooktop (special accessories required)

Comfort

- Touch control
- The standard functions are located on the right-hand user interface
- Touch control for extractor speeds and light
- 3 power levels and 2 intensive settings
- Automatic revert setting
- Automatic intensive revert (6mins)
- Automatic after running (Automatic after running (10 minutes))
- climateControl Sensor
- Hob-Hood control (with Wi-Fi enabled hob)
- Fully automatic hood

Features

- Additional functions: Ambient light RGB
- 2 metal grease filter cassettes
- Saturation indicator for metal and charcoal filter
- The filter service button automatically lifts filters into service position for easy removal
- The glass panel can be easily removed and cleaned

Connectivity

- Remote Monitoring and Control for connected home appliances and operation via smartphone or tablet (only in countries where Home Connect service is available)
- The Home Connect functionality can be extended by integrating numerous applications from external cooperation partners (partnerships)
- Voice Control enabled via popular voice assistants (only in countries where this service is available)
- Silence function: available via Home Connect
- Interval function: available via Home Connect

Performance

- Extraction rate according to EN 61591 ø 15 cm:
 - max. Normal use 501m³/h
 - Intensive 775 m³/h
- Noise level according to EN 60704-3 and EN 60704-2-13 exhaust air:
 - Max. normal use: 62dB(A) re 1 pW
 - Intensive: 70 dB(A) re 1 pW
- With the Clean Air Plus recirculation kit (available as optional

accessory) your appliances reaches:

- Extraction rate in recirculation mode:
 - Max. normal use: 416m³/h
 - Intensive: 525m³/h
- Noise level in recirculation mode:
 - Max. normal use: 65dB(A) re 1 pW
 - Intensive: 70 dB(A) re 1 pW
- Efficient BLDC technology

Planning and installation information

- Suitable for installation in an island or Semi-island kitchen solution
- Suitable for installation into 90 cm cabinet
- Not suitable for combination with gas hobs
- Please reference the built-in dimensions provided in the installation drawings
- For recirculated extraction Clean Air Plus recirculation kit (accessory) needed
- For remote motor installation, special accessory kit (Z92WWM11) is needed
- Built-in dimensions (HxWxD): 703 x 781 x 123 mm
- Dimensions (HxWxD): 709 x 802 x 140 mm
- Extension height 250 mm
- Extractor hose 150 mm
- Electrical cable length 1.3 m

Consumption Data

- Energy Efficiency Class: A (at a range of energy efficiency classes from A+++ to D)
- Average Energy Consumption: 36.9 kWh/year*
- Blower Efficiency Class: A*
- Lighting Efficiency Class: -*
- Grease Filtering Efficiency Class: B*
- Power rating: 300 W

N 90, DOWNDRAFT HOOD, 80 CM, FLEX DESIGN
188WMM1Y7B

Dimensioned drawings

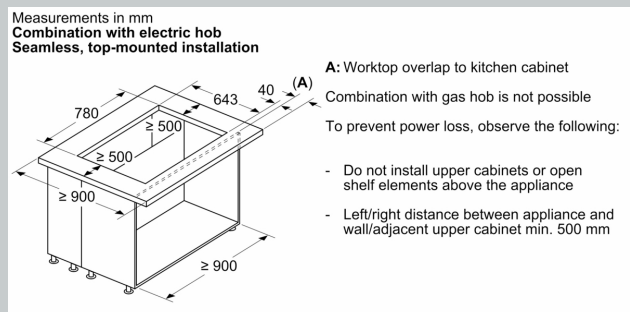
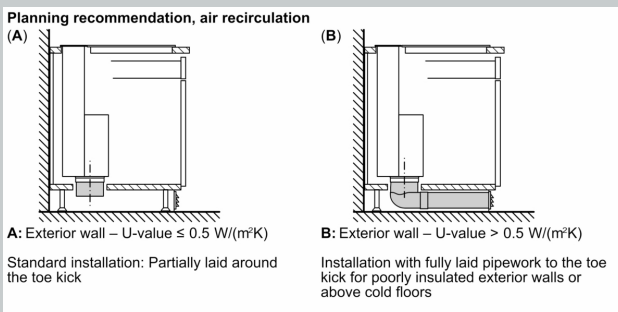
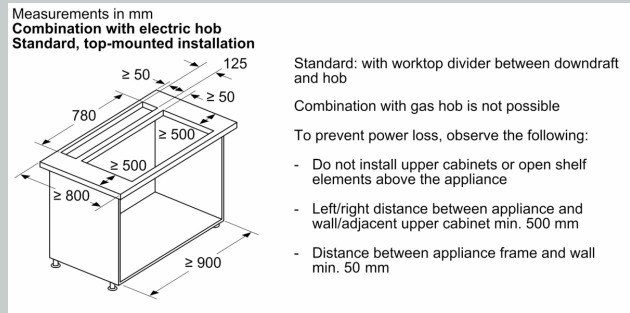
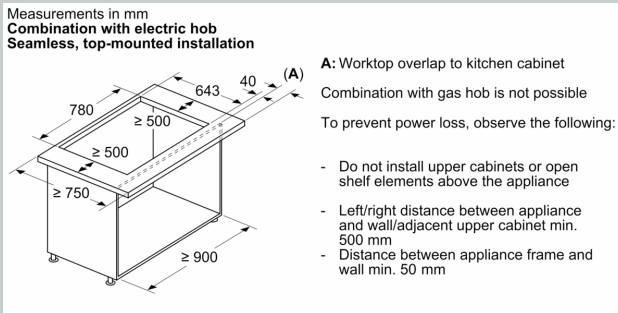
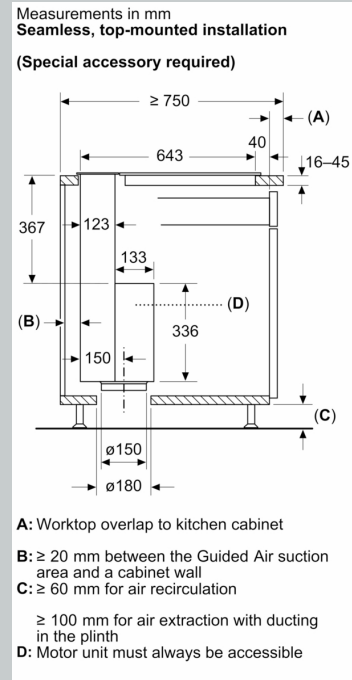
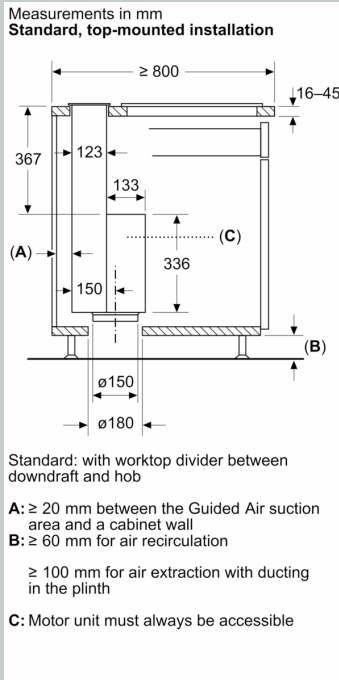

Dimensioned drawings

Measurements in mm
Combination with electric hob
Standard, top-mounted installation

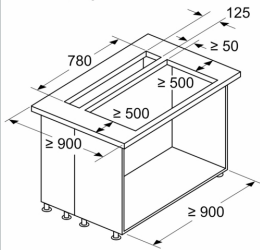

Standard: with worktop divider between downdraft and hob

Combination with gas hob is not possible

To prevent power loss, observe the following:

- Do not install upper cabinets or open shelf elements above the appliance
- Left/right distance between appliance and wall/adjacent upper cabinet min. 500 mm

Measurements in mm

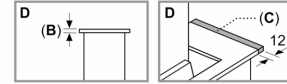
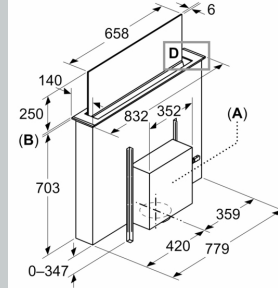

A: Installation of motor unit on front/rear or offset laterally with max. 3 m clearance (special accessory required)

Motor unit must always be accessible

B: 5.5 mm

C: Special accessory required