

N 70, Ceiling cooker hood, 90 cm, Stainless steel
199C68N1GB

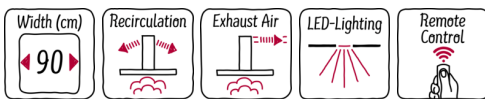

A



Optional accessories

Z5170X1	CleanAir active carbon filter spare part
Z5190X0	CleanAir Recirculation module

Flush with the ceiling, the stylish integrated ceiling hood leaves room for an open and clear kitchen

- ✓ Remote Control – comfortably control the ceiling hood with a remote
- ✓ Intensive speed setting: increases the extraction rate when the steam gets intense
- ✓ Interval Ventilation – automatically ventilates every hour for crisp, clean air

Features

Technical Data

Typology : Traditional
 Approval certificates : CE, NEMKO
 Length of electrical supply cord (cm) : 130
 Required niche size for installation (HxWxD) : 299mm x 870.0mm x 476mm
 Minimum distance above an electric hob : 550
 Minimum distance above a gas hob : 650
 Net weight (kg) : 15.300
 Type of control : Electronic
 Maximum output air extraction (m³/h) : 583
 Boost position output recirculating (m³/h) : 570.0
 Boost position air extraction (m³/h) : 780
 Number of lights (Stck) : 4
 Noise level (dB(A) re 1 pW) : 64
 Diameter of air outlet (mm) : 150
 Grease filter material : Washable aluminium
 EAN code : 4242004187905
 Connection rating (W) : 285
 Current (A) : 10
 Voltage (V) : 220-230
 Frequency (Hz) : 50
 Plug type : GB plug
 Installation type : Built-in



4 242004 187905

N 70, Ceiling cooker hood, 90 cm, Stainless steel

199C68M1GB

Features

Features

- For ceiling mounted installation
- 7 segment LED display
- 4 x LED 2.5W
- 3 metal grease filter cassettes
- Stainless steel filter cover, metal grease filter
- Interval operation
- 3 speeds plus intensive
- Automatic revert after 10 minutes.
- Rim ventilation

Design

- Stainless steel
- Stainless steel
- Downdraft
- Ceiling mounted hood
- Soft touch control
- Electronic controls

Performance/technical information

- Suitable for ducted extraction and recirculation
- For recirculated extraction CleanAir recirculating kit (accessory) needed
- Twin channel high performance fan motor
- In recirculation operation chimless use possible
- Extraction rate according to EN 61591 \varnothing 15 cm: max. Normal use 570 m³/h Intensive 780 m³/h
- Power rating: 285 W
- Noise level according to EN 60704-3 and EN 60704-2-13 at maximum normal setting: extraction rate: 64 dB (A) re 1pW
- Noise level according to EN 60704-3 and EN 60704-2-13 exhaust air: Max. normal use: 64 dB(A) re 1 pW Intensive: 71 dB(A) re 1 pW
- Noise max. Normal Level: Noise, max. speed in normal us: 64 dB dB*
- Light Intensity: 673 lux
- Colour Temperature: 4000 K
- Electrical cable length 1.3 m
- Diameter pipe \varnothing 150 mm (\varnothing 150 mm enclosed)
- Dimensions exhaust air (HxWxD): 299-299 x 900 x 500 mm
- Energy Efficiency Class: A (at a range of energy efficiency classes from A+++ to D)
- Blower Efficiency Class: A*
- Lighting Efficiency Class: A*
- Grease Filtering Efficiency Class: E*
- Average Energy Consumption: 58.2 kWh/year*

Optional accessories

- Recirculating kit Z5170X1
- Rotatable motor: possible to position the air outlet on all four sides

* In accordance with the EU-Regulation No 65/2014

N 70, Ceiling cooker hood, 90 cm, Stainless steel
199C68M1GB

Dimensioned drawings

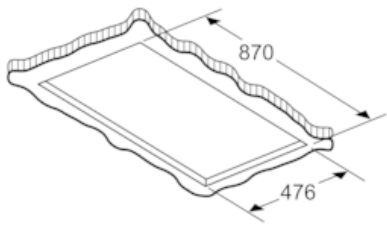

A suitable load-bearing substructure is required for securing the extractor hood. Never fit the appliance directly onto plasterboard or similar lightweight construction materials.

measurements in mm

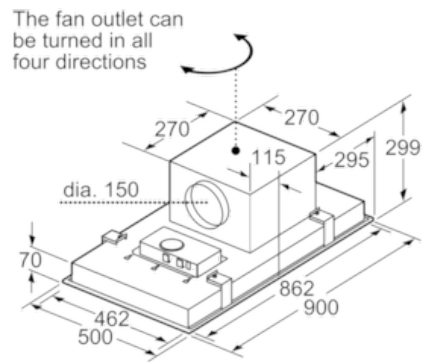

measurements in mm

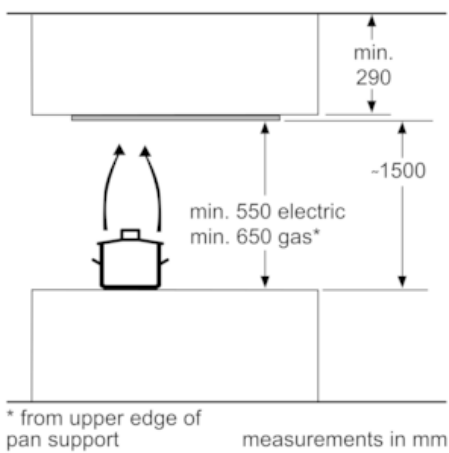

* from upper edge of pan support

measurements in mm