

N 70, BUILT-IN FRIDGE, 140 X 56 CM, FLAT HINGE
K1513FF0



This built-in refrigerator with VarioShelf and many other convenient features keeps foods fresher for longer.

- ✓ Fresh Safe 2 – Ideal storage for fruit and veg.
- ✓ Easy Access Shelf – Slides out for easier access to items in your fridge.
- ✓ Vario Shelf – The glass shelf that can be divided, with one half stored beneath the other, for flexible configurations.
- ✓ Adjustable Glass Shelves – Height adjustable shelves create the space you need for inspiring dishes in your fridge
- ✓ Our safety glass shelves happily shoulder generous loads of delicacies in your fridge

Features

Technical Data

Energy Efficiency Class:F
 Average annual energy consumption in kilowatt hour per year (kWh/a): 133 kWh/a
 Sum of volume of frozen compartments: 0 l
 Sum of volume of chill compartments: 247 l
 Airborne acoustical noise emissions : 33 dB(A) re 1 pW
 Airborne acoustical noise emission class: B
 Construction type: Built-in
 Door panel options: Not possible
 Height: 1397 mm
 Width of the appliance: 558 mm
 Depth of the product: 545 mm
 Min. required niche size for installation (HxWxD): 1400 x 560 x 550 mm
 Net weight: 51.4 kg
 Connection rating: 90 W
 Fuse protection: 10 A
 Door hinge: Right reversible
 Voltage: 220-240 V
 Frequency: 50 Hz
 Length of electrical supply cord: 230.0 cm
 Number of compressors: 1
 Number of independent cooling systems: 1
 Interior ventilator: No
 Reversible Door Hinge: Yes
 Number of Adjustable Shelves in fridge compartment (Stck): 5
 Shelves for Bottles: No
 EAN code: 4242004239048
 Brand: Neff
 Product name / Commercial code: KI1513FF0
 Product category: Refrigerator cabinet
 Frost free system: No
 Installation type: Full-integrated
 Included accessories: 2 x egg tray

Included accessories

2 x egg tray

Optional accessories

KSGG0MZ0 Butter box
 KS10Z020 Bottle Rack
 KS9E0FZ0 Package Neff FlexCooling



N 70, BUILT-IN FRIDGE, 140 X 56 CM, FLAT HINGE K11513FF0

Features

- Fully integrated

Functions

- Fixed hinge
- Bright interior LED fridge light

Design features

- LED Electronic control
- Super Cooling: automatic deactivation
- Automatic defrost fridge
- Acoustic door open warning indicator

Design features

- 6 removable safety glass shelves of which 5 are easy pull out
- 1 dairy compartment in door
- 5 door bins,
- 1 extra deep with divider
- 3 Small door bins

Freshness System

- 1 FreshSafe 2 drawer; High humidity retains nutrients up to twice as long

Key features - Fridge section

- Right hinged door, reversible
- Connection value 90 W
- 220 - 240 V

Dimension and installation

- Dimensions: 139.7 cm H x 55.8 cm W x 54.5 cm D
- Niche Dimensions: 140 cm H x 56 cm W x 55 cm D

Key features - Freezer section

- 2 x egg tray

Design features

Country Specific Options

- Based on the results of the standard 24-hour test. Actual consumption depends on usage/position of the appliance.

Dimension and installation

Performance and Consumption

- EU19_EEK_D: F
- Total Volume : 247 l
- Net Fridge Volume : 247 l
- Net Freezer Volume : 0 l
- Annual Energy Consumption: 133 kWh/a
- Climate Class: SN-ST
- EU19_Fast freezer facility_D
- Noise Level : 33 dB , EU19_Noise emission class_D: B
- BottleFlex Shelf

N 70, BUILT-IN FRIDGE, 140 X 56 CM, FLAT HINGE
K1513FF0

Dimensioned drawings

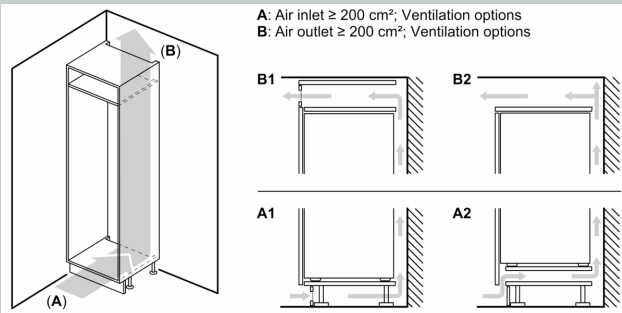

Maximal permissible weight of the unit fronts

Fitted unit fronts that exceed the permissible weight may cause damage and result in functional impairment of the hinges

Δ Weight
A: Appliance door height including hinges in mm

B: Undamped hinge, unit front in kg
C: Damped hinge, unit front in kg

D: Additional possible load in kg with heavy load kit

A	B	C	D
1500-1750	22	22	
720-1400	19	19	B+5 / C+5
A1	15	19	
A2	15	19	

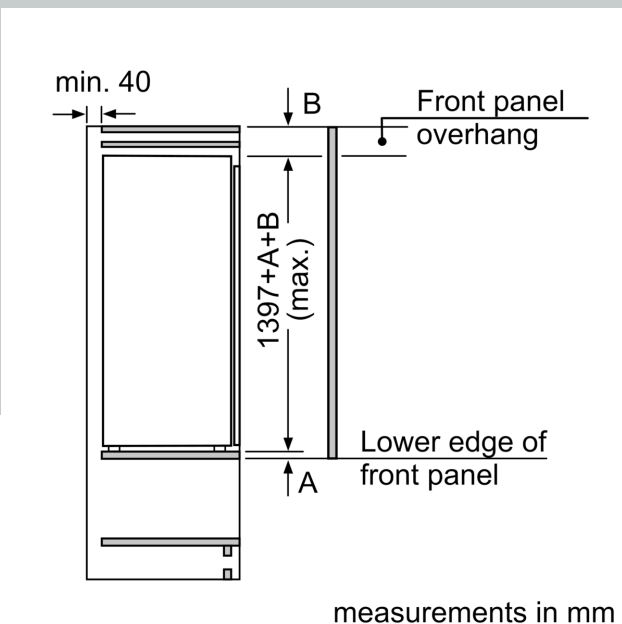
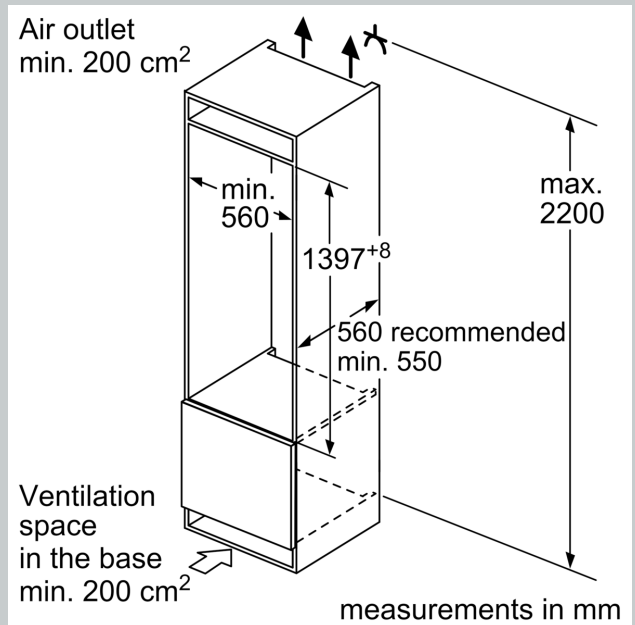
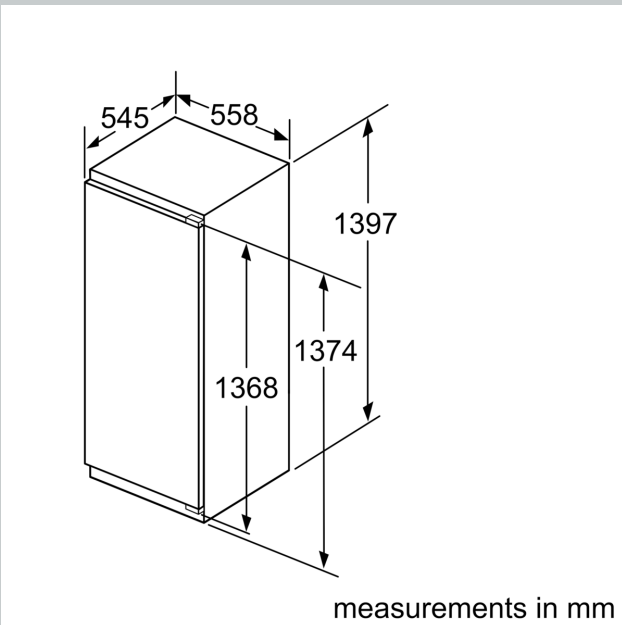

measurements in mm
Recommended gap dimensions for flat hinges

F	R	X
16-19	0-3	2.5
20	0-1	3
	2-3	2.5
21	0-1	3
	2-3	2.5
22	0	4
	1	3.5
	2-3	3

The gap dimensions recommended in the table must be adhered to in order to ensure that appliance doors do not collide with anything when they are opened, and to avoid causing damage to kitchen units.