

N 70, Built-in fridge, 177.5 x 56 cm  
KI1813F30G



COOKING PASSION SINCE 1877



This built-in refrigerator with VarioShelf and many other convenient features keeps food fresh up to twice as long.

- ✓ FreshSafe 2: High humidity and a temperature of +4°C mean that nutrients are retained.
- ✓ FreshSafe: Stores your fruit and vegetables safely
- ✓ EasyAccess Shelf: Provides better organization, with a clearer view and better access to foods.
- ✓ VarioShelf: The glass shelf can be divided and one half pushed beneath the other, for flexible interior configurations.
- ✓ Adjustable Glass Shelves – Height adjustable shelves create the space you need for inspiring dishes in your fridge

#### Features

##### Technical Data

Construction type : Built-in  
 Door panel options : Not possible  
 Height (mm) : 1772  
 Width of the appliance : 558  
 Depth of the product : 545  
 Required niche size for installation (HxWxD) : 1775.0 x 560 x 550  
 Net weight (kg) : 67.184  
 Connection rating (W) : 90  
 Current (A) : 13  
 Door hinge : Right reversible  
 Voltage (V) : 220-240  
 Frequency (Hz) : 50  
 Approval certificates : CE, G-Mark, VDE  
 Length of electrical supply cord (cm) : 230  
 Number of compressors : 1  
 Number of independent cooling systems : 1  
 Interior ventilator : Yes  
 Reversible Door Hinge : Yes  
 Number of Adjustable Shelves in fridge compartment (Stck) : 6  
 Shelves for Bottles : Yes  
 EAN code : 4242004164999  
 Brand : Neff  
 Product name / Commercial code : KI1813F30G  
 Product category : Refrigerator  
 Energy efficiency rating : A++  
 Energy consumption annual (kWh/annum) - NEW (2010/30/EC) : 116.00  
 Refrigerator Net capacity (l) - NEW (2010/30/EC) : 319  
 Freezer Net capacity (l) - NEW (2010/30/EC) : 0  
 Frost free system : No  
 Freezing capacity (kg/24h) - NEW (2010/30/EC) : 0  
 Noise level (dB(A) re 1 pW) : 37  
 Climate class : SN-T  
 Installation type : Full-integrated

#### Optional accessories

Z10020 Bottle Rack



4 242004 164999

## Features

### Performance and Consumption

- Energy consumption: 116 kWh kWh/yr.
- Total net capacity: 319 l litres
- Noise level dB(A) re 1 pW: 37

### Design features

- LED Electronic control
- Right hinged door, reversible

### Food freshness system

- FreshSense - constant temperature by intelligent sensor technology - Constant temperature control by intelligent sensor technology
- Single cooling circuit

### Key features - Fridge section

- 1 FreshSafe 2 drawer on telescopic rails; High humidity retains nutrients up to twice as long.
- 1 FreshSafe drawer on rails - The ideal place to store your fruit and vegetables safely.
- Bottle rack
- Bright interior LED fridge light
- Super Cooling: automatic deactivation
- Acoustic door open warning indicator
- 7 safety glass shelves (6 height adjustable)
- Vario shelf - useful storage when required
- Easy access shelf - easy access and everything in sight
- 6 door trays, including 1x dairy compartment
- 2 x egg tray

### Dimension and installation

- Easy Installation
- Connection value 90 W
- Dimensions: 177.2 cm H x 55.8 cm W x 54.5 cm D
- Niche Dimensions: 177.5 cm H x 56 cm W x 55 cm D
- Climate class SN-T (suitable for ambient temperatures between 10 to 43°C)
- Based on the results of the standard 24-hour test. Actual consumption depends on usage/position of the appliance.

N 70, Built-in fridge, 177.5 x 56 cm  
K1813F30G



COOKING PASSION SINCE 1877

Dimensioned drawings

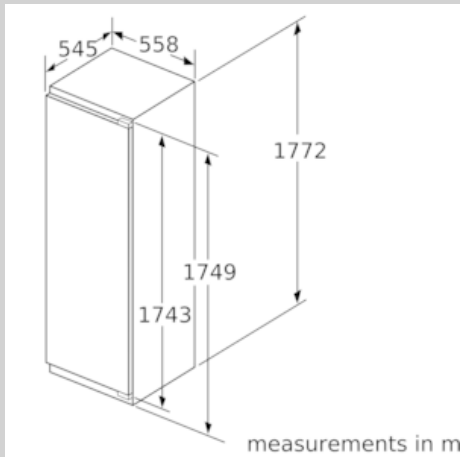

Maximal permissible weight of the unit fronts

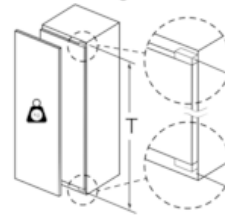

Fitted kitchen unit doors that exceed the permissible weight may cause damage and result in functional impairment of the hinges.

T: Includes height of appliance door Hinges in mm:	undamped hinge, Door in kg:	damped hinge, Door in kg:
1500-1750	22	22

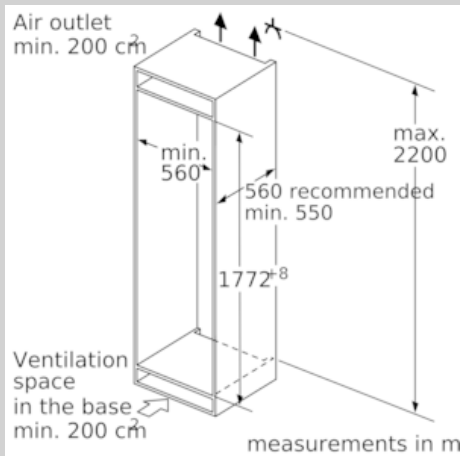

measurements in mm  
Recommended gap dimensions for flat hinges

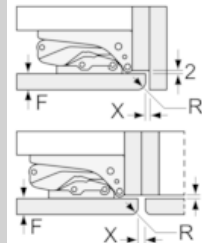

F	R	X
16-19	0-3	2.5
20	0-1	3
	2-3	2.5
21	0-1	3
	2-3	2.5
22	0	4
	1	3.5
	2-3	3

The gap dimensions recommended in the table must be adhered to in order to ensure that appliance doors do not collide with anything when they are opened, and to avoid causing damage to kitchen units.

