

N 70, Built-in vacuum drawer, 14.2 cm  
N17XH10N0B



COOKING PASSION SINCE 1877

NEFF vacuum drawer – the flexible vacuum sealer adds a whole new layer of flavours and opportunities to your kitchen equipment



#### Features

##### Technical Data

Net weight (kg) : 34.655

Gross weight (kg) : 37.2

: MCSA01787170\_G7478\_N17XH10N0\_1218331\_def

EAN code : 4242004218425

Dimensions of the packed product (HxWxD) (mm) : 240 x 660 x 660



4 242004 218425

#### Optional accessories

Z13CX62X0 Vacuum bags 180 x 280 mm, 100 pcs.

Z13CX64X0 Vacuum bags 240 x 350 mm, 100 pcs.

*N 70, Built-in vacuum drawer, 14.2 cm*  
N17XH10NOB

## Features

### Design

- Touch Control illuminated
- Touch key operation
- Automatic connection recognition for vacuuming outside the chamber
- Push-Pull opening mechanism

### Programmes/functions

- 3 vacuuming levels for vacuuming in the chamber, max. 99%
- 3 vacuuming levels for vacuuming outside the chamber, max. 90%
- Drying program for vacuuming pump

### Technical information

- Power cord length 150 cm Cable length
- Cavity Volume: 8 l
- Total connected load electric: 0.32 KW
- Nominal voltage: 220 - 240 V
- Appliance dimension (hxwxd): 140 mm x 595 mm x 542 mm
- Niche dimension (hxwxd): 141 mm x 560 mm - 568 mm x 550 mm
- Please refer to the dimensions provided in the installation manual

N 70, Built-in vacuum drawer, 14.2 cm  
N17XH10N0B

Dimensioned drawings

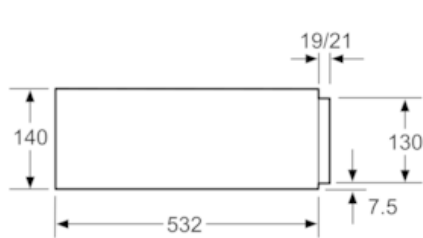

Compact ovens with an appliance height of 455 mm can be installed above a warming drawer. An intermediate floor is not required.

measurements in mm

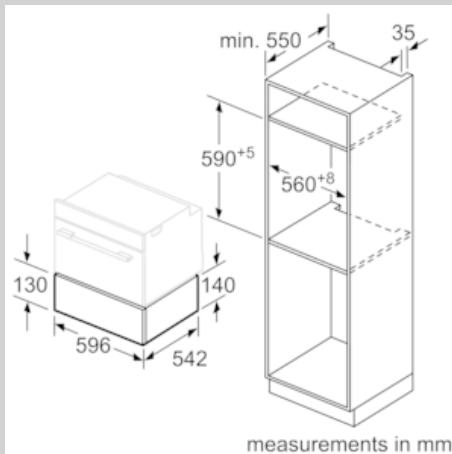

measurements in mm