

N 90, DOMINO GAS HOB, 30 CM, CERAMIC, BLACK  
N23TS19N0



The gas hob with heat-resistant ceramic glass surface and adjustable FlameSelect control.

- ✓ Ceramic Glass Surface - extremely easy-to-clean surface.
- ✓ FlameSelect® – Gain ultimate control of your flame.
- ✓ Pan Supports - continuous cast-iron pan supports for maximum stability and cooking convenience.
- ✓ Biomethane ready – Power your hob with renewable biomethane gas.
- ✓ Sword Knobs - a better feel and easier to operate, the new knob in an attractive design.

#### Features

#### Technical Data

Product name/family: ..... Vario/Domino gas hob w control  
 Product name/family: ..... Vario/Domino gas hob w control  
 Built-in / Free-standing: ..... Built-in  
 Built-in / Free-standing: ..... Built-in  
 Energy input: ..... Gas  
 Energy input: ..... Gas  
 Number of cooking zones: ..... 1  
 Number of cooking zones: ..... 1  
 Min. required niche size for installation (HxWxD): ..... 45 x 270 x 490-500 mm  
 Min. required niche size for installation (HxWxD): ..... 45 x 270 x 490-500 mm  
 Width of the appliance: ..... 306 mm  
 Width of the appliance: ..... 306 mm  
 Dimensions: ..... 59 x 306 x 546 mm  
 Dimensions: ..... 59 x 306 x 546 mm  
 Dimensions of the packed product (HxWxD): . 185 x 397 x 646 mm  
 Dimensions of the packed product (HxWxD): . 185 x 397 x 646 mm  
 Net weight: ..... 7.7 kg  
 Net weight: ..... 7.7 kg  
 Gross weight: ..... 8.8 kg  
 Gross weight: ..... 8.8 kg  
 Residual heat indicator: .....without  
 Residual heat indicator: .....without  
 Location of control panel: ..... Front  
 Location of control panel: ..... Front  
 Basic surface material: ..... Ceramic  
 Basic surface material: ..... Ceramic  
 Color of surface: .....Black, Stainless steel  
 Color of surface: .....Black, Stainless steel  
 Color of frame: .....Black, Stainless steel  
 Color of frame: .....Black, Stainless steel  
 Length electrical supply cord: ..... 100.0 cm  
 Length electrical supply cord: ..... 100.0 cm  
 EAN code: .....4242004268734  
 EAN code: .....4242004268734  
 Gas connection rating: .....6100 W  
 Gas connection rating: .....6100 W  
 Fuse protection: .....3 A  
 Fuse protection: .....3 A  
 Voltage: ..... 220-240 V  
 Voltage: ..... 220-240 V  
 Frequency: ..... 50; 60 Hz  
 Frequency: ..... 50; 60 Hz  
 Included accessories: ..... 1 x WOK attachment ring

#### Included accessories

1 x WOK attachment ring

#### Optional accessories

Z2406X0 Small pot support  
 Z2480X0 Simmer plate  
 Z9914X0 Connecting strip



## N 90, DOMINO GAS HOB, 30 CM, CERAMIC, BLACK N23TS19N0

### Features

#### Design

- ceramic glass surface, black
- Bevelled design, stainless steel
- black cast iron pan supports with protective rubber feet
- Low profile burner: elegant burner design

#### Usage convenience

- FlameSelect with 9 steps: precisely control and adjust the flame in nine defined levels.
- Pan supports dishwasher safe: clean without effort in the dishwasher.
- Design co-ordinated control dials: easily access dials in front with strong grip for effortless turning.
- Ignition via control dials: just push and turn the dials to ignite the flame.

#### Burners and power

- 1 burner hob
- Including 1 wok burner: use an extra wide power range, separately controlling two flame rings.
- Center front: Wok burner up to 6.1 KW (depending on gas type)

#### Safety

- Flame failure safety device: prevents unwanted gas flow when flame goes out.

#### Installation (gas types & measurements)

- Usable for: Nat gas L/LL G25/20mbar(DE)
- NG H/E 20mbar, E+ 20/25mbar Natural gas H 25 mbar (HU) Natural gas L 25 mbar (NL) Liquid gas G30,31 28-30/37mbar Liquid gas G30 37 mbar (PL) Liquid gas 50 mbar
- Factory set for connection to mains gas
- Nozzle set for LPG jets (28-30/37mbar) included. Nozzles for all other gas types can be ordered via the customer service. For nozzle change, please contact the customer service.
- Dimensions of the product (HxWxD mm): 59 x 306 x 546
- Required niche size for installation (HxWxD mm) : 45 x 270 x (490 - 502)
- Min. worktop thickness: 30 mm
- Power cord: 1 m
- Connected load: 6.1 KW

#### Accessories

- 1 x WOK attachment ring included

N 90, DOMINO GAS HOB, 30 CM, CERAMIC, BLACK  
N23TS19N0

Dimensioned drawings

measurements in mm  
Domino combination options with  
corresponding appliance and cut-out dimensions

Width category:  
Appliance width:

	A	B	C	D	L	X		
2x30	306	306	-	-	-	-	612	576
1x30, 1x40	306	396	-	-	-	-	702	666
1x30, 1x60	306	606	-	-	-	-	912	876
1x30, 1x70*	306	708	-	-	-	-	1014	980
1x30, 1x80	306	826	-	-	-	-	1132	1086
1x30, 1x90	306	918	-	-	-	-	1224	1186
2x40	396	396	-	-	-	-	792	756
1x40, 1x60	396	606	-	-	-	-	1002	966
1x40, 1x70*	396	708	-	-	-	-	1104	1070
1x40, 1x80	396	826	-	-	-	-	1222	1176
1x40, 1x90	396	918	-	-	-	-	1314	1276
3x30	306	306	306	-	-	-	918	882
2x30, 1x40	306	306	396	-	-	-	1008	972
2x30, 1x60	306	306	606	-	-	-	1218	1182
2x30, 1x70*	306	306	708	-	-	-	1320	1286
2x30, 1x80	306	306	826	-	-	-	1438	1392
2x30, 1x90	306	306	918	-	-	-	1530	1492
1x30, 2x40	306	396	396	-	-	-	1098	1062
1x30, 1x40, 1x60	306	396	606	-	-	-	1308	1272
1x30, 1x40, 1x70*	306	396	708	-	-	-	1410	1376
1x30, 1x40, 1x80	306	396	826	-	-	-	1528	1482
1x30, 1x40, 1x90	306	396	918	-	-	-	1620	1582
2x40, 1x60	396	396	606	-	-	-	1398	1362
4x30	306	306	306	306	-	-	1224	1188
3x30, 1x40	306	306	306	396	-	-	1314	1278
1x30, 1x75	306	750	-	-	-	-	1056	1020
1x40, 1x75	396	750	-	-	-	-	1146	1110
2x30, 1x75	306	306	750	-	-	-	1362	1326
1x30, 1x40, 1x75	306	396	750	-	-	-	1452	1416

\* Not possible with 70 cm induction hob

Measurements in mm  
Assembly kit (HEZ394301) for Domino

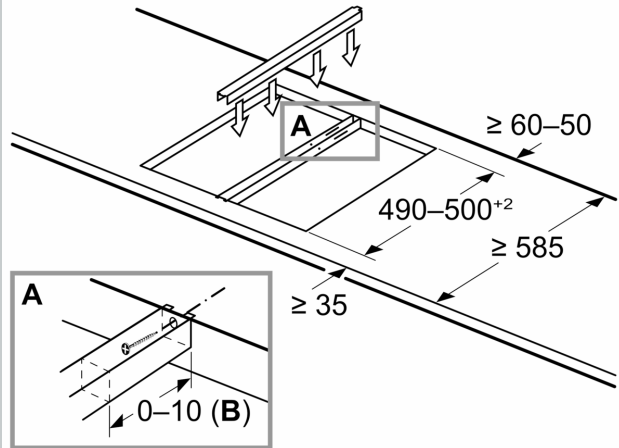

B: Dependent on the cut-out depth

