

CONDENSER TUMBLE DRYER, 9 KG  
R8580X3GB

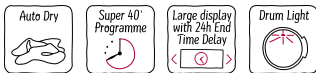

Condenser dryer with large LED display and short drying times.

- ✓ Auto Dry – prevents shrinkage and dries clothes the way you want.
- ✓ Super 40' Programme – dries non-sensitive laundry in just 40 mins
- ✓ Large LED Display – large display for easier navigation and wash programme delay for up to 24 hours
- ✓ Drum illuminates for your convenience.
- ✓ Anti-Vibration Design – Absorbs most vibrations and reduces noise.

Built-in / Free-standing: ..... Free-standing  
 Removable top: ..... No  
 Door hinge: ..... Right  
 Length electrical supply cord: ..... 179.5 cm  
 Dimensions: ..... 842x598x613 mm  
 Net weight: ..... 41.5 kg  
 EAN code: ..... 4242004221463  
 Connection Rating: ..... 2600 W  
 Fuse protection: ..... 13 A  
 Voltage: ..... 220-240 V  
 Frequency: ..... 50 Hz  
 Capacity cotton - NEW (2010/30/EC): ..... 9.0 kg  
 Energy efficiency rating: ..... B  
 Energy consumption electric dryer, full load - NEW (2010/30/EC):  
 5.23 kWh  
 Standard cotton programme time at full load: ..... 150 min  
 Energy consumption electric dryer, partial load - NEW  
 (2010/30/EC): ..... 2.77 kWh  
 Standard cotton programme time at partial load: ..... 80 min  
 Weighted annual energy consumption, electric dryer - NEW  
 (2010/30/EC): ..... 616.0 kWh/a  
 Weighted programme time: ..... 110 min  
 Average condensation efficiency full load (%): ..... 88 %  
 Average condensation efficiency partial load (%): ..... 88 %  
 Weighted condensation efficiency (%): ..... 88 %



WTZ11400 Stacking kit with pull-out shelf  
 WTZ20410 Stacking kit  
 WTZPW20D Platform with pull-out, dryer, cubic

## CONDENSER TUMBLE DRYER, 9 KG R8580X3GB

### Performance

#### Programmes/functions

- Special programmes: Woollens, Mixed Load, Timed programme warm, Timed programme cold, Allergy +, Sportswear, Down wear, Rapid 40, Shirts 15
- Touch control buttons: Low heat, Buzzer, Reduced ironing, Programme length, Start/Pause, fine-tuning for drying level, 24 hours Time Delay, Reduced ironing, fine-tuning for drying level, Low heat, Programme length, ours Time Delay, Buzzer, Start/Pause

#### Key features

- Sensitive drying: large Stainless steel drum and revolution drying system
- AntiVibration design: for greater stability and quietness

#### Additional features

- Large LED display for remaining time and 24 hours time delay, programme progress indication and special functions
- Metal soft dial
- DUO-Tronic drying system
- Anti crease cycle 120 min at the end of the programme
- Drum interior light
- Child safety lock
- Buzzer to indicate the end of cycle
- Door hinge: right-hand
- Container for condensed water

#### Technical Information

- Dimensions (H X W X D): 84.2 x 59.8 x 66.5 cm
- Slide-under
- Glass door,, silver-black grey
- Electronic Humidity Control
- pull-open latch
- Energy Efficiency Class<sup>1</sup>: B
- Energy<sup>2</sup>: 616 kWh
- Capacity: 1 - 9 kg
- Programme time<sup>3</sup>: 150 min
- Noise level: 65 dB (A) re 1 pW
- Condensation efficiency class<sup>4</sup>: B
- Condensation efficiency<sup>5</sup>: 88 %

<sup>1</sup> At a range of energy efficiency classes from A+++ to D

<sup>2</sup> Energy consumption kWh per year, based on 160 drying cycles of the standard cotton programme at full and partial load, and the consumption of the low power modes

<sup>3</sup> Programme time of the standard cotton programme at full load

<sup>4</sup> On a condensation efficiency class scale from A to G

<sup>5</sup> Weighted condensation efficiency for the standard cotton programme at full and partial load

CONDENSER TUMBLE DRYER, 9 KG  
R8580X3GB

Measurements in mm

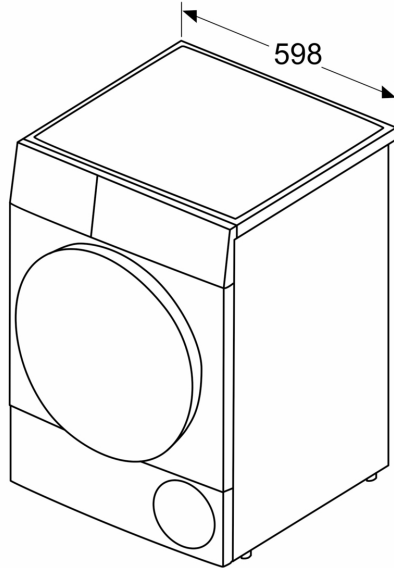

Measurements in mm

