

N 50, INDUCTION HOB WITH INTEGRATED VENTILATION SYSTEM, 80 CM, SURFACE MOUNT WITHOUT FRAME  
T48CB1AX2

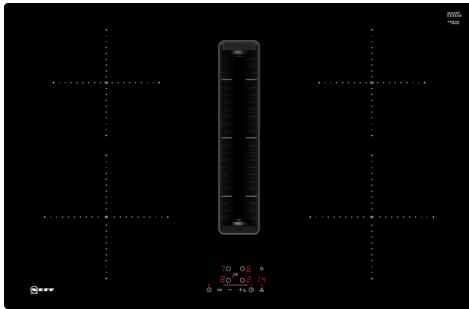

B

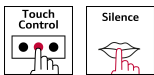

This induction hob with integrated ventilation combines two appliances in one for a clear view while cooking.

- ✓ Touch Control – Control your hob with just one touch and a timer.
- ✓ High Extraction Rate – ensures a clear view while cooking thanks to efficient motor technology.
- ✓ Reduced Noise – our optimized motor guarantees a quiet cooking experience.
- ✓ Easy-clean filters – Easy to remove and dishwasher-safe.
- ✓ Power Boost – An extra surge of heat when you need fast results.

Product name/family: ..... Cooking zone ceramic  
 Built-in / Free-standing: ..... Built-in  
 Energy input: ..... Electric  
 Min. required niche size for installation (HxWxD): 223 x 750-750 x 490-490 mm  
 Width of the appliance: ..... 802 mm  
 Dimensions: ..... 223x802x522 mm  
 Dimensions of the packed product (HxWxD): . 430 x 940 x 670 mm  
 Net weight: ..... 24.2 kg  
 Gross weight: ..... 30.6 kg  
 Residual heat indicator: ..... Separate  
 Location of control panel: ..... Front  
 Basic surface material: ..... Ceramic  
 Color of surface: ..... Black  
 Length electrical supply cord: ..... 110.0 cm  
 Sealed Burners: ..... No  
 heating with booster: ..... All  
 Power of heating element (kW): ..... 2.2 kW  
 Power of 3rd heating element (kW): ..... 1.8 kW  
 Power of 5th heating element (kW): ..... 1.8 kW  
 Power of 3rd heating element (kW in boost): ..... [3.1] kW  
 Number of speed settings: ..... 3-stages + intensive setting  
 Maximum output air extraction: ..... 500 m<sup>3</sup>/h  
 Boost position output recirculating: ..... 595.0 m<sup>3</sup>/h  
 Maximum output recirculating air: ..... 441 m<sup>3</sup>/h  
 Boost position air extraction: ..... 622 m<sup>3</sup>/h  
 Noise level: ..... 69 dB(A) re 1pW  
 Odour filter: ..... No  
 Operating Mode: ..... Convertible  
 Voltage: ..... 220-240/380-415 V  
 Frequency: ..... 50; 60 Hz  
 Included accessories: ..... 1 x Slider for unducted recirculation, 1 x Clean Air Plus odor filter

1 x Slider for unducted recirculation, 1 x Clean Air Plus odor filter

Z811DU0 Acoustics Filter, Z821PD1 Plinth Diffusor, Z821VR0 cleanAir recirculation replenishment fil, Z821VR1 Clean Air Plus odor filter (replacement), Z861KE1 Exhaust kit, Z861KR0 Recirculation kit 2 L-bow (70cm), Z861KR1 Recirculation kit S and L-bow (60cm), Z861KR2 Recirculation kit 1x L-bow, Z861SB1 90° flat duct bend horizontal, Z861SB2 90° flat duct L vertical, Z861SB3 90° flat duct M vertical, Z861SB4 90° flat duct S vertical, Z861SI0 Adapter round-flat, Z861SI1 90° Adapter round-flat, Z861SM1 Straight tube 500mm, Z861SM2 Straight tube 1000mm, Z861SS1 Connector sleeve (female), Z861SS2 Flex sleeve (female), Z9404SE0 4 pieces Set, Z9406SE0 6 pieces Set, Z9428FE0 Iron pan Ø 18 / 28 cm, Z943SE0 Set of 2 pots and 1 pan, Z9453X0 System pan diameter 21cm



N 50, INDUCTION HOB WITH INTEGRATED VENTILATION SYSTEM, 80 CM, SURFACE MOUNT WITHOUT FRAME  
T48CB1AX2

- 80 cm: space for 4 pots or pans.

#### Flexibility of cooking zones

- Cooking zone front left: 210 mm, 2.2 KW (max. power 3.7 KW)
- Cooking zone rear left: 180 mm, 1.8 KW (max. power 3.1 KW)
- Cooking zone rear right: 180 mm, 1.8 KW (max power 3.1 KW)
- Cooking zone front right: 210 mm, 2.2 KW (max. power 3.7 KW)

#### Usage convenience

- Touch control: control the power with imprinted +/- touch buttons.
- Variable 17-stage power settings for each zone: precisely adapt the heat with 17 power levels (9 main levels and 8 intermediate levels).
- Timer with automatic shut off for all zones
- : switches off the cooking zone at the end of the time set (e.g. for boiled eggs).
- LED timer for each zone with switch off function and acoustic signal
- : an alarm sounds at the end of the time set (e.g. for pasta).

#### Time saving & efficiency

- Power Boost function for all zones
- : boil water faster thanks to 50% more energy than at the highest standard level.
- QuickStart function: when switching on, the hob automatically selects the cooking zone with cookware (when placed on a zone whilst the hob is off).
- ReStart function: in case of unintentional switch-off, this feature restores all previous settings by switching on the hob again within 4 seconds.
- Quick-Off: quickly switch off a cooking zone with one longer touch.

#### Design

- Frameless

#### Safety

- 2 stage residual heat indicators: indicates which cooking zones are still hot or warm.
- Control panel lock: prevent unintended activation of the hob.
- Control panel suspension: wipe overboiled liquids without unintentionally changing settings (blocking all touch buttons for 30 seconds).
- Main switch: switch off all cooking zones at the touch of a button.
- Safety cut out facility: for safety reasons, heating stops after a preset time if not used.

#### Installation

- Dimensions of the product (HxWxD mm): 223 x 802 x 522
- Required niche size for installation (HxWxD mm) : 223 x 750 x (490 - 490)
- Min. worktop thickness: 16 mm
- Connected load: 7.4 KW
- 4.6kW power output (20A); current management options for 16A, 13A or 10A connection: limit the maximum power if needed (depends on fuse protection of electric installation).

#### Accessories

- Clean Air Plus odor filter, Slider for unducted recirculation included
- Suitable for installation into a 60 cm base cabinet

#### Integrated ventilation downdraft system

- Induction cooktop with fully integrated high-performance downdraft extractor.
- Suitable for ducted or recirculated extraction configuration (incl. differentiated software modes). Installation accessories for unducted recirculation, among these four cleanAir odor filters and a telescopic slider element, are included in the cooktop. Accessories for other installation options are available, details in the planning notes.
- 
- Aesthetically integrated fully flush air intake design with floating, heat resistant glass ceramics element for free movement and placement of cookware.
- Ventilation system with 3 electronically controlled fan power levels and 1 Boost-/Intensive fan power levels (with automatic revert) via Touch control user interface
- - Automatic switch-on of ventilation system when a cooking zone is used.
- - Automatic delayed shut-off after cooking to erase residual odors after cooking (in specific ultra low-noise fan level, 12min in ducted extraction, 30min in recirculated extraction, can be shut-off manually).
- - Fully manual control possible via Touch control.
- High-performance, low-noise blower with energy-efficient BLDC-technology. High extraction rates at very low noises with pleasant noise frequencies through psycho-acoustically and aerodynamically optimized interior with enclosed, non-visible blower. Highly pressuredrop resistant even with longer and more complex ductings.
- Easy-to-detach and easy-to-clean grease filter and liquid collector unit:
- - Convenient one-hand removal of unit via floating glass ceramics handle.
- - Integrated, large-scale, high performance stainless-steel grease filters with 12 filtration layers and one black top layer for enhanced aesthetical integration. Grease filtration efficiency of 94 %.
- - All parts of the unit are easy-to-clean, fully dishwasher safe and heat resistant.
- - (Upper) Liquid collector unit with 200ml of capacity for standard accidental spillages or cooking condensate.
- - Powerful drainage system for spillages that exceed 200ml of liquids.
- - Liquid safety collector with additional capacity of 700ml for more severe accidental situations. Dishwasher safe. Easily accessible and detachable from below.
- - Overall capturing capacity of 900ml (200ml + 700ml).
- - Watertight blower system.
- Ventilation system performance:
- - Extraction performance in ducted extraction (according to EN

61591): min. normal setting 330 m<sup>3</sup>/h , max. normal setting 500 m<sup>3</sup>/h , max. Boost-/Intensive setting 622 m<sup>3</sup>/h .

- - Extraction performance in recirculated extraction (according to EN 61591): min. normal setting 252 m<sup>3</sup>/h , max. normal setting 441 m<sup>3</sup>/h , max. Boost-/Intensive setting 595 m<sup>3</sup>/h.
- - Noise level in ducted extraction (Sound power level according to EN 60704-3): min. normal setting 61 dB re 1 pW, max. normal setting 69 dB re 1 pW, max. Boost-/Intensive setting 74 dB re 1 pW.
- - Noise level in recirculated extraction (Sound power level according to EN 60704-3. ): min. normal setting 55 dB re 1 pW, max. normal setting 66 dB re 1 pW, max. Boost-/Intensive setting 72 dB re 1 pW.
- - Grease filter efficiency (according to EN 61591) 94 %.
- Consumption data and energy efficiency (according to Regulation (EU) No 65/2014):
- - Energy Efficiency Class: B (at a range of energy efficiency classes from A+++ to D).
- - Fluid Dynamic Efficiency: A .
- - Grease filtration efficiency class: B .
- - Noise min. normal setting & max. normal setting: 61 dB & 69 dB .
- For recirculation configuration: 2 x 2 battery of directly integrated, high-performance cleanAir odor filters.
- - Optimised odour reduction performance for cooking applications with complex odour molecules (e.g. fish).
- - Large scale filter surface with high odour reduction capabilities.
- - Anti-pollen functionality: The filter retains an extremely high amount of airborne pollen and deactivates allergens which are retained by the filter.
- - Lifetime of 360 hours of cooking (non-regenerative).
- - Low-noise filters with optimised psycho-acoustics.
- - Easy-to-access and easy-to-remove from above.
- - Replenishment cleanAir filter set Z821VR0.
- For ducted extraction configuration: 2 x 2 sets of directly integrated, high-performance low-noise acoustic filters for significantly lower noise and improved psycho-acoustics.

#### Planning & installation notes

- Suitable for ducted or recirculated extraction installations in 4 different options (unducted, partly and fully ducted recirculation or ducted extraction). Installation accessories for unducted recirculation, among these four cleanAir odor filters and a telescopic slider element, are included in the cooktop. The included accessories allow easy and quick installations and can be planned in all worktop depths  $\geq 60$ cm. For other types of installation, one of the following accessory kits is recommended:
- Z861KR1 for partly-ducted recirculation in worktops of  $\geq 60$ cm depth with max. worktop height of 960 mm. Z861KR0 for partly-ducted recirculation in worktops of 70cm depth of  $\geq 70$ cm depth with max. worktop height of 960 mm.
- Z861KE1 as starter kit for ducted extraction in worktops of  $\geq 60$ cm depth.
- To complete the fully ducted extraction or to do any other individual recirculation planning different ducting accessories are available.
- Planning suggestions:
- - Installation is possible in island as well as wall oriented configurations.
- The product and its accessories comply with the Needle Flame Test (according to IEC 60695-11-5) and the V2 flammability class (according to UL94).

- - The max. immersion depth is 223 mm below worktop surface.
- - The appliance must be freely accessible from below (i.e. for accessing the lower liquid safety collector).
- - No false floor is necessary below the cooktop with integrated downdraft ventilation system. The drawers and/or shelves in the floor unit must be removable. The backpanel of the floor unit can be kept - only a cut-out for the air outlet is needed (position and size can be taken from the installation instructions).
- An installation with unducted recirculation requires a vertical aperture of min. 25mm behind the backpanel of the furniture. Suggested for ideal performance are 50mm.
- The minimum worktop thickness is 16 mm for top mounted and flush installed appliances with the standard installation system.
- - The overall appliance weight is 26kg - the bearing capacity and stability, in the case of very thin worktops in particular, must be supported using suitable substructures. The overall appliance weight and the worktop manufacturer's structural integrity specifications are to be taken into account.
- - For partly ducted and unducted recirculation extraction installations, a return-flow aperture of  $\geq 400$ cm<sup>2</sup> is to be respected in the plinth area. The aperture can be realized via outlet grids, lamella grids or subtly shortened plinths depending on the assortment of the kitchen furniture manufacturer.
- - The air outlet on the backside of the appliance can directly be accessed with a male flat duct element (DN 150).
- - The pressuredrop resistant blower allows longer and more complex ductings up to 8m with three 90° bows while keeping sufficient performance.
- - When installing a ventilation hood with ducted extraction and a chimney-vented fireplace, the power supply line of the appliance needs a suitable safety switch. This is not required for configurations in recirculated extraction.
- - In ducted extraction configuration a one-way flap (or backflow trap) with a maximum opening pressure of 65Pa should be installed.

N 50, INDUCTION HOB WITH INTEGRATED VENTILATION SYSTEM, 80 CM, SURFACE MOUNT WITHOUT FRAME  
T48CB1AX2

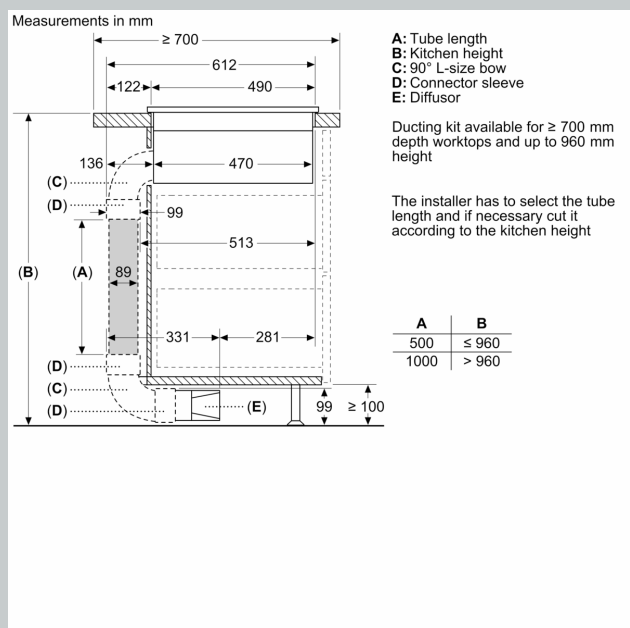
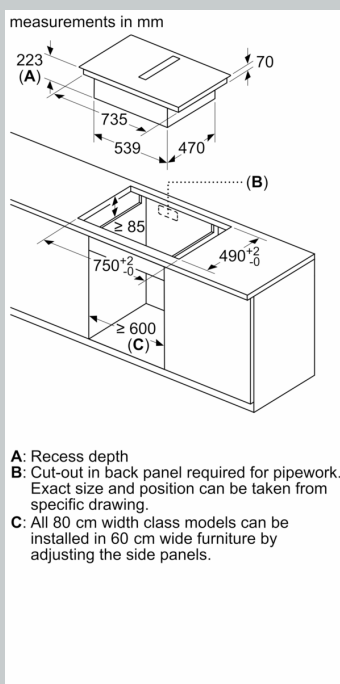
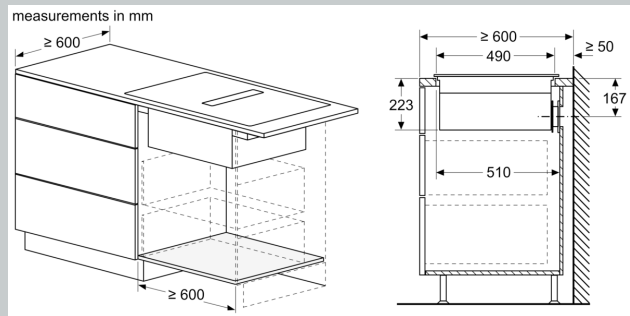
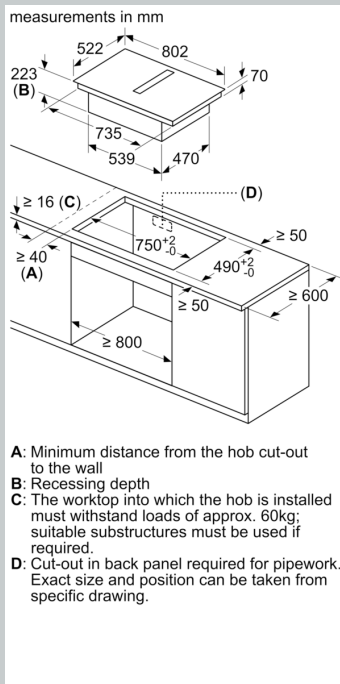

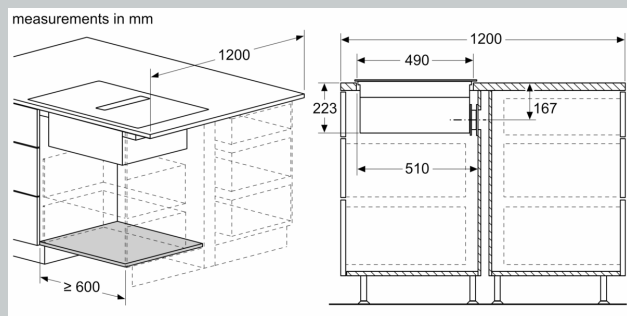
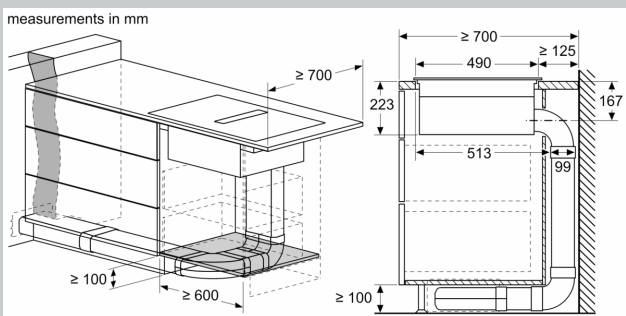
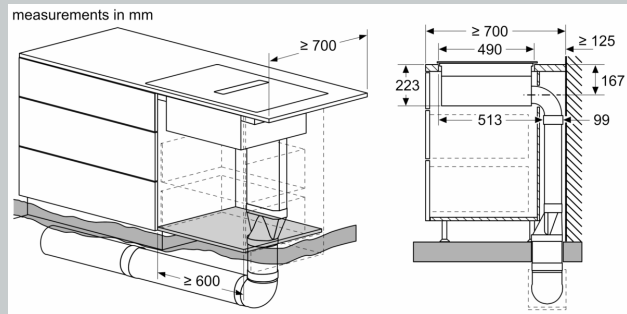
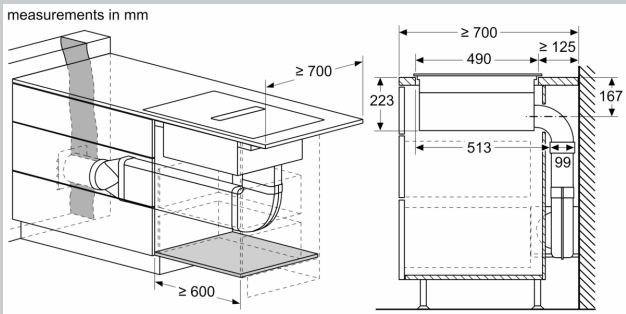
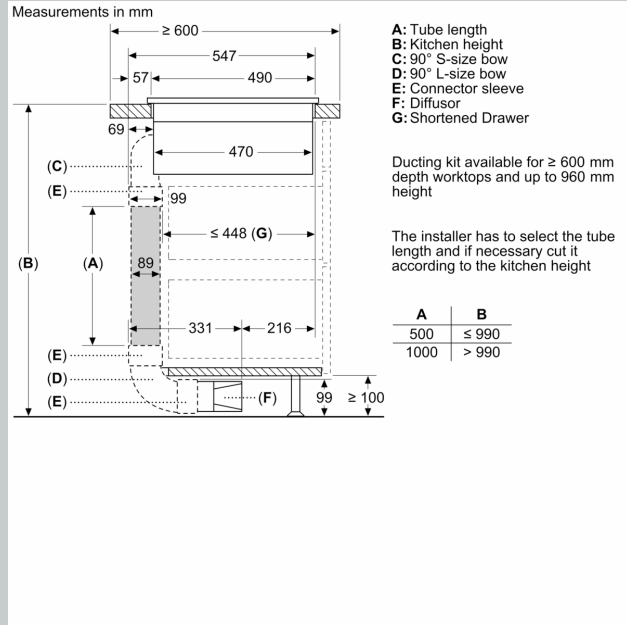
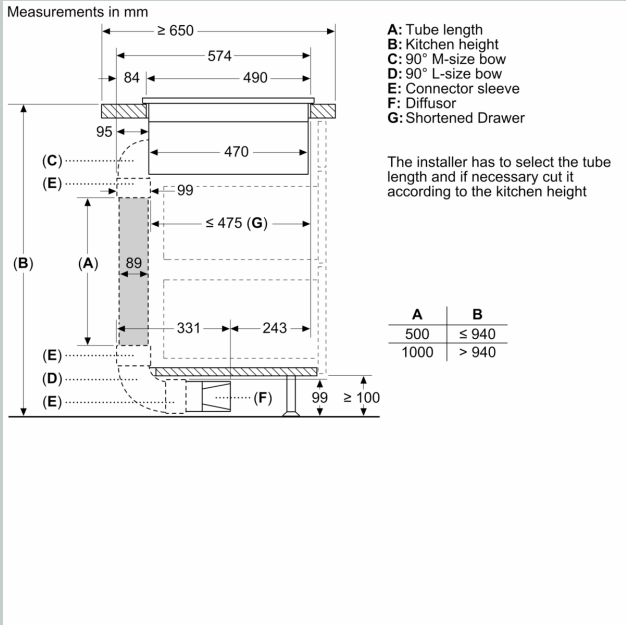

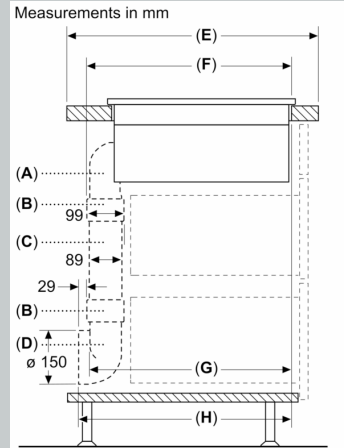
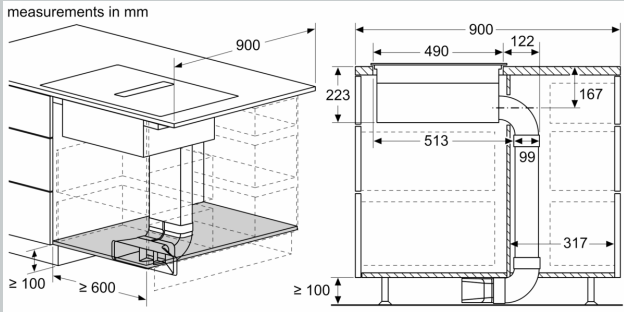

A	E	F	G	H
S-size	≥ 600	547	545	579
M-size	≥ 650	574	569	603
L-size	≥ 700	612	609	643

A: 90° Bow  
 B: Connector sleeve  
 C: Straight tube  
 D: 90° Adapter round-flat

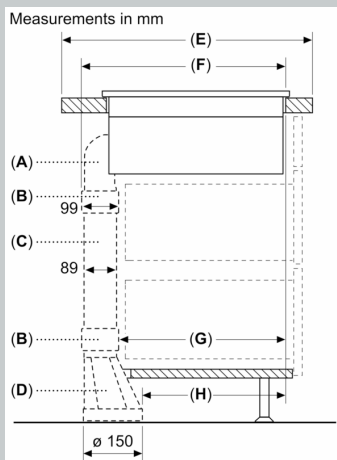

A	E	F	G	H
S-size	≥ 600	547	451	389
M-size	≥ 650	574	475	413
L-size	≥ 700	612	515	453

A: 90° Bow  
 B: Connector sleeve  
 C: Straight tube  
 D: Straight adapter round-flat

measurements in mm  
 Front view

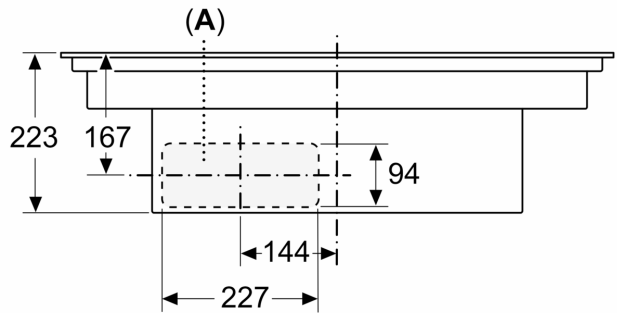

A: Connected directly at the rear

measurements in mm  
Front view - unit cut-out  
for unducted recirculation

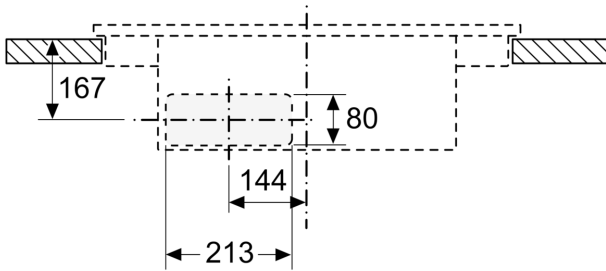

measurements in mm

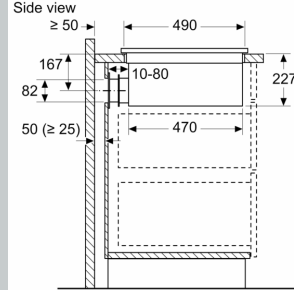

When installing directly against outer walls that are not insulated ( $\mu \geq 0.5 \text{ W/m}^2 \cdot \text{°C}$ ), we recommend using partially or fully ducted recirculation configurations.

measurements in mm  
Front view

