

CLEAN AIR PLUS RECIRCULATION KIT, INITIAL  
EQUIPMENT  
Z51CX1X6

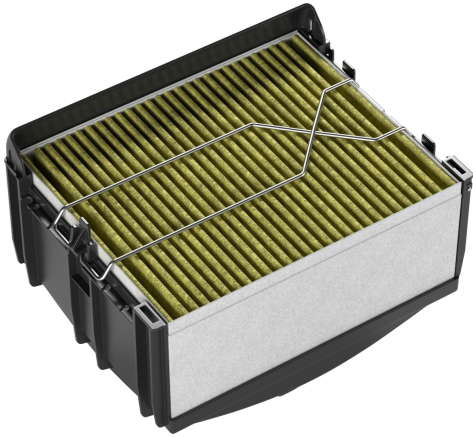

Recirculation kit with CleanAir Plus high performance filters:  
Cleans the air effectively from odours and pollen.

√ Clean Air Plus odour filter – The recirculation filter absorbs a very high amount of kitchen aromas and an extremely high amount of allergy causing pollen.

Features

Technical Data

Dimensions of the packed product (HxWxD): .....300x300x400 mm  
Pallet dimensions: ..... 105.0 x 80.0 x 120.0  
Standard number of units per pallet: ..... 24  
Net weight: ..... 1.7 kg  
Gross weight: ..... 2.9 kg  
EAN code: .....4242004244790



CLEAN AIR PLUS RECIRCULATION KIT, INITIAL  
EQUIPMENT  
Z51CX11X6

Features

**Optional accessories**

- For recirculation operation
- Combined with wall chimney hoods
- Odour reduction > 90%
- Lifetime of CleanAir Plus odour filter 12-18 months
- Anti-fish functionality: Especially treated against fish smell
- Anti-pollen functionality: The filter retains 99% of airborne pollen and deactivates allergens which are retained by the filter.
- Integrated design: Integrated Clean Air Plus recirculation kit is installed not visibly within the chimney. Installation is possible at different heights.
- Consisting of filter holder, Clean Air Plus active carbon filter, flexible hose, 2 hose clamps and mounting material

CLEAN AIR PLUS RECIRCULATION KIT, INITIAL  
EQUIPMENT  
Z51CX11X6

Dimensioned drawings

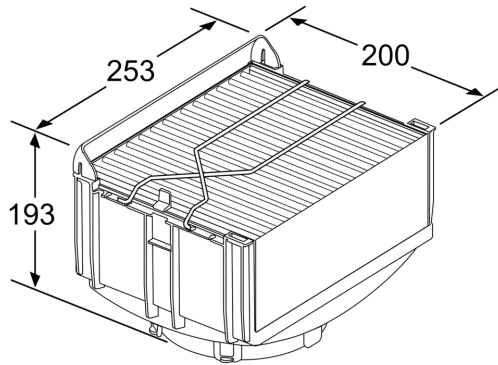

measurements in mm

Measurements in mm

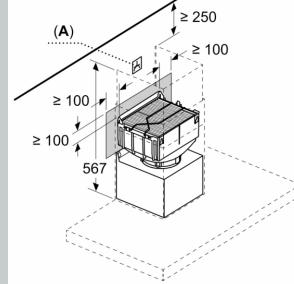

**A:** Socket only outside the marked area

Turn circulated air module 180° when installing on fan box

Socket only outside the marked area

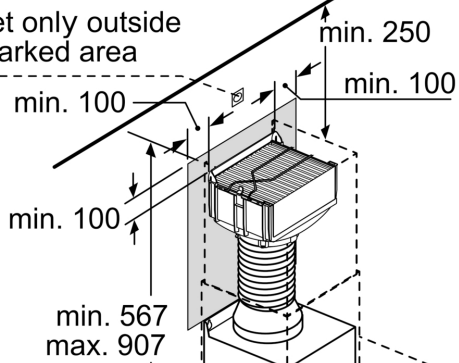

Installation with circulating air slits downwards.

measurements in mm

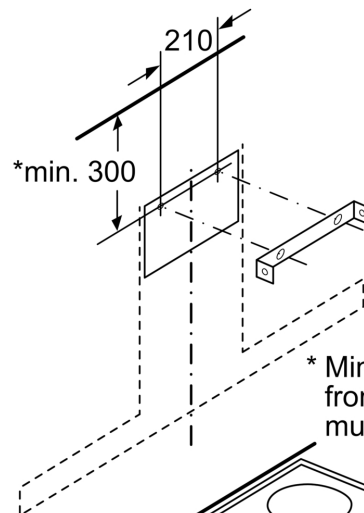

\* Minimum distance from the ceiling must be observed

measurements in mm