

CLEAN AIR PLUS RECIRCULATION KIT, STAINLESS  
STEEL  
Z52JCC1N6

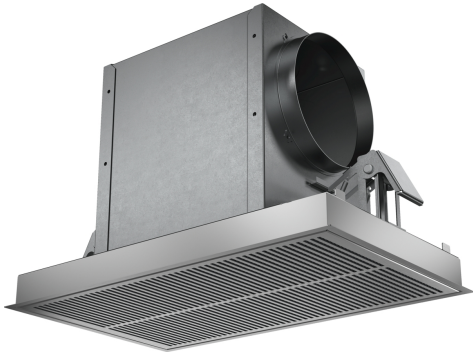

Features

Technical Data

Dimensions of the packed product (HxWxD): .....450x600x400 mm  
Pallet dimensions: ..... 150.0 x 80.0 x 120.0  
Standard number of units per pallet: ..... 16  
Net weight: ..... 4.3 kg  
Gross weight: ..... 6.3 kg  
EAN code: .....4242004244929



CLEAN AIR PLUS RECIRCULATION KIT, STAINLESS  
STEEL  
Z52JCC1N6

Features

**Optional accessories**

- Clean Air Plus recirc. kit external inox
- Colour: stainless steel
- For recirculation operation
- Combined with ceiling hoods
- Odour reduction > 90%
- Lifetime of CleanAir Plus odour filter 12-18 months
- Anti-fish functionality: Especially treated against fish smell
- Anti-pollen functionality: The filter retains 99% of airborne pollen and deactivates allergens which are retained by the filter.
- Connection pipe front, side or top

CLEAN AIR PLUS RECIRCULATION KIT, STAINLESS  
STEEL  
Z52JCC1N6

Dimensioned drawings

measurements in mm  
Air recirculation

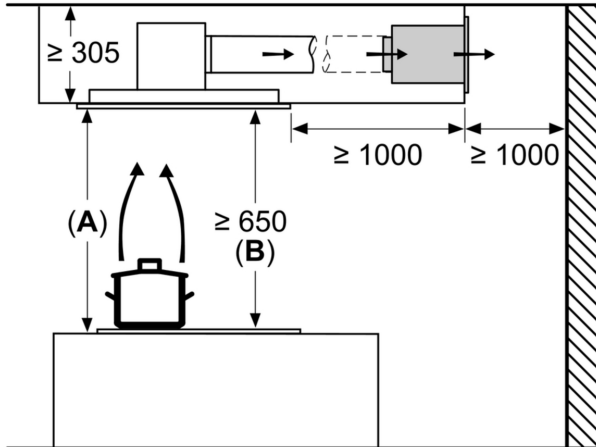

**A:** Optimum performance 700-1500  
**B:** From upper edge of pan support

measurements in mm  
Air recirculation

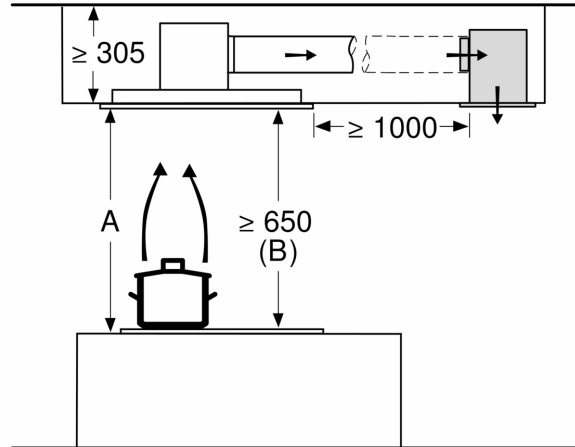

**A:** Optimum performance 700-1500  
**B:** From upper edge of pan support

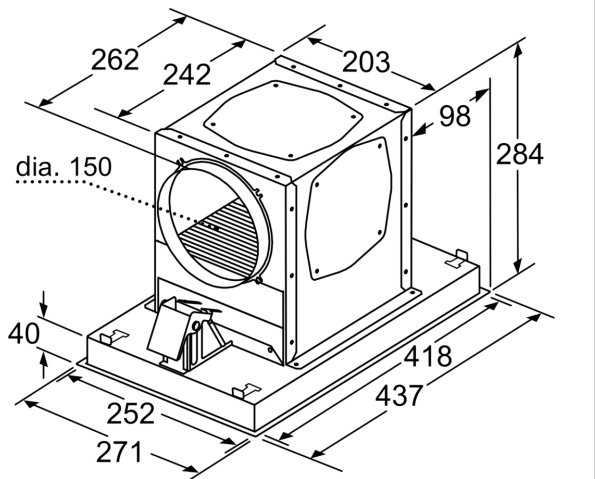

measurements in mm

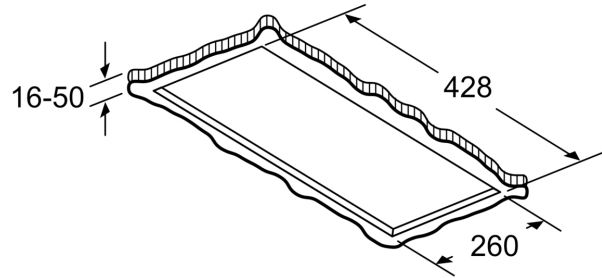

measurements in mm