

CLEAN AIR STANDARD RECIRCULATION KIT  
Z52JXC1W1

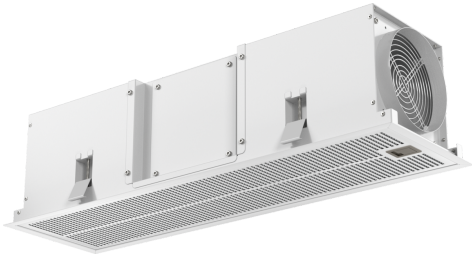

- ✓ Clean Air Stand. recirc. kit ext. white
- ✓ Colour: white
- ✓ For recirculation operation
- ✓ Combined with ceiling hoods
- ✓ Connection pipe front, side or top

Features

Technical Data

Dimensions of the packed product (HxWxD): . 240 x 230 x 770 mm  
 Pallet dimensions: ..... 183.0 x 80.0 x 120.0  
 Standard number of units per pallet: ..... 35  
 Net weight: ..... 5.3 kg  
 Gross weight: ..... 6.7 kg  
 EAN code: .....4242004246961



## CLEAN AIR STANDARD RECIRCULATION KIT Z52JXC1W1

### Features

#### Optional accessories

- Clean Air Stand. recirc. kit ext. white
- Colour: white
- For recirculation operation
- Combined with ceiling hoods
- Connection pipe front, side or top

CLEAN AIR STANDARD RECIRCULATION KIT  
Z52JXC1W1

Dimensioned drawings

measurements in mm

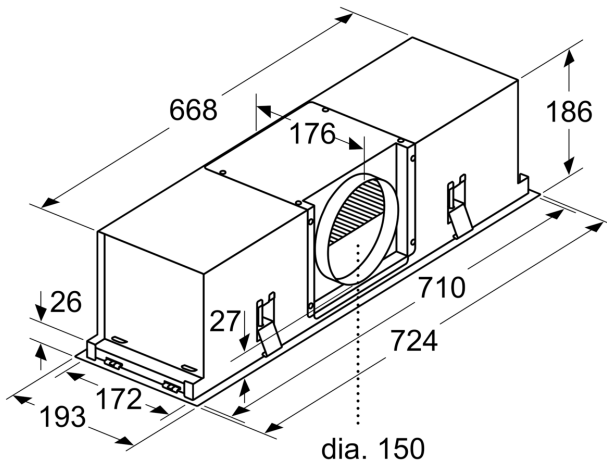

The connecting piece can be offset depending on the installation position.

measurements in mm

