

INSTALLATION ACCESSORY  
Z92WWM11

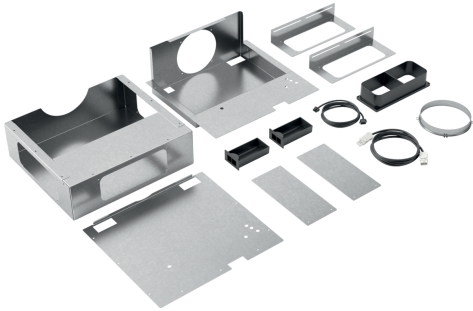

√ Includes necessary installation parts to install the motor up to 3m away from the ventilation unit. Note ducting is required separately.

Features

Technical Data

Dimensions of the packed product (HxWxD): .....455x335x690 mm  
Pallet dimensions: ..... 200.0 x 80.0 x 120.0  
Standard number of units per pallet: ..... 12  
Net weight: ..... 5.8 kg  
Gross weight: ..... 8.8 kg  
EAN code: .....4242004251927



## INSTALLATION ACCESSORY Z92WWM11

### Features

#### Optional accessories

- Includes necessary installation parts to install the motor up to 3m away from the ventilation unit. Note ducting is required separately.

INSTALLATION ACCESSORY  
Z92WWM11

Dimensioned drawings

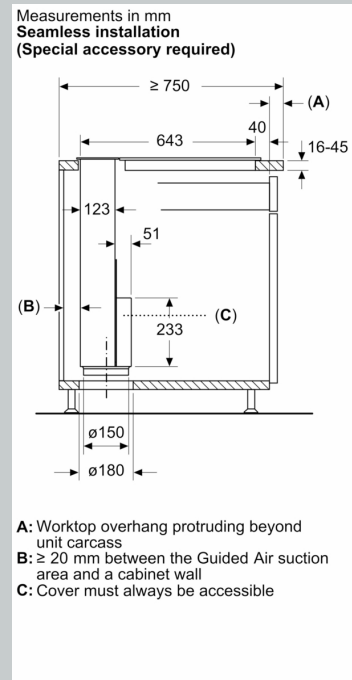
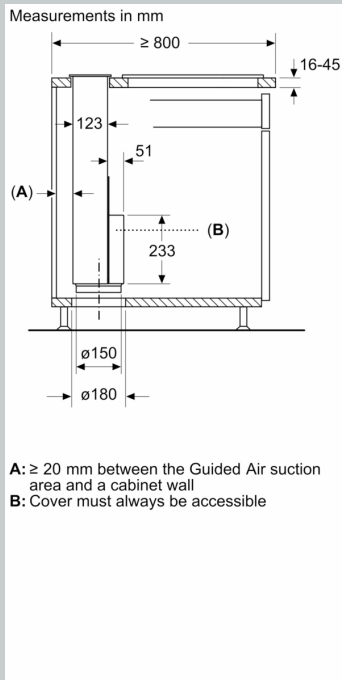

measurements in mm

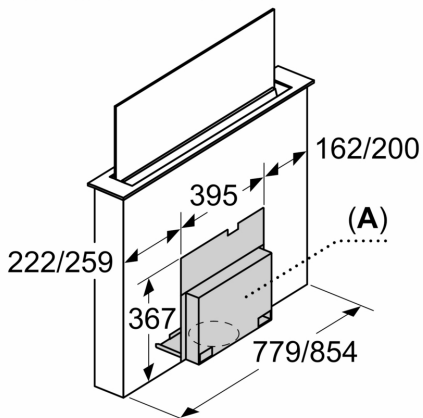

**A:** Access to the entire cover must be ensured even after installation.

The cover can be installed on the front or rear of the appliance.

Example

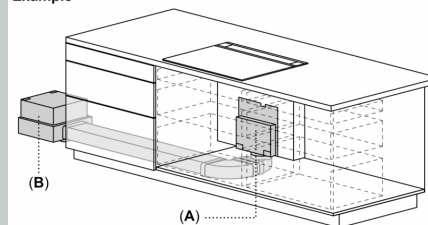

**A:** Cover must always be accessible  
**B:** Clearance between motor unit and appliance max. 3 m  
 Motor unit must always be accessible

Dimensioned drawings

Example

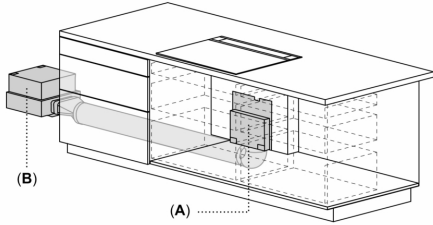

- A: Cover must always be accessible
- B: Clearance between motor unit and appliance max. 3 m  
Motor unit must always be accessible

Example

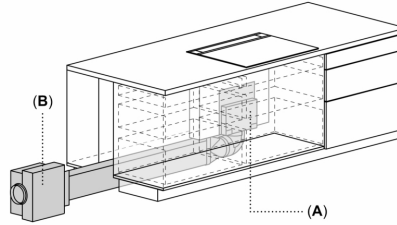

- A: Cover must always be accessible
- B: Clearance between motor unit and appliance max. 3 m  
Motor unit must always be accessible

Measurements in mm

