

N 70, BUILT-IN OVEN, 60 X 60 CM, STAINLESS
STEEL
B17CR32N1B

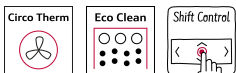

A+



Included accessories

2 x combination grid, 1 x universal pan

Optional accessories

Z12CN10A0 Professional pan, enamelled, Z12CP10A0 Pizza pan, enamelled, Z12CQ10A0 Grill tray, enamelled, Z12CU10A0 Multipurpose pan, enamelled, Z13CR10X0 Baking and roasting grid (steam), Z13CV05S0 Cover Strip, Z1913X0 Baking Stone, Z19DD10X0 Steam set for ovens, Z11AB15A0 Baking tray, non-stick ceramic coated, Z11AU15A0 Universal pan, non-stick ceramic coated, Z11CG10X0 Barbecue-Set, Z11CR10X0 Baking and roasting grid (standard), Z11GT10X3 Glass roasting dish, 5,4l, Z11GU20X0 Glasspan, Z11SZ00X0 SeamlessCombination mounting kit, Z11TC10X0 ComfortFlex Rail (1 level), Z11TC16X0 ComfortFlex Rail (1 level) and racks, Z11TF36X0 3 level telescopic rails, full ext, Z12CB10A0 Baking tray, enamelled, Z12CL10A0 Lid for professional pan, enamelled, Z12CM10A0 Moussaka pan, enamelled

Built-in oven with CircoTherm® - The award-winning hot air system from Neff

- ✓ CircoTherm® – Smart hot-air solution that lets you bake on up to four levels.
- ✓ Eco Clean with Base Clean - the duo that makes oven cleaning easier
- ✓ Shift Control - fast navigation through menus and simple operation with the TFT display.

Features

Technical Data

Built-in / Free-standing: Built-in
 Integrated Cleaning system: EcoClean programme
 Min. required niche size for installation (HxWxD): 585-595 x 560-568 x 550 mm
 Dimensions: 595 x 596 x 548 mm
 Dimensions of the packed product (HxWxD): . 670 x 670 x 680 mm
 Control Panel Material: Glass
 Door Material: Glass
 Net weight: 35.4 kg
 Usable volume (of cavity) - cavity 1: 71 l
 Cooking method: ... CircoTherm®, Bread Baking Setting, Full width grill, Dough proving setting, Hot Air-Eco, Half width grill, Conventional heat, Conventional heat ECO, Pizza setting, low temperature cooking, Bottom heat, Hot air grilling
 Oven control: electronic
 Number of interior lights: 1
 Length electrical supply cord: 120.0 cm
 EAN code: 4242004197263
 Number of cavities (2010/30/EC): 1
 Energy efficiency rating: A+
 Energy consumption per cycle conventional (2010/30/EC): 0.87 kWh/cycle
 Energy consumption per cycle forced air convection (2010/30/EC): 0.69 kWh/cycle
 Energy efficiency index (2010/30/EC): 81.2 %
 Connection Rating: 2990 W
 Fuse protection: 13 A
 Voltage: 220-240 V
 Frequency: 60; 50 Hz
 Plug type: no plug (electrical connection by electrician)
 Included accessories: 2 x combination grid, 1 x universal pan



N 70, BUILT-IN OVEN, 60 X 60 CM, STAINLESS
STEEL
B17CR32N1B

Features

Design

- 2.5" TFT colour display
- Cavity inner surface: enamel anthracite

Features

- Control panel lock
- Automatic safety switch off Residual heat indicator Start button Door contact switch
- Temperature proposal
- Actual temperature display Heating up indicator
- Interior halogen light, On/off button
- Electronic clock timer

Cleaning

- EcoCleanDirect : ceiling, back panel, side liners
- EcoClean programme, Base Clean programme

Programmes/functions

- Rapid heat
- Cooling fan

Accessories

- 2 x combination grid, 1 x universal pan

Performance/technical information

- Energy efficiency rating (acc. EU Nr. 65/2014): A+
- Energy consumption per cycle in conventional mode:0.87 kWh
- Energy consumption per cycle in fan-forced convection mode:0.69 kWh
- Number of cavities: Main cavity Heat source: electrical Cavity volume:71 litre
- Total connected load electric: 2.99 KW
- 120 cm Cable length
- Nominal voltage: 220 - 240 V
- Appliance dimension (hxwxh): 595 mm x 596 mm x 548 mm
- Niche dimension (hxwxh): 585 mm - 595 mm x 560 mm - 568 mm x 550 mm
- Please refer to the dimensions provided in the installation manual

N 70, BUILT-IN OVEN, 60 X 60 CM, STAINLESS
STEEL
B17CR32N1B

Dimensioned drawings

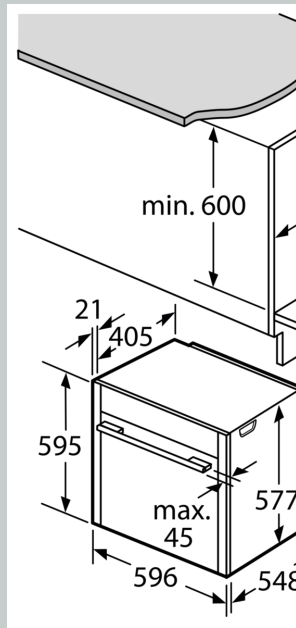
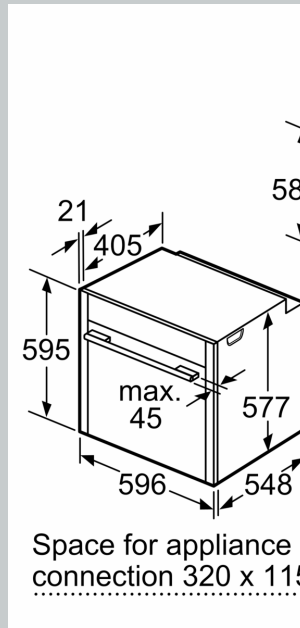
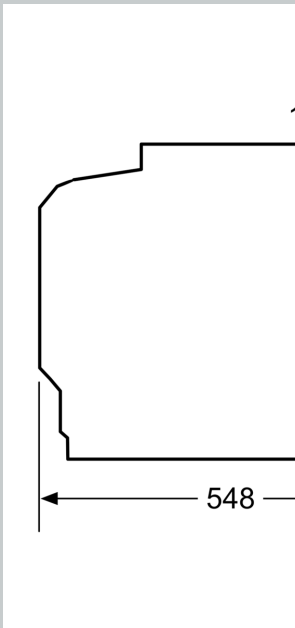

If the appliance will be used as a hob, the following width (including substructure) must be taken into account:

Hob type	min. width
Induction hob	300 mm
Full surface Induction hob	400 mm
Gas hob	300 mm
Electric hob	200 mm