

N 90, Built-in oven with added steam function, Stainless steel
B58VT68NOB

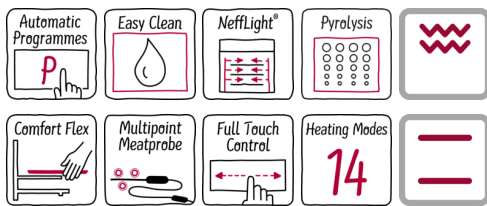

A



Built-in oven with VarioSteam and Slide&Hide® - for enhanced cooking experience with unrestricted access to the oven interior.

- ✓ Slide&Hide® - unrestricted access in the oven interior and easy handling due to rotating handle
- ✓ CircoTherm® - our smart hot-air solution for simultaneous baking and roasting on up to four levels
- ✓ Vario Steam - steam assistance that cooks food moist on the inside and crisp on the outside
- ✓ Dual cleaning options: Pyrolytic cleaning programmes - just let the oven interior clean itself. EasyClean - the quick and easy option for day to day maintenance.
- ✓ FullTouch Control - simple, precise oven control by fingertip touch on the smooth surface of the high resolution TFT colour display.
- ✓ Baking and Roasting Assistant with Automatic Programmes - the duo for optimal baking at your command
- ✓ Multipoint Meatprobe - the thermometer helps the oven regulate the temperature and automatically adjust the cooking time
- ✓ ComfortFlex® - the telescopic rails come out far enough to let you grasp the baking sheet conveniently from the sides.
- ✓ LED lights - Bright illumination exactly where you need it.

Features

Technical Data

Color / Material Front : Stainless steel
 Built-in / Free-standing : Built-in
 Integrated Cleaning system : Hydrolytic, Pyrolytic
 Required niche size for installation (HxWxD) : 585-595 x 560-568 x 550
 Dimensions of the product (mm) : 595 x 596 x 548
 Dimensions of the packed product (HxWxD) (mm) : 675 x 690 x 660
 Control Panel Material : Stainless steel
 Door Material : Glass
 Net weight (kg) : 40.300
 Usable volume (of cavity) - cavity 1 (l) : 71
 Cooking method : Bottom heat, Bread Baking Setting, Conventional heat, Defrost, Full width grill, Half width grill, Hot Air-Eco, Hot air grilling, low temperature cooking, Pizza setting, pre-heating, warming
 Oven control : electronic
 Number of interior lights : 3
 Approval certificates : CE, VDE
 Length electrical supply cord (cm) : 120
 EAN code : 4242004182047
 Number of cavities (2010/30/EC) : 1
 Energy efficiency class (2010/30/EC) : A
 Energy consumption per cycle conventional (2010/30/EC) : 0.90
 Energy consumption per cycle forced air convection (2010/30/EC) : 0.74
 Energy efficiency index (2010/30/EC) : 87.1
 Connection Rating (W) : 3450
 Current (A) : 16
 Voltage (V) : 220-240
 Frequency (Hz) : 60; 50
 Plug type : no plug

Optional accessories

Z11AB15A0 : Baking tray, non-stick ceramic coated ,
 Z11CR10X0 : Baking and roasting grid (standard) ,
 Z11GT10X3 : Glass roasting dish, 5,4l , Z11GU20X0 :
 Glasspan , Z11SZ00X0 : SeamlessCombination mounting kit ,
 Z11SZ80X0 : SeamlessCombination 60 + 29cm , Z11SZ90X0 :
 SeamlessCombination 60 + 45cm , Z11TC10X0 : ComfortFlex
 Rail (1 level) , Z12CB10A0 : Baking tray, anthracite enamelled ,
 Z12CM10A0 : Moussaka pan, anthracite enamelled , Z12CP10A0 :
 Pizza pan, anthracite enamelled , Z12CQ10A0 : Grill tray, anthracite
 enamelled , Z18V60X0 : Cookbook , Z1913X0 : Baking Stone ,
 Z19DD10X0 : Steam set for ovens



4 242004 182047

*N 90, Built-in oven with added steam function,
Stainless steel
B58VT68NOB*

Features

Design

- 5.7" TFT colour and graphics display with FullTouch control
- Cavity inner surface: Enamel anthracite

Features

- Control panel lock Automatic safety switch off Residual heat indicator Start button Door contact switch
- Temperature proposal Actual temperature display Heating up indicator Sabbath setting automatic programmes:
- MultiPoint MeatProbe
- Baking and roasting assistant, Automatic programmes
- NeffLight (2 x 20 Watt halogen lamps), LED light, On/off button
- Water tank empty indicator

Cleaning

- Pyrolytic cleaning
- EasyClean

Programmes/functions

- Oven with 14 heating methods: CircoTherm®, CircoTherm® Gentle, Top/bottom heat, Conventional heat Gentle, Circo-roasting, Full surface grill, Centre surface grill, CircoTherm® intensive, Bread baking, Bottom heat, Low temperature cooking, Defrost, Plate warming setting, Keep warm, Reheat, Dough proving
- Additional heating methods with steam: Reheat, Dough proving
- Additional functions: De-scaling programme Drying function Steam cooking function (Neff system steamer accessory required)
- Number of automatic programmes: 14 PC
- Rapid heat
- Cooling fan

Accessories

- 1-level flexible telescopic rail, full extension, Stop function
- 1 x universal pan, 2 x combination grid

Performance/technical information

- Energy efficiency rating (acc. EU Nr. 65/2014): A Energy consumption per cycle in conventional mode: 0.9 kWh Energy consumption per cycle in fan-forced convection mode: 0.74 kWh Number of cavities: Main cavity Heat source: electrical Cavity volume: 71 litre
- 1 l Water tank capacity
- Location of water tank: Outside cavity
- Total connected load electric: 3.45 KW
- 120 cm Cable length
- Nominal voltage: 220 - 240 V
- Appliance dimension (hxwxd): 595 mm x 596 mm x 548 mm
- Niche dimension (hxwxd): 585 mm - 595 mm x 560 mm - 568 mm x 550 mm
- Please refer to the dimensions provided in the installation manual

N 90, Built-in oven with added steam function,
Stainless steel
B58VT68NOB

Dimensioned drawings

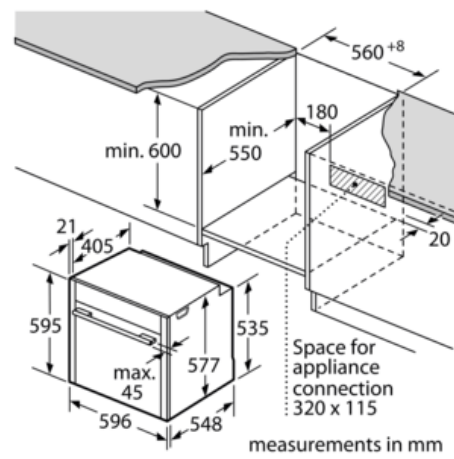
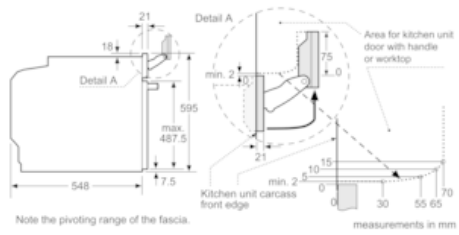

If the appliance will be installed underneath a hob, the following worktop thicknesses (including substructure if necessary) must be taken into account.

Hob type	min. worktop thickness	
	fitted	flush
Induction hob	37 mm	38 mm
Full surface Induction hob	47 mm	48 mm
Gas hob	30 mm	38 mm
Electric hob	27 mm	30 mm

