

N 90, downdraft hood, 90 cm, clear glass black printed
D95DAP8NOB



COOKING PASSION SINCE 1877



The quiet Downdraft hood with a high extraction rate can be extended from the worktop whenever steam and culinary odours arise.

- ✓ Extendable – Emerges only when needed and sits neatly behind the hob for a clear view in the kitchen
- ✓ Space-saving miracle – Fits neatly behind the hob for more use of the cabinet space underneath
- ✓ Flexible installation – A range of installation options make the most of your cabinet space
- ✓ Quiet operation – Particularly quiet due to its noise-optimised design
- ✓ Integrated lighting – Our downdraft hood with integrated LED lights for clear lighting over your hob

A

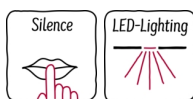

Features

Technical Data

Typology : Downdraft
Length electrical supply cord : 150 cm
Min. required niche size for installation (HxWxD) : 735mm x 844.0mm x 104mm mm
Height of the appliance : 735-1035/735-1035 mm
Net weight : 35.9 kg
Type of control : Electronic
Number of speed settings : 3-stage + 2 intensive
Maximum output air extraction : 530 m³/h
Boost position output recirculating : 500.0 m³/h
Maximum output recirculating air : 452 m³/h
Boost position air extraction : 750 m³/h
Number of lights : 1
Noise level : 62 dB(A) re 1 pW
Diameter of air outlet : 150 mm
Grease filter material : Washable aluminium
EAN code : 4242004230731
Connection Rating : 317 W
Fuse protection : 10 A
Voltage : 220-240 V
Frequency : 50 Hz
Plug type : GB plug
Installation typology : Built-in

Optional accessories

Z92IDM9X0 Mounting kit remote motor
Z92IDP9X0 Long Life recirculation kit
Z92IDQ9X0 Long Life odor filter (replacement)



4 242004 230731

N 90, downdraft hood, 90 cm, clear glass black
printed
D95DAP8NOB



COOKING PASSION SINCE 1877

Features

Key performance features:

- Energy Efficiency Class: A (at a range of energy efficiency classes from A+++ to D)
- Extraction rate according to EN 61591 \varnothing 15 cm:
max. Normal use 530m³/h
Intensive 750 m³/h
- Noise max. Normal Level: 62 dB*

Features

- Touch control for extractor speeds and light
- 3 power levels and 2 intensive settings
- 1 x 7W LED-module
- Automatic after running (10 minutes)
- 2 metal grease filter cassettes
- Saturation indicator for metal and charcoal filter

Design

- Worktop ventilation
- Downdraft for installation in worktops
- Extension height 300 mm
- Rim ventilation
- Electronic controls

Performance/technical information

- Suitable for ducted extraction and recirculation
- For recirculated extraction recirculating kit (accessory) needed
- In recirculation mode no combination with gas hobs allowed.
- Noise level according to EN 60704-3 and EN 60704-2-13 exhaust air:
Max. normal use: 62dB(A) re 1 pW
Intensive: 67 dB(A) re 1 pW
- Extraction rate in recirculation mode:
Max. normal use: 452m³/h
Intensive: 500 m³/h
- Noise levels in recirculation mode:
Max. normal use: 72dB(A) re 1 pW
Intensive: 75 dB(A) re 1 pW
- Power rating: 317 W
- Light Intensity: 203 lux
- Colour Temperature: 3500 K
- Electrical cable length 1.5 m
- Blower Efficiency Class: A*
- Lighting Efficiency Class: A*
- Grease Filtering Efficiency Class: D*
- Average Energy Consumption: 54.2 kWh/year*
- Diameter pipe \varnothing 150 mm (\varnothing 150 mm enclosed)
- Dimensions exhaust air (HxWxD): 735-1035 x 918 x 268 mm
- Dimensions recirculating (HxWxD): 735-1035 x 918 x 268 mm

Optional accessories

- Recirculating kit Z92IDM9X0
- * In accordance with the EU-Regulation No 65/2014

N 90, downdraft hood, 90 cm, clear glass black printed
 D95DAP8NOB

Dimensioned drawings

Combination with electric hob

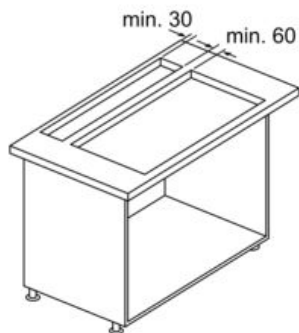

For use with gas hob see drawing
 "Combination with gas hob".

measurements in mm

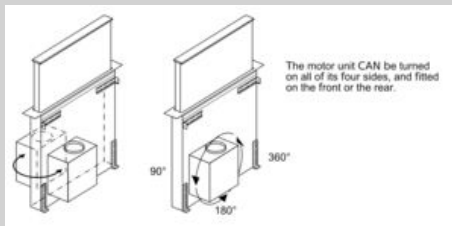
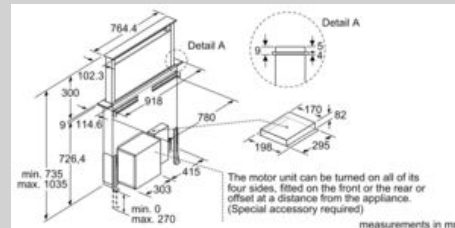

measurements in mm

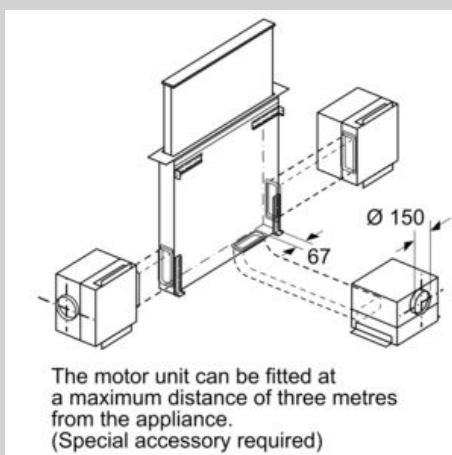
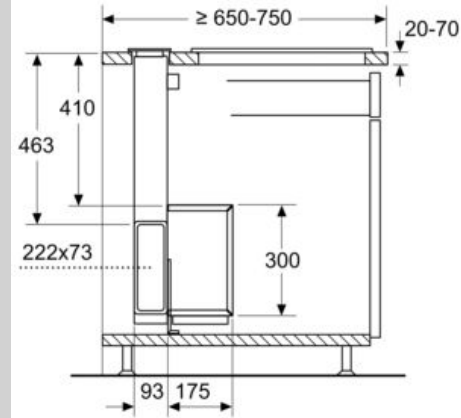

Combination with gas hob 75 cm

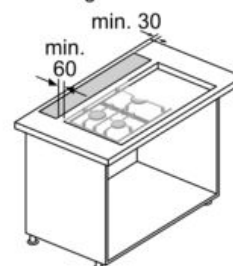

Use with gas hob only possible
 in air extraction mode.
 Total maximum output: 11.9 kW
 Maximum output of wok 4.2 kW.
 Total maximum output of rear hobs: 4.7 kW

measurements in mm

N 90, downdraft hood, 90 cm, clear glass black
 printed
 D95DAP8NOB

Dimensioned drawings

Combination with gas hob 90 cm



Use with gas hob only possible
 in air extraction mode.
 Total maximum output: 13.7 kW
 Maximum output of wok 6 kW.
 Total maximum output of rear hobs: 4.7 kW

measurements in mm

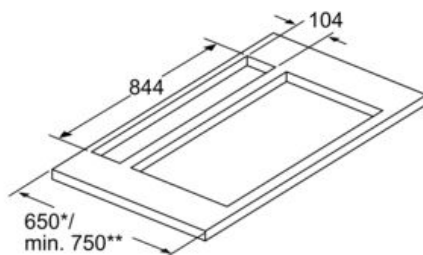

Only install one side of the appliance at
 least 50 mm from a high-sided unit or a wall.

* 650 mm depth only in combination with
 slim hobs.

** min. 750 mm for hobs with 500 mm
 cut-out depth.

measurements in mm