

N 70, built-in freezer, 177.2 x 55.8 cm
G17813E30G



COOKING PASSION SINCE 1877



This NoFrost built-in freezer needs no defrosting and features a malfunction warning signal in case of increasing temperature.

- ✓ NoFrost: No more manual thawing. The air circulates to stay dry so there's no ice buildup.
- ✓ Vario Zone – Individualize your drawers with various loading options to create the optimal fit for frozen goodies
- ✓ Super Freeze – Lowers the temperature temporarily to prevent frozen goods from warming up as new items are added.

Features

Technical Data

Thermometer freeze section : Digital
Light : No
Product category : Upright freezer
Built-in / Free-standing : Built-in
Door panel options : Not possible
Frost free system : Fridge and freezer
Height without worktop / build under (mm) : 1772
Width of the appliance : 558
Depth (mm) : 545
Dimensions of the packed product (HxWxD) (mm) : 1840 x 640 x 620
Net weight (kg) : 68.006
Gross weight (kg) : 73.2
Connection Rating (W) : 120
Current (A) : 13
Frequency (Hz) : 50
Approval certificates : CE, VDE
Length electrical supply cord (cm) : 230
Door hinge : Left reversible
Storage Period in Event of Power Failure (h) : 22
Warning signal / malfunction : visual and audible
Lockable door : No
Number of drawers/baskets (Stck) : 5
Number of freezing flaps (Stck) : 2
EAN code : 4242004199564
Brand : Neff
Product name / Commercial code : G17813E30G
Product category : Upright freezer
Energy efficiency rating : A++
Energy consumption annual (kWh/annum) - NEW (2010/30/EC) : 243.00
Freezer Net capacity (l) - NEW (2010/30/EC) : 211
Freezing capacity (kg/24h) - NEW (2010/30/EC) : 20
Climate class : SN-T
Noise level (dB(A) re 1 pW) : 36
Installation typology : Full-integrated



4 242004 199564

N 70, built-in freezer, 177.2 x 55.8 cm
G17813E30G

Features

Performance and Consumption

- Energy consumption: 243 kWh kWh/yr.
- Energy consumption: 1 kWh/24 hours
- Total net capacity: 211 litres
- Noise level dB(A) re 1 pW: 36

Design features

- Full frost free, never have to defrost ever again
- Left hinged door, reversible
- Fixed hinge
- Electronic control (7 segment display)

Food freshness system

- vitaControl - constant temperature by intelligent sensor technology - Constant temperature control by intelligent sensor technology

Key features - Freezer section

- Full frost free
- 4 star freezer rating
- Removeable safety glass shelves in freezer
- 5 freezer drawers
- 1 compressor/1 cooling circuit
- SuperFreeze function with automatic deactivation
- Freezing capacity in 24 hours: 20 kg
- Maximum freezer storage time in power failure: 22 hours

Functions

- Acoustic warning system
- Freezer malfunction warning signal: optical, acoustical

Accessories

- cold accumulator, ice cube tray

Dimension and installation

- Climate class SN-T (suitable for ambient temperatures between 10 to 43°C)
- Connection value 120 W
- Dimensions: 177.2 cm H x 55.8 cm W x 54.5 cm D
- Niche Dimensions: 177.5 cm H x 56 cm W x 55 cm D
- 2 hinged freezer compartment

N 70, built-in freezer, 177.2 x 55.8 cm
G17813E30G

Dimensioned drawings

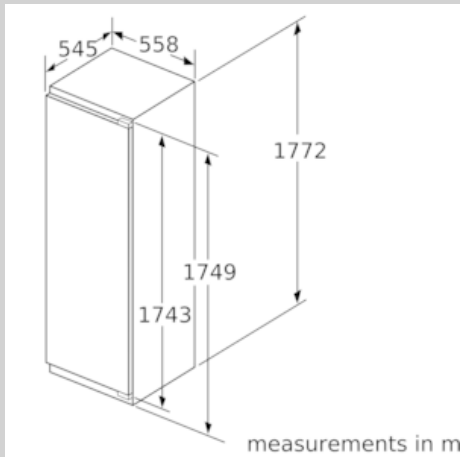

Maximal permissible weight of the unit fronts

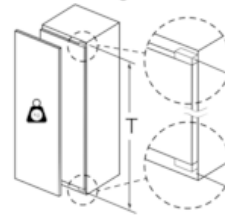

Fitted kitchen unit doors that exceed the permissible weight may cause damage and result in functional impairment of the hinges.

T: Includes height of appliance door	undamped hinge,	damped hinge,
Hinges in mm:	Door in kg:	Door in kg:
1500-1750	22	22

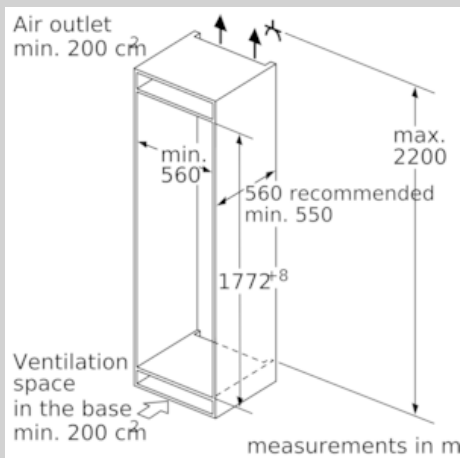

measurements in mm
Recommended gap dimensions for flat hinges

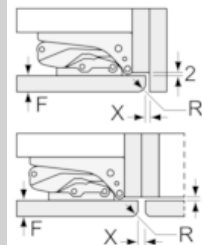

F	R	X
16-19	0-3	2.5
20	0-1	3
	2-3	2.5
21	0-1	3
	2-3	2.5
22	0	4
	1	3.5
	2-3	3

The gap dimensions recommended in the table must be adhered to in order to ensure that appliance doors do not collide with anything when they are opened, and to avoid causing damage to kitchen units.

