

N 30, built-in microwave
H53W50N3GB



COOKING PASSION SINCE 1877



- ✓ Side-opening hinged door - A smart twist for the elevated installation.
- ✓ LED-Display - simple, straightforward for clear reading

Features

Technical Data

Type of micro-wave oven : MW only
Type of control : Electronic
Color / Material Front : Stainless steel
Dimensions : 364 x 453 x 320 mm
Cavity dimensions : 194.0 x 290 x 285.0 mm
Length electrical supply cord : 130 cm
Net weight : 15.2 kg
Gross weight : 17.2 kg
EAN code : 4242004159377
Maximum micro-wave power : 800 W
Connection Rating : 1270 W
Fuse protection : 10 A
Voltage : 230 V
Frequency : 50 Hz
Plug type : GB plug
Cavity dimensions : 194.0 x 290 x 285.0 mm
Included accessories : 1 x mounting frame



N 30, built-in microwave
H53W50N3GB



COOKING PASSION SINCE 1877

Features

Design

- LED display, white
- Left hinged door
- 24.5 cm Glass turntable
- Interior light

Programmes/functions

Accessories

- 1 x mounting frame

Performance/technical information

- Cavity volume: 17 l
- 130 cm Cable length
- Total connected load electric: 1.27 KW
- Nominal voltage: 230 V
- Appliance dimension (hxwxh): 364 mm x 453 mm x 320 mm
- Niche dimension (hxwxh): 362 mm - 362 mm x 462 mm - 468 mm x 320 mm
- Please refer to the dimensions provided in the installation manual

Dimensioned drawings

measurements in mm
installation in a wall-hanging cupboard
Microwave ovens
Built-in frame
Overhang

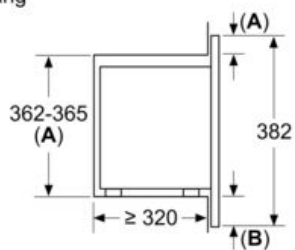

A: Overhang at top:
Recess 362: 6 mm
Recess 365: 3 mm
B: Overhang at bottom: 14 mm

measurements in mm

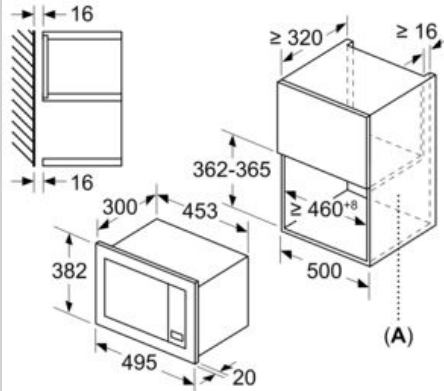

A: Back panel open