

N 50, BUILT-IN MICROWAVE, BLACK  
HLAWD23NOB



A must for any household - a built-in microwave designed to coordinate with N50 ovens

- ✓ Side-opening hinged door - A smart twist for the elevated installation.
- ✓ Control Dials & One-Touch Buttons - select the right programme using your intuition
- ✓ LED-Display - simple, straightforward for clear reading
- ✓ Automatic programmes - Your kitchen helper with just the right default settings.
- ✓ LED lights - Bright illumination exactly where you need it.

#### Features

##### Technical Data

Type of micro-wave oven: .....	MW only
Type of control: .....	Electronic
Dimensions: .....	382 x 594 x 317 mm
Cavity dimensions: .....	201.0 x 308.0 x 282.0 mm
Length electrical supply cord: .....	130.0 cm
Net weight: .....	15.9 kg
Gross weight: .....	18.2 kg
EAN code: .....	4242004222774
Maximum micro-wave power: .....	800 W
Connection Rating: .....	1270 W
Fuse protection: .....	10 A
Voltage: .....	230-240 V
Frequency: .....	50 Hz
Plug type: .....	GB plug



## N 50, BUILT-IN MICROWAVE, BLACK HLAWD23NOB

### Features

#### Design

- LED display, white
- Electronic clock timer
- Left hinged door
- 25.5 cm Glass turntable
- Cavity inner surface: stainless steel
- Bevelled oval controls, Retractable controls dials, Touch control, round, Start button

#### Features

- Automatic safety switch off
- Door contact switch
- Cooling fan
- Memory function
- LED light
- Open Button, electronic

#### Programmes/functions

- 90-180-360-600-800 Watts and the following options: 180 W, 360 W, 600 W, 800 W, 90 W
- Number of automatic programmes: 7 PC
- 4 defrost and 3 cooking programmes in microwave function

#### Performance/technical information

- Cavity volume: 20 l
- 130 cm Cable length
- Total connected load electric: 1.27 KW
- Nominal voltage: 230 - 240 V
- Appliance dimension (hxwxh): 382 mm x 594 mm x 317 mm
- Niche dimension (hxwxh): 362 mm - 365 mm x 560 mm - 568 mm x 300 mm
- Please refer to the dimensions provided in the installation manual

N 50, BUILT-IN MICROWAVE, BLACK  
HLAWD23NOB

Dimensioned drawings

Microwave,  
corner installation

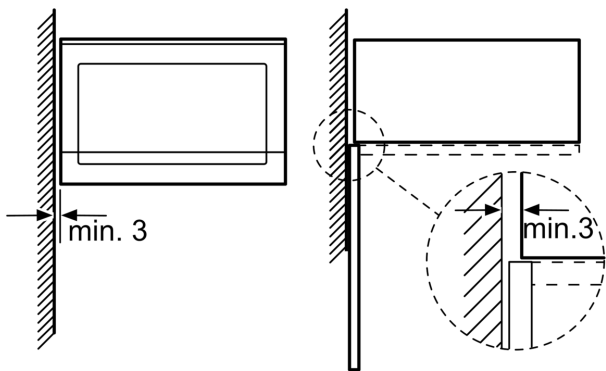

Measurements in mm

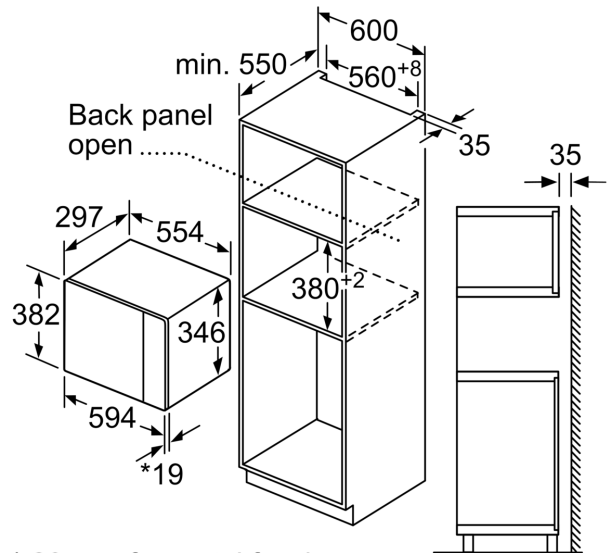

\* 20 mm for metal fascia

measurements in mm

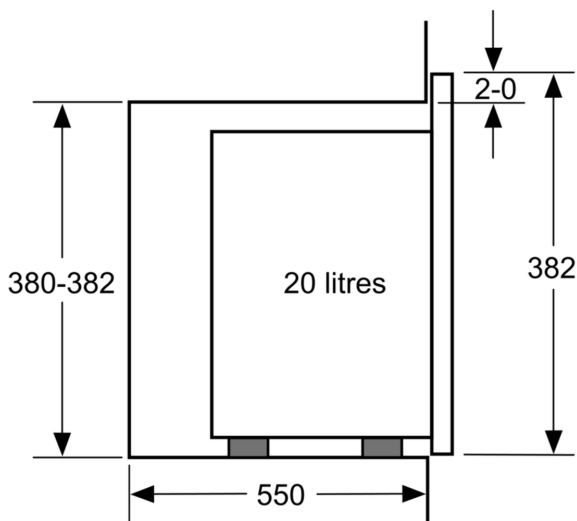

measurements in mm

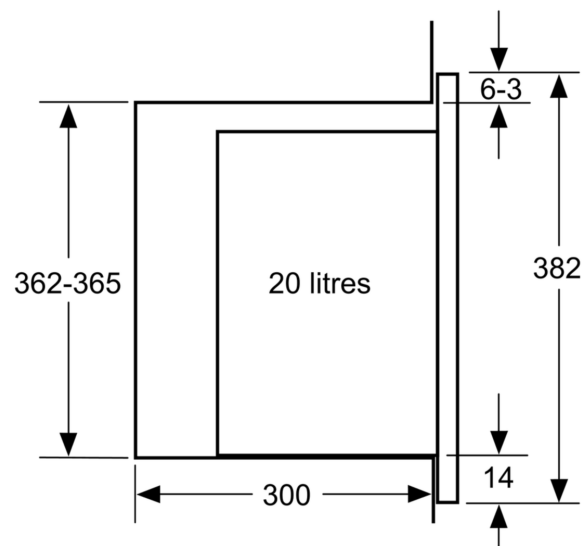

measurements in mm