

N 50, BUILT-UNDER DOUBLE OVEN
J1ACE4HN0B



A



Built under double oven - twice as flexible, twice as fast - bake or roast multiple dishes at the same time.

- ✓ Eco Clean with Easy Clean - the duo that makes oven cleaning easier
- ✓ LCD-Display - simple, straightforward with large characters for clear reading
- ✓ Cliprails - Place dishes exactly where you want them in your oven.

Features

Technical Data

Built-in / Free-standing: Built-in
 Integrated Cleaning system: No
 Dimensions: 717 x 594 x 550 mm
 Dimensions of the packed product (HxWxD): . 790 x 660 x 690 mm
 Control Panel Material: Glass
 Door Material: Glass
 Net weight: 47.4 kg
 Usable volume (of cavity) - cavity 1: 47 l
 Cooking method: Full width grill, Hotair gentle, Hot Air, Conventional heat, Pizza setting, Bottom heat, Hot air grilling
 Oven control: mechanical
 Number of interior lights: 1
 EAN code: 4242004222002
 Energy efficiency rating: A
 Energy consumption per cycle conventional (2010/30/EC): 0.84 kWh/cycle
 Energy consumption per cycle forced air convection (2010/30/EC): 0.71 kWh/cycle
 Energy efficiency class (2010/30/EC) - cavity 2: B
 Energy consumption per cycle conventional - cavity 2 (2010/30/EC): 0.83 kWh/cycle
 Energy efficiency index (2010/30/EC): 94.7 %
 Energy efficiency index cavity 2 (2010/30/EC): 120.3 %
 Connection Rating: 5300 W
 Fuse protection: 25 A
 Voltage: 220-240 V
 Frequency: 50 Hz
 Plug type: no plug (electrical connection by electrician), fixed connection (electrical connection by electrician)
 Included accessories cavity 1: ... 2 x combination grid, 1 x universal pan

Optional accessories

Z11AB15A0	Baking tray, non-stick ceramic coated
Z11AU15A0	Universal pan, non-stick ceramic coated
Z11CR10X0	Baking and roasting grid (standard)
Z11GT10X3	Glass roasting dish, 5,4l
Z11TI15X0	Cliprails
Z13CR10X0	Baking and roasting grid (steam)



N 50, BUILT-UNDER DOUBLE OVEN J1ACE4HNOB

Features

- LCD Display (White)

Features

- Control panel lock
- Interior halogen light
- Cavity volume: 34 Litre
- Cavity (inner surface) top: Enamel grey
- EcoClean Direct: ceiling, back panel, side liners
- Door hinge small cavity: bottom
- 1 Clip rail, Stop function
- Cavity (inner surface) bottom: enamel anthracite
- EasyClean
- Full glass inner door
- Door hinge big cavity: Drop down door

Top oven additional features

- Oven with 4 heating methods: Top/bottom heat, Full surface grill, Small area grill, Bottom heat
- Temperature range 50 °C - 275 °C

Main oven additional features

- 2 x combination grid, 1 x universal pan

Performance/technical information

- Nominal voltage: 220 - 240 V
- Appliance dimension (hxxxd): 717 mm x 594 mm x 550 mm
- Please refer to the dimensions provided in the installation manual

N 50, BUILT-UNDER DOUBLE OVEN
J1ACE4HNOB

Dimensioned drawings

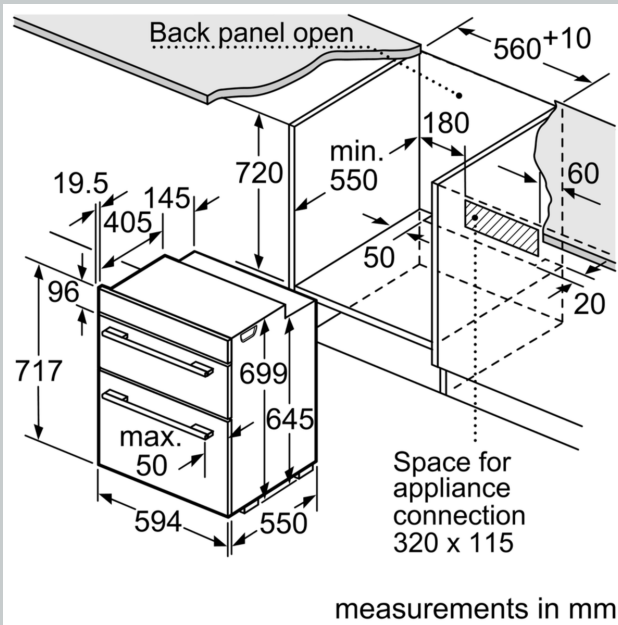

measurements in mm

If the appliance will be installed underneath a hob, the following worktop thicknesses (including substructure if necessary) must be taken into account.

Hob type	min. worktop thickness	
	fitted	flush
Induction hob	39	40
Full-surface induction hob	49	50
Gas hob	29	40
Electric hob	29	32

measurements in mm
Installation with a hob

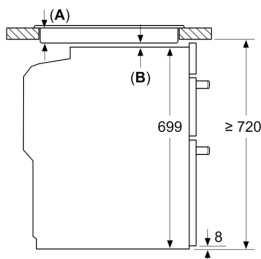

- A: Recessed depth 29-50 mm.
See hob dimensional drawing.
B: Min. distance:
Induction hob: 5 mm
Gas hob: 5 mm
Electric hob: 2 mm

measurements in mm

