

N 30, INDUCTION HOB, 60 CM, BLACK,  
T36FBE1LOG



Z1365WX0	Wireless food thermometer
Z9404SE0	4 pieces Set
Z9406SE0	6 pieces Set
Z9410ES0	Espresso maker 4 cups
Z9428FE0	Iron pan Ø 18 / 28 cm
Z943SE0	Set of 2 pots and 1 pan

Induction cooktop with TouchControl.

- √ Plug&Play: No electrician needed.
- √ Touch Control – Control your hob with just one touch and a timer.
- √ Power Boost – An extra surge of heat when you need fast results.
- √ Induction – the heat is generated directly in the cookware for precise cooking that stops when power is off.

Product name/family: ..... Cooking zone ceramic  
 Built-in / Free-standing: ..... Built-in  
 Energy input: ..... Electric  
 Number of cooking zones: ..... 4  
 Required niche size for installation (HxWxD): ..... 51 x 560-560 x 490-500 mm  
 Width of the appliance: ..... 592 mm  
 Dimensions: ..... 51x592x522 mm  
 Dimensions of the packed product (HxWxD): . 126 x 753 x 608 mm  
 Net weight: ..... 9.2 kg  
 Gross weight: ..... 11.4 kg  
 Residual heat indicator: ..... Separate  
 Location of control panel: ..... Front  
 Basic surface material: ..... Ceramic  
 Color of surface: ..... Black  
 Length electrical supply cord: ..... 110.0 cm  
 EAN code: ..... 4242004269403  
 Voltage: ..... 220-240 V  
 Frequency: ..... 50; 60 Hz



## N 30, INDUCTION HOB, 60 CM, BLACK, T36FBE1LOG

- 60 cm: space for 4 pots or pans.

### Flexibility of cooking zones

- Cooking zone front left: 180 mm, 1.8 KW (max. power 3.1 KW)
- Cooking zone rear left: 180 mm, 1.8 KW (max. power 3.1 KW)
- Cooking zone rear right: 145 mm, 1.4 KW (max power 2.2 KW)
- Cooking zone front right: 210 mm, 2.2 KW (max. power 3.7 KW)

### Usage convenience

- Touch control: control the power with imprinted +/- touch buttons.
- Variable 17-stage power settings for each zone: precisely adapt the heat with 17 power levels (9 main levels and 8 intermediate levels).
- Switch-off timer: switches off the cooking zone at the end of the time set (e.g. for boiled eggs).
- Count-down Timer: an alarm sounds at the end of the time set (e.g. for pasta).

### Time saving & efficiency

- Power Boost function for all zones
- : boil water faster thanks to 50% more energy than at the highest standard level.
- QuickStart function: when switching on, the hob automatically selects the cooking zone with cookware (when placed on a zone whilst the hob is off).
- ReStart function: in case of unintentional switch-off, this feature restores all previous settings by switching on the hob again within 4 seconds
- Quick-Off: quickly switch off a cooking zone with one longer touch.

### Design

- Bevelled front edge

### Safety

- 2 stage residual heat indicators: indicates which cooking zones are still hot or warm.
- Control panel lock: prevent unintended activation of the hob.
- Main switch: switch off all cooking zones at the touch of a button.
- Safety cut out facility: for safety reasons, heating stops after a preset time if not used.

### Installation

- Dimensions of the product (HxWxD mm): 51 x 592 x 522
- Required niche size for installation (HxWxD mm) : 51 x 560 x (490 - 500)
- Min. worktop thickness: 16 mm
- Connected load: 3.7 KW
- Power cord 1.1 m UK 3 pin plug: plug and play, no electrician required for installation.
- This hob is equipped with a UK 3 pin plug for an easy plug & play installation. The plug limits the maximum power output to 3.7 KW. For higher power output, please select a hob without plug and ensure installation is carried out by a qualified electrician.

N 30, INDUCTION HOB, 60 CM, BLACK,  
T36FBE1LOG

measurements in mm

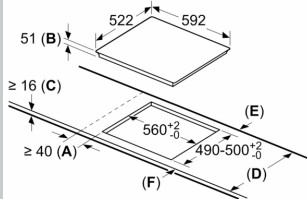

- A: Minimum distance from the hob cut-out to the wall.
- B: Recessed depth
- C: The clearance between the surface of the worktop and the top of the front of the oven must be 30 mm. See space requirements for the oven.

The worktop into which the hob is installed must withstand loads of approx. 60 kg; suitable substructures must be used if required.

D	E	F
585-600	50	≥ 35
> 600	≥ 50	≥ 50

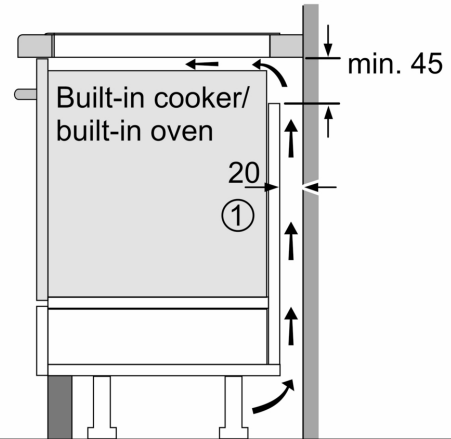

① Ventilation gap must be present

All measurements in mm

