

N 90, Built-in oven with added steam function, Stainless steel
B58VT68NOB



COOKING PASSION SINCE 1877



A

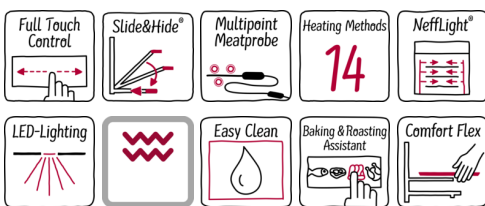

Built-in oven with VarioSteam and SLIDE&HIDE - fuller flavour and unrestricted access to the oven interior.

- ✓ Slide&Hide - the fully retracting oven door.
- ✓ VarioSteam - Steam assistance for CircoTherm ovens, that cooks food moist on the inside and crisp on the outside.
- ✓ The Multi Point roast thermometer helps the oven regulate the temperature and automatically adjust the cooking time.
- ✓ The perfect duo for cleaning: Pyrolysis after heavy use and EasyClean - the environment-saving option for fast oven cleaning.
- ✓ FullTouch Control - simple, precise oven control by fingertip touch on the smooth surface of the high resolution TFT colour display.
- ✓ NeffLight - perfect illumination of all four oven levels, even with the door shut.
- ✓ ComfortFlex - telescopic rails that come out far enough to let you grasp the baking sheet conveniently from the sides.

Features

Technical Data

Color / Material Front : Stainless steel
 Built-in / Free-standing : Built-in
 Integrated Cleaning system : Hydrolytic, Pyrolytic
 Required niche size for installation (HxWxD) : 585-595 x 560-568 x 550
 Dimensions of the product (mm) : 595 x 596 x 548
 Dimensions of the packed product (HxWxD) (mm) : 675 x 690 x 660
 Control Panel Material : Stainless steel
 Door Material : Glass
 Net weight (kg) : 40.306
 Usable volume of cavity (l) : 71
 Cooking method : , 4D hot air, Bottom heat, Bread Baking Setting, Conventional heat, Defrost, Full width grill, Half width grill, Hot Air-Eco, Hot air grilling, low temperature cooking, Pizza setting, pre-heating, warming
 First cavity material : Enamelled
 Temperature control : electronic
 Number of interior lights : 3
 Approval certificates : CE, VDE
 Length electrical supply cord (cm) : 120
 EAN code : 4242004182047
 Number of cavities (2010/30/EC) : 1
 Energy efficiency class (2010/30/EC) : A
 Energy consumption per cycle conventional (2010/30/EC) : 0.90
 Energy consumption per cycle forced air convection (2010/30/EC) : 0.74
 Energy efficiency index (2010/30/EC) : 87.1
 Connection Rating (W) : 3450
 Current (A) : 16
 Voltage (V) : 220-240
 Frequency (Hz) : 60; 50
 Plug type : no plug

Included accessories

2 x combination grid, 1 x universal pan

Optional accessories

Z11CR10X0 Baking and roasting grid (standard)
 Z11SZ80X0 SeamlessCombination 60 + 29cm
 Z11SZ90X0 SeamlessCombination 60 + 45cm
 Z11TC10X0 ComfortFlex Rail (1 level)
 Z12CB10A0 Baking tray, anthracite enamelled
 Z12CM10A0 Moussaka pan, anthracite enamelled
 Z12TF36X0 3 level telescopic rails, full ext,pyro
 Z19DD10X0 Steam set for ovens



4 242004 182047

*N 90, Built-in oven with added steam function,
Stainless steel
B58VT68NOB*

Features

Heating Functions

- Multi-function oven with 7 heating methods:
Bottom heat Grill - large area Hot Air grilling Pizza setting Top and Bottom heat HotAir 3D HotAir
- Additional heating methods with steam: Reheating, Dough Proving
- Temperature range 40 °C - 275 °C
- Cavity volume: 71 litres

Design

- Touch control
- Anthracite enamel cavity with 4 shelf positions

Cleaning

- Pyrolytic self cleaning
- EasyClean Cleaning program
- Full glass inner door - safer touch door

Convenience

- White LCD display
- Temperature proposal
Actual temperature display
Optical temperature control
AutoPilot
Sabbath setting
- Additional functions:
Descaling programme
Steam cooking function (system steamer accessory required)
Drying function
- SoftMove Door - SoftOpen & SoftClose
- Supporting systems: Bake and Roast assist, Automatic Programs
- Number of automatic programmes: 14 PC
- Multipoint MeatProbe
- Electronic clock
- Rapid heating-up
- Halogen Lighting
- Large 1 litre water tank
- Water tank empty indicator
- Location of the steam generator is outside of the cavity.
- Cooling fan
- Stainless-steel fan
- Info button
- Revolution handle
- Pull out system: Telescopic shelf rail. 1-level flexible, full extension, safety stop function

Accessories

- 2 x combination grid, 1 x universal pan

Cleaning

- Individual adjustable child lock
Residual heat indicator
Safety switch off

Technical Information

- Length of mains cable: 120 cm
- Total connected load electric: 3.45 KW
- Appliance dimension (hxwxh): 595 mm x 596 mm x 548 mm
- Installation dimensions (HxWxD): 585 mm - 595 mm x 560 mm - 568 mm x 550 mm
- Please reference the built-in dimensions provided in the installation drawing

N 90, Built-in oven with added steam function,
Stainless steel
B58VT68NOB

Dimensioned drawings

Installation with a hob.

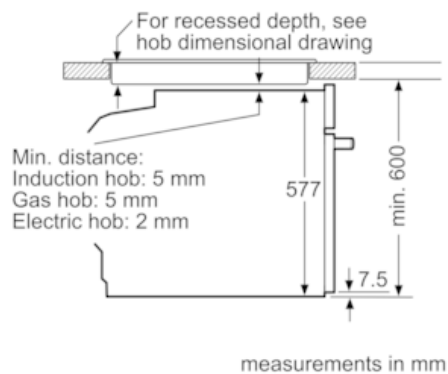

If the appliance will be installed underneath a hob, the following worktop thicknesses (including substructure if necessary) must be taken into account.

Hob type	min. worktop thickness	
	fitted	flush
Induction hob	37 mm	38 mm
Full surface Induction hob	47 mm	48 mm
Gas hob	30 mm	38 mm
Electric hob	27 mm	30 mm

