

N 90, Built-in compact oven with microwave function,
Stainless steel
C17MS32NOB



Compact built-in oven with integral microwave - even more ways to cook quickly and conveniently in a very small space.

- ✓ Compact oven with microwave - even more ways to cook quickly and conveniently.
- ✓ ShiftControl - fast navigation through menus and simple operation with the generous TFT display.
- ✓ EcoClean - the self-cleaning catalytic coating on the inside top and sides of the oven makes oven cleaning easier.
- ✓ BottomClean - the special cleaning programme for the oven floor.
- ✓ Modern LED lighting for bright, even illumination.
- ✓ Hinged door with cushioned opening and closing.

Features

Technical Data

Type of micro-wave oven : MW-Combi
 Type of control : Electronic
 Color / Material Front : Stainless steel
 Dimensions of the product (mm) : 455 x 596 x 548
 Cavity dimensions (mm) : 237.0 x 480 x 392.0
 Length electrical supply cord (cm) : 150
 Net weight (kg) : 35.633
 Gross weight (kg) : 38.0
 EAN code : 4242004182207
 Maximum micro-wave power (W) : 900
 Connection Rating (W) : 3600
 Current (A) : 16
 Voltage (V) : 220-240
 Frequency (Hz) : 50; 60
 Plug type : no plug

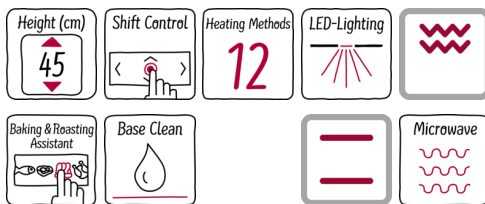

Optional accessories

Z11SZ60X0 SeamlessCombination 45 + 14cm
 Z11SZ90X0 SeamlessCombination 60 + 45cm
 Z12CB10A0 Baking tray, anthracite enamelled
 Z12CM10A0 Moussaka pan, anthracite enamelled
 Z14CR10X0 Baking and roasting grid (microwave)
 Z19DD10X0 Steam set for ovens



4 242004 182207

*N 90, Built-in compact oven with microwave
function, Stainless steel
C17MS32NOB*

Features

Heating Functions

- Compact oven with microwave with 12 heating methods:
 - 4D hot air
 - CircoTherm® Eco
 - Top/Bottom heating
 - Top/bottom heating Eco
 - Full surface grill
 - Small area grill
 - Pizza setting
 - Bottom heating
 - Slow cooking
 - Dough proving
 - Plate warming
- Additional heating methods with microwave: Microwave, Combi microwave variable
- Temperature range 30 °C - 300 °C
- Max. Power: 900 W; 5 Microwave power settings (90 W,180 W,360 W,600 W,900 W) with Inverter (MW)
- Cavity volume: 45 l

Design

- Illuminated ShiftControl
- Anthracite enamel cavity with 3 shelf positions

Cleaning

- EcoClean Direct : ceiling, side liners, back panel
- EcoClean program, EasyClean program
- Microwave top door

Convenience

- 4.1" TFT colour and graphics display with ShiftControl
- Temperature proposal
 - Actual temperature display
 - Optical temperature control
 - Automatic Programming
 - Sabbath setting
- Additional functions:
 - Steam cooking function (system steamer accessory required)
- Drop down door, SoftMove oven door with soft open and soft close, SoftOpen
- Supporting systems: Bake and Roast assist, Automatic Programs
- Number of automatic programmes: 14 PC
- Electronic clock
- Rapid heating-up
- LED light
- Cooling fan
- Stainless-steel fan
- Info button
- Bar handle

Hook-in racks / rails

- Cavity with shelf support rails, Telescopic slide-out Not available

Accessories

- 1 x combination grid, 1 x universal pan

Safety and Environment

- Individual adjustable child lock
 - Residual heat indicator
 - Safety switch off

Technical Information

- Length of mains cable: 150 cm
- Total connected load electric: 3.6 KW
- Appliance dimension (hxwxh): 455 mm x 596 mm x 548 mm
- Installation dimensions (HxWxD): 450 mm - 455 mm x 560 mm - 568 mm x 550 mm
- Please reference the built-in dimensions provided in the installation drawing

N 90, Built-in compact oven with microwave function, Stainless steel
C17MS32NOB

Dimensioned drawings

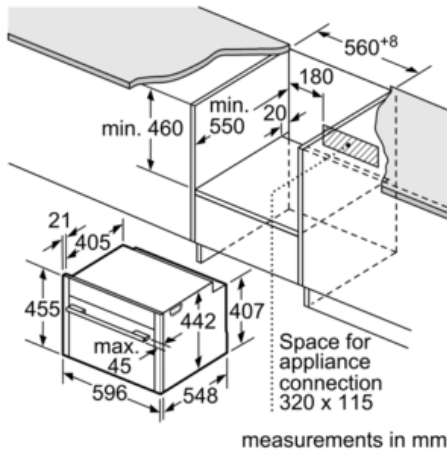

If the compact appliance will be installed underneath a hob, the following worktop thicknesses (including substructure if necessary) must be taken into account.

Hob type	min. worktop thickness	
	fitted	flush
Induction hob	42 mm	43 mm
Full surface Induction hob	52 mm	53 mm
Gas hob	32 mm	43 mm
Electric hob	32 mm	35 mm

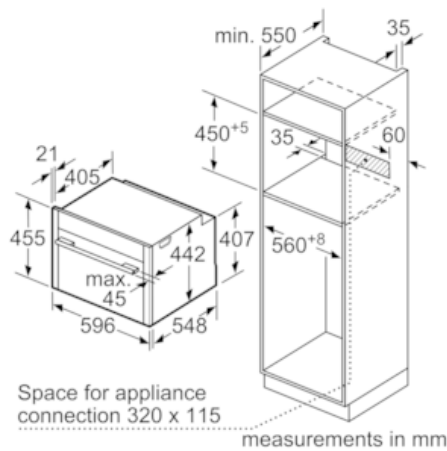

Installation with a hob.

