

IZVLEČNA VODILA, 1-NIVOJA + SPONKA  
Z11TJ25X0

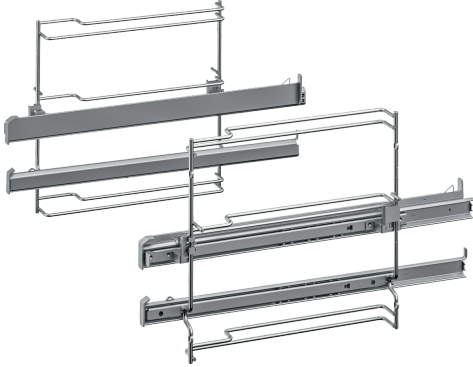

Oprema

Tehnični podatki

Mere embalaranega izdelka: .....85 x 305 x 410 mm  
Dimenzija palete: ..... 77.0 x 80.0 x 120.0  
Standardno število enot na paleto: .....48  
Neto masa: ..... 1.6 kg  
Bruto masa: ..... 1.9 kg  
EAN koda: .....4242004225522

